

DREDGING NOTE:
TAPER TO PROVIDE
DEPTH OF -3.5 FEET
CHANNELWARD OF
DOCK WHERE POSSIBLE
AT ALL LOCATIONS.

PROPOSED RIPRAP FILL AREAS IN WATERS OF THE U.S.
ABOVE MEAN HIGH WATER = 1,775 S.F.±
MEAN HIGH WATER TO MEAN LOW WATER = 1,213 S.F.±
CHANNELWARD OF MEAN LOW WATER = 227 S.F.±

DREDGE QUANTITIES
AREA OF PROPOSED DREDGING = 8,064 S.F.±
VOLUME OF PROPOSED DREDGING = 263 C.Y.±

LEGEND

	EXISTING	PROPOSED
PROPERTY LINE	---	---
BOUNDARY OF WATERS OF THE U.S.	---	---
MEAN HIGH WATER	---	---
MEAN LOW WATER	---	---
FEDERAL CHANNEL	---	---
SALTMARSH GRASS	---	---
SPOT ELEVATION	x 2.72	---
CONTOUR	---	---
FENCE	x	x
TREE	---	---
DOCK / PIER	---	---
GRAVEL ACCESS DRIVE	---	---
PATH	---	---
RIPRAP BANK	---	---
LIMITS OF DREDGING	---	---
STORM DRAIN PIPE	---	---

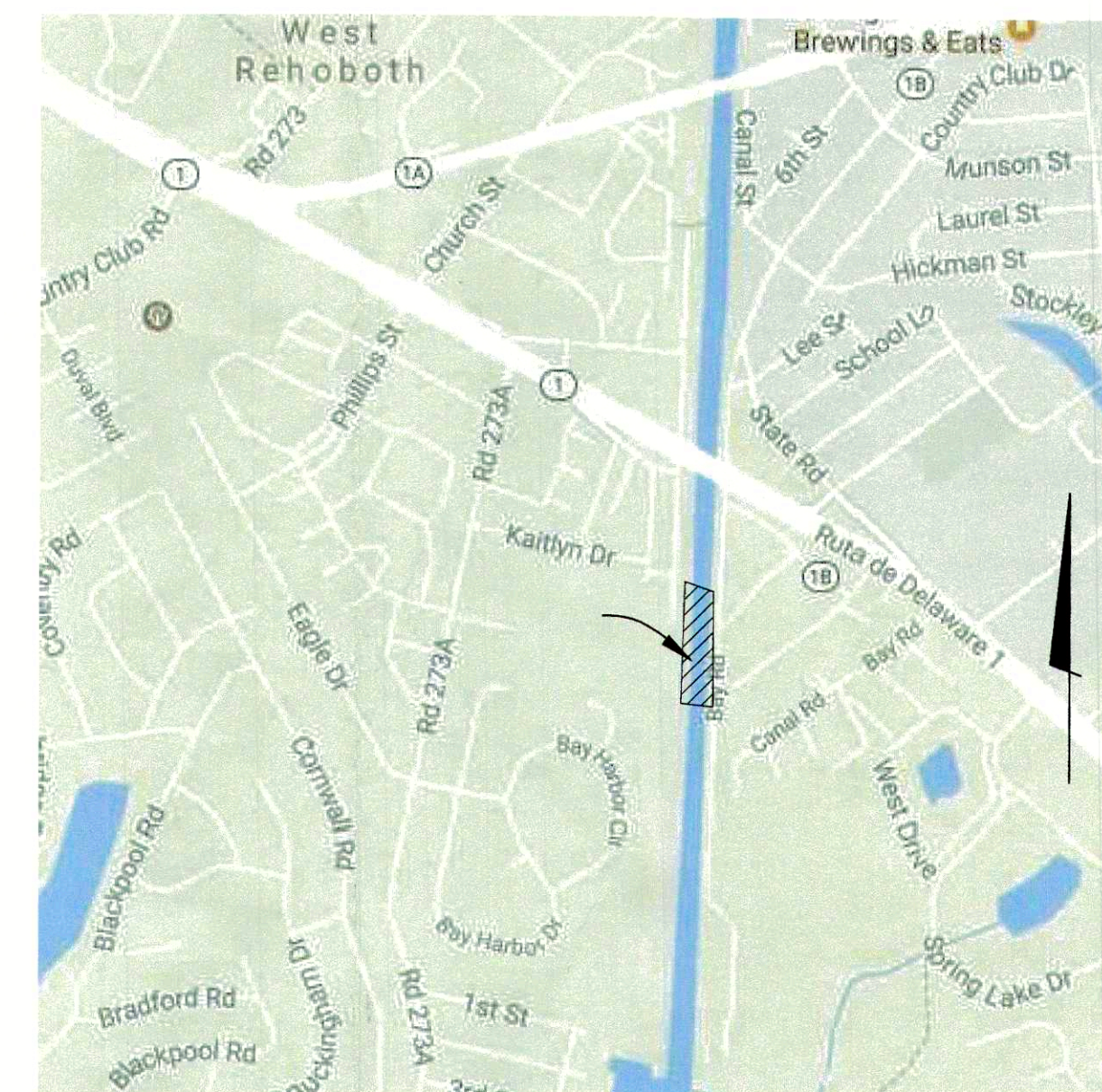

solutions
Integrated Planning
Engineering & Management, LLC

303 North Bedford Street
Georgetown, DE 19847
T. 302.297.9218
3003 Merritt Mill Road
Solisbury, MD 21804
T. 410.572.8833
www.solutionsipem.com Copyright © 2017

Seal
Date

NO.	DATE	DESCRIPTION

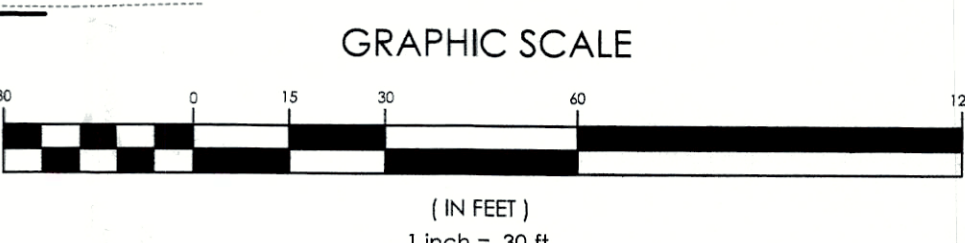
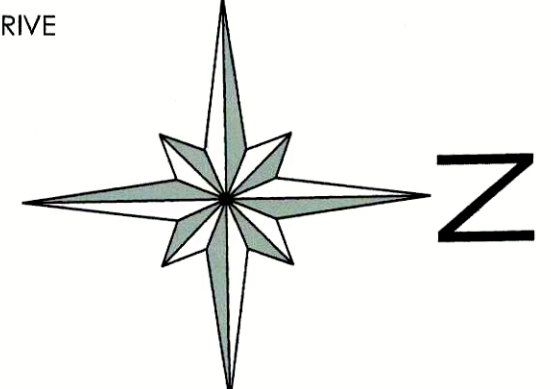
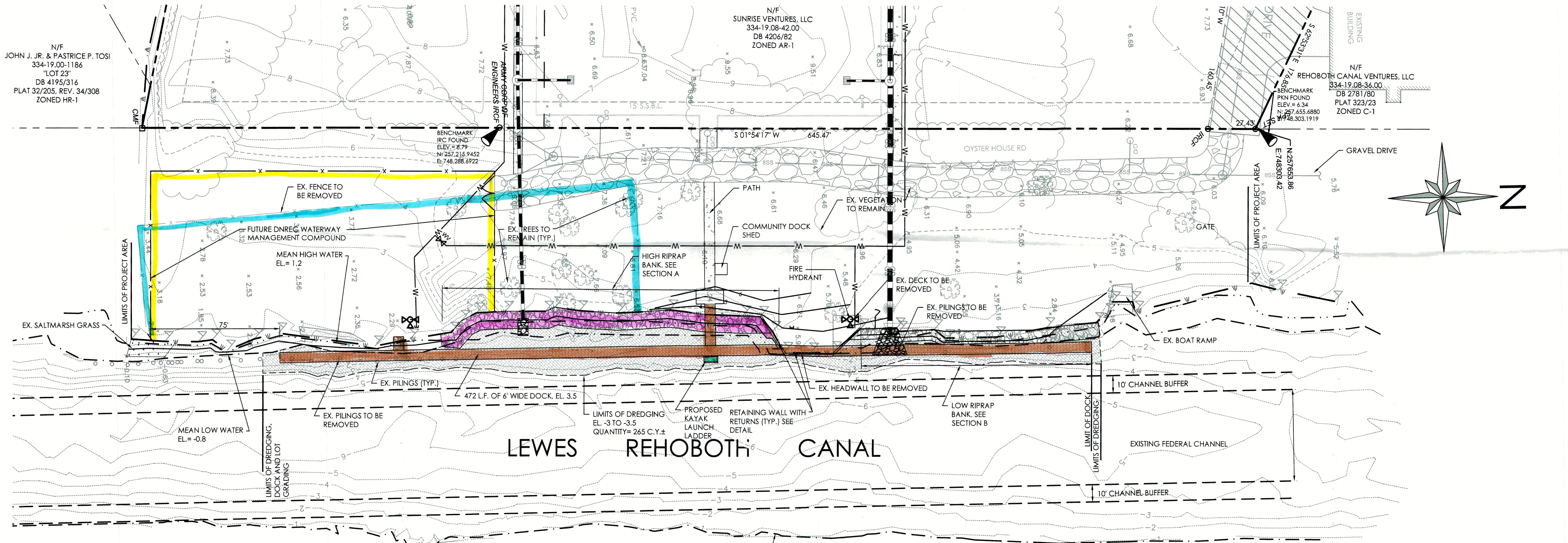

PROPOSED OYSTER HOUSE VILLAGE COMMUNITY DOCK
ON THE LANDS OF
UNITED STATES OF AMERICA
LEWES REHOBOTH CANAL
INDIAN RIVER HUNDRED
SUSSEX COUNTY, DELAWARE

Date:	2/5/19
Job Number:	G15049
Scale:	1"=30'
Drawn By:	ML
Designed By:	HHB
Approved By:	JP

Sheet No.: **1**
File Name: 15049-pier-dock

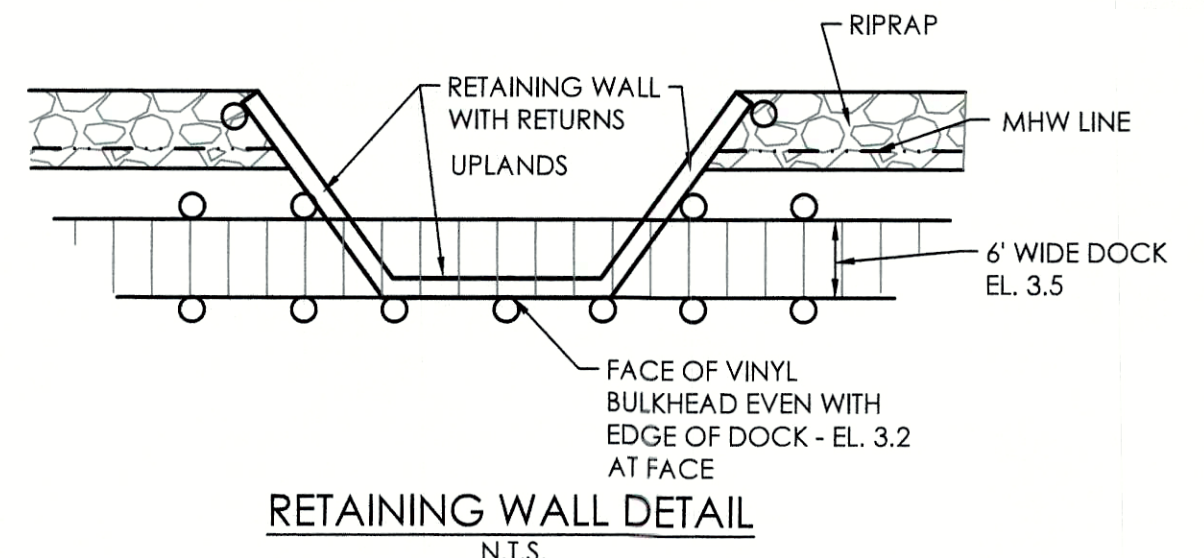
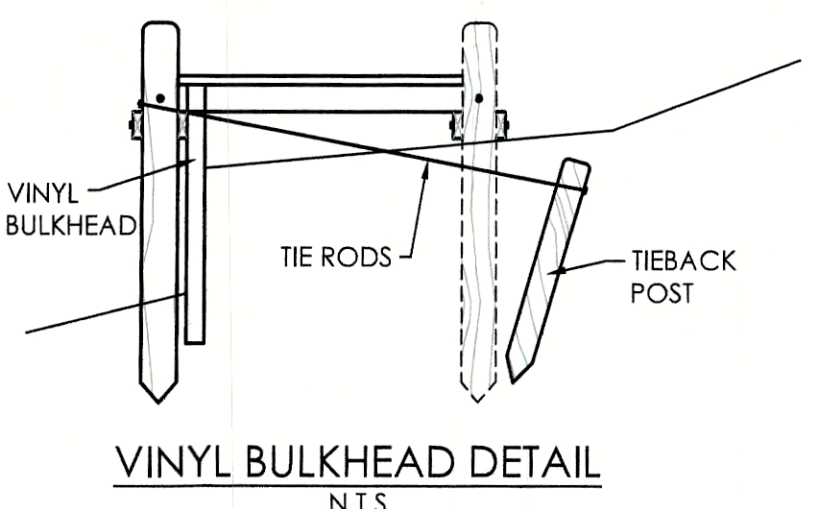
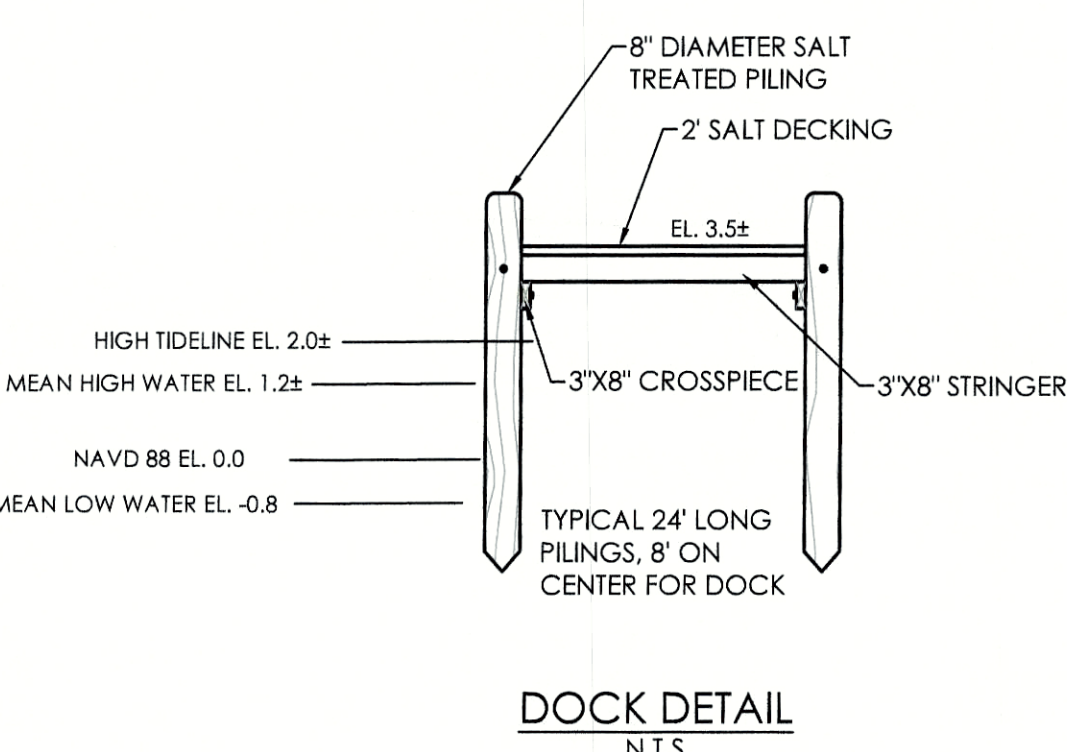

SITE DATA

- OWNER: UNITED STATES OF AMERICA
P.O. BOX 2000
GEORGETOWN, DE
- TAX REFERENCE: 334-19.00-173.00
- PROPERTY IS ZONED AR-1
- PROPERTY IS LOCATED IN FLOOD ZONE AE (EL. 5); SPECIAL FLOOD HAZARD AREAS SUBJECT TO INUNDATION BY THE 1% ANNUAL CHANCE FLOOD, PER FIRM MAP NUMBER 1000SC0354K, MAP REVISED MARCH 16, 2015.
- NO TITLE SEARCH WAS REQUESTED OR STIPULATED.
- OTHER THAN SHOWN, THIS SURVEY DOES NOT VERIFY THE EXISTENCE OR NONEXISTENCE OF RIGHTS-OF-WAY OR EASEMENTS.

I, EDWARD M. LAUNAY, PWS, STATE THAT THE BOUNDARIES OF WATERS OF THE UNITED STATES INCLUDING WETLANDS SUBJECT TO THE CORPS OF ENGINEERS REGULATORY PROGRAM DELINEATED UPON THIS PLAN HAVE BEEN DETERMINED USING MY PROFESSIONAL JUDGEMENT IN ACCORDANCE WITH THE 1987 CORPS OF ENGINEERS WETLAND DELINEATION MANUAL, REGULATIONS AND SUPPLEMENT GUIDANCE [33CFR 328.3(a)(8), Water of the U.S. Definition/CECW-OR 10-7-1991, Questions and Answers on the 1987 COE Manual/CECW-OR, 9-26-1990, RGL 90-7/CECW-OR, 3-6-1992, Clarification and Interpretations of the 1987 Manual]. THIS DELINEATION HAS NOT BEEN CONDUCTED FOR USDA PROGRAM OR AGRICULTURAL PURPOSES.

IN ACCORDANCE WITH DNREC TIDAL WETLAND MAP NO. SUSSEX 035 THERE ARE NO STATE REGULATED WETLANDS ON THIS SITE.

EDWARD M. LAUNAY, PWS NO. 875
SOCIETY OF WETLAND SCIENTISTS
(CORPS OF ENGINEERS,
CERTIFIED WETLAND DELINEATOR WDCP93MD05100368)

I, BARRY M. HALL, HEREBY STATE THAT I AM A PROFESSIONAL LAND SURVEYOR IN THE STATE OF DELAWARE AND THAT, TO THE BEST OF MY KNOWLEDGE, INFORMATION AND BELIEF, THE WETLAND BOUNDARY SHOWN AND DESCRIBED HEREON IS TRUE AND CORRECT TO THE ACCURACY REQUIRED BY ACCEPTED SURVEYING STANDARDS FOR A SUBURBAN CLASS SURVEY.

SOLUTIONS INTEGRATED PLANNING & MANAGEMENT, LLC.
by BARRY M. HALL, AGENT

BARRY M. HALL
PROFESSIONAL LAND SURVEYOR DE NO. 618