

DRAWING INDEX

SHEET	TITLE
1	COVER SHEET
2	EROSION & SEDIMENT CONTROL GENERAL NOTES
3-5	EROSION & SEDIMENT CONTROL DETAILS
6	TRAFFIC CONTROL DETAILS
7	CAMDEN CONTROLLER FACILITY SITE LAYOUT & PLAN
8	CAMDEN CONTROLLER FACILITY SECTION VIEWS
9	CAMDEN CONTROLLER EASTERN TIE-IN PLAN
10	CAMDEN CONTROLLER FACILITY HAZARDOUS CLASSIFICATION & GROUNDING PLAN
11 - 14	CONSTRUCTION DETAILS
15	CAMDEN CONTROLLER PIPING AND INSTRUMENTATION DETAILS
16 - 17	PI&ID SYMBOLS AND LEGENDS
18	CAMDEN CONTROLLER PLAN & PROFILE

EASTERN SHORE NATURAL GAS COMPANY CAMDEN CONTROLLER

PROPOSED 0.2± MILES OF 6" NATURAL GAS PIPELINE
KENT COUNTY, DELAWARE
PROJECT NUMBER: ES XXXX
MOC: 2025-XX

Received by DNREC DCMP 6/26/2026.

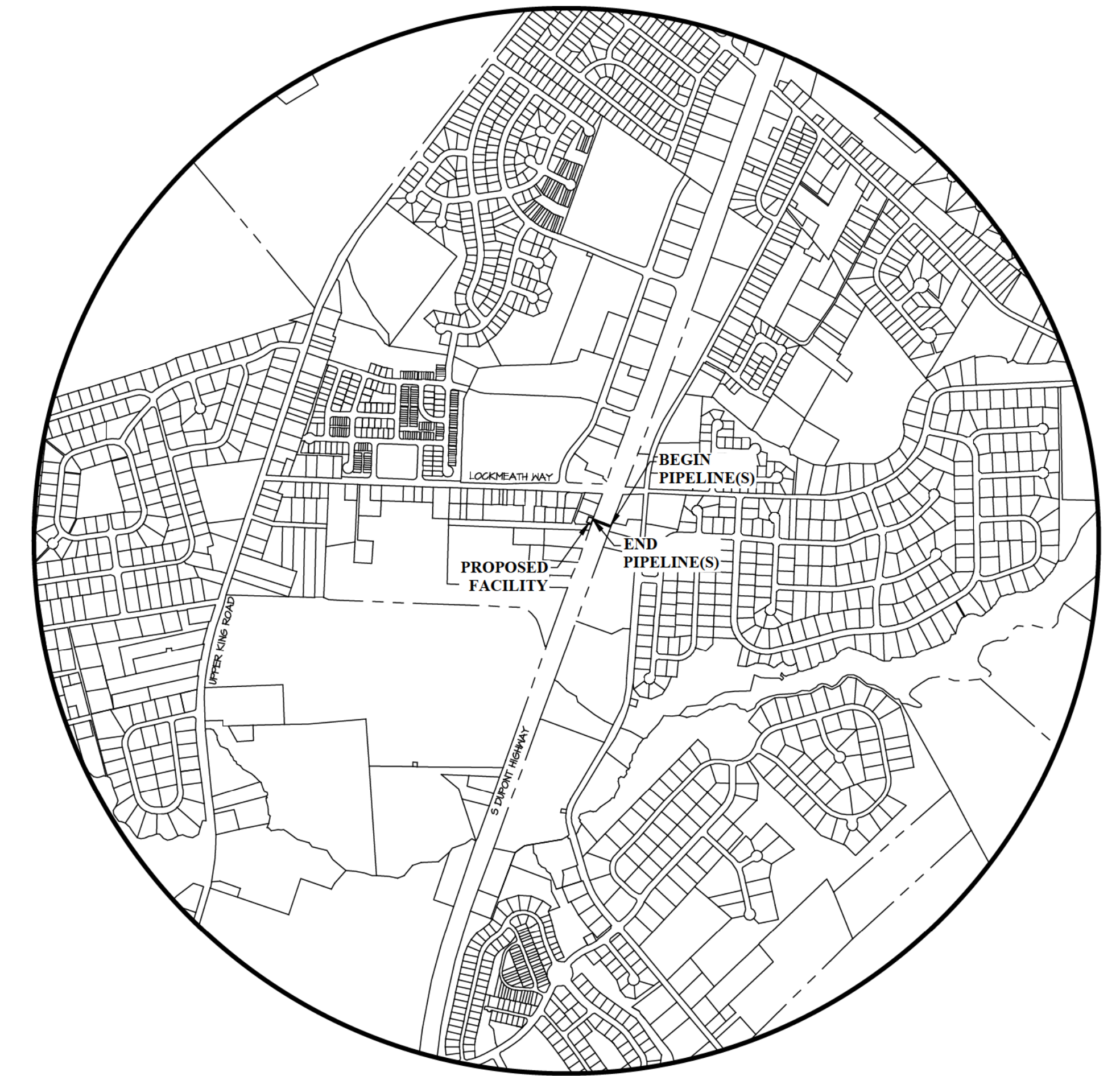
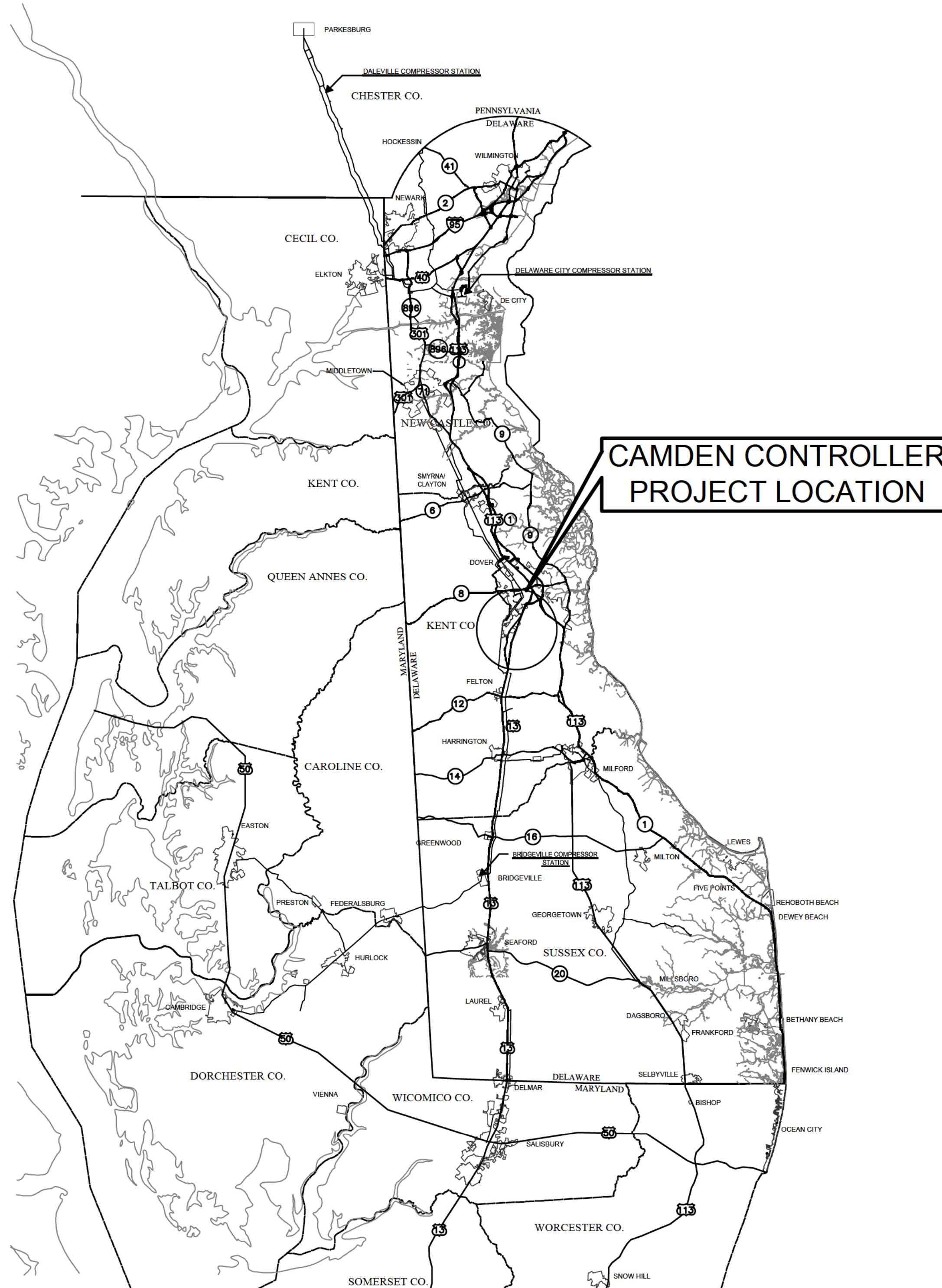

CAMDEN CONTROLLER
PROJECT LOCATION

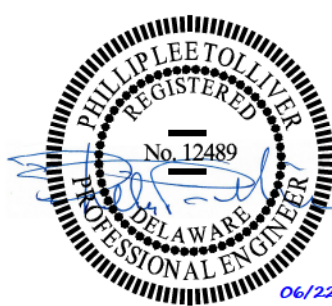
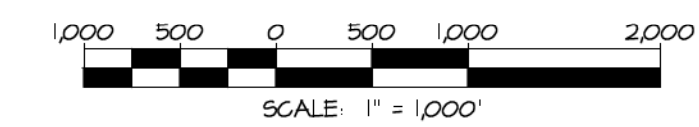

REVISIONS			
NO.	DATE	DESCRIPTION	BY

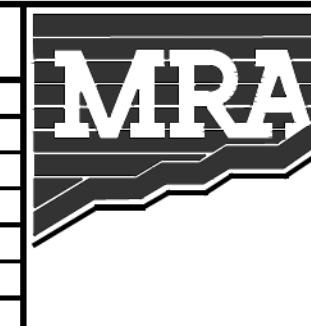

MORRIS & RITCHIE ASSOCIATES, INC.
ENGINEERS, PLANNERS, SURVEYORS AND
LANDSCAPE ARCHITECTS
111 RUTHAR DRIVE
NEWARK, DE 19711
(302) 326-2200
MRA@TA.COM
© 2026 MORRIS & RITCHIE ASSOCIATES, INC.



COVER SHEET			
6" PROPOSED PIPELINE CAMDEN CONTROLLER KENT COUNTY, DE			
ESNG PROJECT CODE:	23098	DATE:	6/19/2026
MRA PROJECT NO:	23098	SCALE:	AS SHOWN
DESIGN/CHECK BY:	JTH/CWB	SHEET:	1 OF 18

GENERAL ENVIRONMENTAL NOTES

- EROSION/SEDIMENTATION CONTROL STRUCTURES TO BE INSTALLED AND MAINTAINED AS NECESSARY DURING CONSTRUCTION TO AVOID/MINIMIZE IMPACT TO WETLANDS AND WATERBODIES. THESE BARRIERS WILL REMAIN IN PLACE UNTIL REVEGETATION AND RESTORATION ARE DEEMED SUCCESSFUL.
- ANY TRENCH DENATURING TO BE DIRECTED TO SEDIMENT FILTER BAG AND/OR DENATURING STRUCTURE IN AN UPLAND AREA TO ENSURE THAT NO EROSION OR SEDIMENTATION OCCURS TO WETLANDS/WATERBODIES.
- PRE-CONSTRUCTION CONTOURS TO BE RE-ESTABLISHED FOR ALL DISTURBED AREAS UNLESS OTHERWISE NOTED ON THE PLANS. ALL DISTURBED AREAS TO BE RESTORED AND/OR REVEGETATED AS APPLICABLE.
- ALL DISTURBED AREAS TO BE RESTORED AND/OR REVEGETATED AS APPLICABLE. SEED, FERTILIZER, LIME AND MULCH TO BE APPLIED IN ACCORDANCE WITH RECOMMENDATIONS FROM LOCAL NATURAL RESOURCES CONSERVATION SERVICE (NRCS), AND LANDOWNER REQUIREMENTS (AGRICULTURAL AREAS). SEE SHEET 4 OF 18 FOR MULCH APPLICATION REQUIREMENTS.
- FOR NON-ROADWAY AREAS, UPLAND RE-SEEDING TO BE PERFORMED IN ACCORDANCE WITH THE VEGETATIVE STABILIZATION DETAILS (SEE SHEET 5 OF 18).
- CONSTRUCTION TO BE PERFORMED IN ACCORDANCE WITH REQUIREMENTS IN FERC UPLAND EROSION CONTROL, REVEGETATION AND MAINTENANCE PLAN AND FERC WETLAND AND WATERBODY CONSTRUCTION AND MITIGATION PROCEDURES.
- THE KENT CONSERVATION DISTRICT SEDIMENT AND STORMWATER MANAGEMENT PROGRAM MUST BE NOTIFIED IN WRITING FIVE (5) DAYS PRIOR TO COMMENCEMENT OF CONSTRUCTION. FAILURE TO DO SO CONSTITUTES A VIOLATION OF THE APPROVED SEDIMENT AND STORMWATER MANAGEMENT PLAN.
- REVIEW AND/OR APPROVAL OF THE SEDIMENT AND STORMWATER MANAGEMENT PLAN SHALL NOT RELIEVE THE CONTRACTOR FROM HIS OR HER RESPONSIBILITIES FOR COMPLIANCE WITH THE REQUIREMENTS OF THE SEDIMENT AND STORMWATER REGULATIONS, NOR SHALL IT RELIEVE THE CONTRACTOR FROM ERRORS OR OMISSIONS IN THE APPROVED PLAN.
- IF THE APPROVED PLAN NEEDS TO BE MODIFIED, ADDITIONAL SEDIMENT AND STORMWATER CONTROL MEASURES MAY BE REQUIRED AS DEEMED NECESSARY BY THE KENT CONSERVATION DISTRICT.
- FOLLOWING SOIL DISTURBANCE OR REDISTURBANCE, PERMANENT OR TEMPORARY STABILIZATION SHALL BE COMPLETED WITHIN 14 CALENDAR DAYS AS TO THE SURFACE OF ALL PERIMETER SEDIMENT CONTROLS, SOIL STOCKPILES, AND ALL OTHER DISTURBED OR GRADED AREAS ON THE PROJECT SITE.
- IT WILL BE THE RESPONSIBILITY OF THE CONTRACTOR TO MAINTAIN AND REPAIR ALL EROSION AND SEDIMENT CONTROL AND STORMWATER MANAGEMENT PRACTICES DURING CONSTRUCTION. THIS WILL BE MONITORED BY THE EASTERN SHORE NATURAL GAS (ESNG) ENVIRONMENTAL INSPECTOR. FOLLOWING CONSTRUCTION, ESNG WILL CONTINUE TO MONITOR THE EROSION AND SEDIMENT CONTROL AND STORMWATER MANAGEMENT MEASURES, UNTIL REVEGETATION AND RESTORATION ARE DEEMED SUCCESSFUL. DURING THIS TIMEFRAME, ESNG WILL ARRANGE FOR ANY NECESSARY REPAIRS AND MAINTENANCE TO SUCH STRUCTURES AND MEASURES. ESNG WILL ALSO ARRANGE FOR ANY AND ALL NECESSARY ADDITIONAL REVEGETATION AND/OR RESTORATION MEASURES DURING THIS TIMEFRAME.
- REFER TO TYPICAL TOPSOIL SEGREGATION DETAIL FOR SUBSOIL/TOPSOIL FILE INFORMATION ON SHEET 5 OF 18.
- ALL STONE, WITH THE EXCEPTION OF CHECK DAMS, MUST BE UNDERLAIN WITH A GEOTEXTILE FABRIC (E.G., TEMPORARY CONSTRUCTION ENTRANCES OFF PUBLIC ROADWAYS). GEOTEXTILE FABRIC SPECIFICATIONS WILL BE PROVIDED FOR VARIOUS APPLICATIONS.
- EROSION CONTROL MATTING IS REQUIRED FOR RESTORATION ON SLOPES OF 3:1 OR GREATER.
- CONTRACTOR SHALL USE STREET SWEEPER AS REQUIRED TO MINIMIZE DUST AND SOIL ON ROADWAYS. IF DUST IN NON-ROADWAY AREAS BECOMES A PROBLEM, CONTRACTOR TO APPLY WATER TO CONSTRUCTION RIGHT-OF-WAY TO PROVIDE DUST CONTROL.
- TEMPORARY CONSTRUCTION ENTRANCES (ROCK AND GEOTEXTILE FABRIC) TO BE INSTALLED FOR ACCESS FROM PUBLIC ROADS TO TEMPORARY CONSTRUCTION WORK AREAS ADJACENT TO PUBLIC ROADS (SEE TEMPORARY CONSTRUCTION ENTRANCE DETAIL). CULVERT PIPES TO BE INSTALLED WHERE NECESSARY FOR ACCESS ACROSS DITCHES OR SHALES, TO MAINTAIN EXISTING DRAINAGE PATTERNS.
- UNLESS NOTED IN THE CONSTRUCTION LINE LIST, TOPSOIL SHALL BE STRIPPED AND SEGREGATED PRIOR TO TRENCHING IN AGRICULTURAL AREAS (MAX. DEPTH 12 INCHES). AFTER COMPLETION OF SUBSOIL BACKFILL, TOPSOIL TO BE RETURNED TO REQUIRED AREAS AND GRADED. TOPSOIL SHALL ALSO BE SEGREGATED IN ALL TEMPORARY CONSTRUCTION WORKSPACE AREAS IN AGRICULTURAL AREAS. TOPSOIL SHALL ALSO BE SEGREGATED IN ALL AREAS WHERE THE PROPOSED PIPELINE IS INSTALLED IN UNPAVED ROAD RIGHT OF WAY AREAS. IF TOPSOIL IS NOT SEGREGATED IN THESE AREAS, THEN CONTRACTOR SHALL BE RESPONSIBLE FOR INSTALLING NEW TOPSOIL TO ACTUAL DEPTH OF EXISTING TOPSOIL (MIN. 6" DEPTH/MAX. 12" DEPTH).

STABILIZATION NOTES

- FOR ROADWAY AREAS REFER TO DELDOT NOTES ON SHEET 6 OF 18.
- FOR NON-ROADWAY AREAS, REFER TO NOTES AND DETAILS ON RESTORATION SEEDING AND MULCHING. RESTORATION IN NON-ROADWAY AREAS (UPLANDS AND WETLANDS) WILL BE PERFORMED WITHIN 7 DAYS OF BACKFILL. IN STREAM AREAS, RESTORATION WILL BE PERFORMED WITHIN ONE TO TWO DAYS OF PIPELINE INSTALLATION AND BACKFILL. ALL DISTURBED SOIL SHALL BE STABILIZED AS THE CONTRACTOR PROGRESSES WITHIN 5 WORKING DAYS OF DISTURBANCE.

CONSTRUCTION NOTES AND SEQUENCING

NOTIFICATION:
THE KENT CONSERVATION DISTRICT SEDIMENT AND STORMWATER MANAGEMENT PROGRAM MUST BE NOTIFIED IN WRITING FIVE (5) DAYS PRIOR TO COMMENCEMENT OF CONSTRUCTION. FAILURE TO DO SO CONSTITUTES A VIOLATION OF THE APPROVED SEDIMENT AND STORMWATER MANAGEMENT PLAN. PRIOR TO ANY CLEARING, INSTALLATION OF SEDIMENT CONTROL MEASURES OR GRADING, A PRE-CONSTRUCTION MEETING MUST BE SCHEDULED AND CONDUCTED WITH THE AGENCY CONSTRUCTION SITE REVIEWER. THE LANDOWNER/DEVELOPER, CONTRACTOR, AND CERTIFIED CONSTRUCTION REVIEWER ARE REQUIRED TO BE IN ATTENDANCE AT THE PRE-CONSTRUCTION MEETING; THE DESIGNER IS RECOMMENDED TO ATTEND.

WORK AREAS:
CONSTRUCTION WORK AREAS TO BE CONFINED TO THE LIMITS SHOWN ON THE DRAWINGS. CONTRACTOR SHALL USE MATTING WHEN WORKING OVER EXISTING EASTERN SHORE FACILITIES AT NO ADDITIONAL COST TO EASTERN SHORE. CONTRACTOR SHALL TEST HOLE AND VERIFY EXISTING PIPELINE DEPTH PRIOR TO WORKING OVER EXISTING FACILITIES. CONTRACTOR SHALL PROVIDE BEARING CALCULATIONS TO DETERMINE NEED FOR MATTING OR LOW PRESSURE GROUND TRACKING EQUIPMENT AND CONFIRM WITH EASTERN SHORE THE METHODOLOGY PRIOR TO WORKING IN THAT AREA. ANY DAMAGE TO EXISTING EASTERN SHORE FACILITIES WILL BE REPAIRED AND/OR REPLACED AT THE CONTRACTORS EXPENSE.

MATERIALS:
ALL PIPELINE COATING MATERIAL SHALL BE PROVIDED, STORED AND APPLIED BY CONTRACTOR PER ESNG CONSTRUCTION STANDARDS MANUAL AND APPROVED MATERIAL LIST.

EROSION AND SEDIMENTATION CONTROLS:
ALL PERIMETER CONTROLS ARE TO BE REVIEWED BY THE AGENCY CONSTRUCTION SITE REVIEWER AND APPROVED PRIOR TO PROCEEDING WITH FURTHER SITE DISTURBANCE OR CONSTRUCTION. THE CONTRACTOR SHALL AT ALL TIMES PROTECT AGAINST SEDIMENT OR DEBRIS LADEN RUNOFF OR WIND FROM LEAVING THE SITE. PERIMETER CONTROLS SHOULD BE CHECKED DAILY AND ADJUSTED AND/OR REPAIRED TO FULLY CONTAIN AND CONTROL SEDIMENTATION ON THE SITE. ACCUMULATED SEDIMENT SHALL BE REMOVED WHEN IT HAS REACHED HALF OF THE EFFECTIVE CAPACITY OF THE CONTROL. IN ADDITION, THE CONTRACTOR MAY NEED TO ADJUST OR REPAIR MEASURES IN TIMES OF ADVERSE WEATHER CONDITIONS OR AS DIRECTED BY THE AGENCY CONSTRUCTION SITE REVIEWER. EROSION AND SEDIMENTATION CONTROL BARRIERS (SILT FENCE) WILL BE INSTALLED AND MAINTAINED PRIOR TO EARTH DISTURBANCE TO AVOID/MINIMIZE IMPACT TO WETLANDS AND WATERBODIES. EROSION/SEDIMENT CONTROL BARRIERS ARE SHOWN ON THE DRAWINGS. ACTUAL SILT FENCE LOCATIONS SHALL BE FIELD DETERMINED BASED ON SITE CONDITIONS, AND SHALL BE AGREED TO/APPROVED BY ESNG CONSTRUCTION INSPECTION REPRESENTATIVES. THESE BARRIERS WILL REMAIN IN PLACE UNTIL REVEGETATION AND RESTORATION ARE DEEMED SUCCESSFUL (SEE GENERAL ENVIRONMENTAL NOTES THIS SHEET). EROSION AND SEDIMENT CONTROL DEVICES SHOULD BE REMOVED ONLY AFTER WORK IN AN AREA HAS BEEN COMPLETED AND STABILIZED, WITH WRITTEN APPROVAL FROM THE AGENCY CONSTRUCTION SITE REVIEWER.

CLEARING OF VEGETATION:
TREE CLEARING WILL BE LIMITED TO THE MINIMUM NEEDED TO CONSTRUCT THE PIPELINE. ALL WOODED AREAS CLEARED FOR TEMPORARY WORK SPACE WILL BE ALLOWED TO NATURALLY REGENERATE.

PIPELINE INSTALLATIONS BENEATH ROADWAY CULVERTS:
THE HDD CROSSINGS ARE PROPOSED TO BE PERFORMED WITHIN THE ROAD ROW OR PERMANENT EASEMENT AND WILL BE DESIGNED TO MEET ALL REQUIREMENTS AND SPECIFICATIONS OF DELAWARE DEPARTMENT OF TRANSPORTATION (DELDOT). THE DESIGNS WILL BE PERFORMED TO ENSURE THE COMPLETE STRUCTURAL INTEGRITY OF THE ROADWAY AND ADJACENT AREAS, WHILE ALSO MAINTAINING SUFFICIENT CLEARANCE UNDER UTILITIES, CULVERT STRUCTURES AND FOOTINGS. EROSION/SEDIMENT CONTROLS WILL BE INSTALLED AND MAINTAINED THROUGHOUT CONSTRUCTION TO ENSURE THAT NO SEDIMENTATION OCCURS TO WETLANDS OR WATERBODIES OUTSIDE THE ROADWAY. UPON COMPLETION OF CONSTRUCTION, ALL PITS AND OTHER AREAS WILL BE BACKFILLED AND COMPACTED TO ENSURE THE INTEGRITY OF THE STRUCTURES AND ROADWAY.

TRENCH EXCAVATION AND BACKFILLING:
THE TRENCH REQUIRED FOR THE PIPELINE INSTALLATION WILL BE EXCAVATED TO ENSURE THE REQUIRED DEPTH OF COVER. IN GENERAL, A MINIMUM OF 4 FEET OF COVER WILL BE PLACED OVER THE PIPELINE, BACKFILLING WITH COMPACTED MATERIAL MEETING THE REQUIREMENTS OF DELDOT. IN PAVED AREAS TRENCHLINE IS TO BE SANKUT, AND PAVEMENT WILL BE DISPOSED OF AT AN APPROVED FACILITY. UPON COMPLETION OF THE PIPELINE INSTALLATION ACTIVITIES, THE GROUND SURFACE WILL BE GRADED TO CONSTRUCTION CONDITIONS. TRENCH WATER OR OTHER FORMS OF TURBID WATER WILL NOT BE DIRECTLY DISCHARGED ONTO EXPOSED SOIL SURFACES OR INTO ANY WETLAND OR STREAMS. GROUNDWATER SEEPAGE WILL BE PUMPED OUT OF THE TRENCH AND DIRECTED TO A PRE-MANUFACTURED FILTER BAG (OR EQUIVALENT) SIZED FOR THE EXPECTED VOLUME OF EFFLUENT, WHICH WILL BE PLACED IN AN UPLAND AREA SURROUNDED BY A HAY BALE ENCLOSURE IF NECESSARY. SILT AND SEDIMENT WILL COLLECT IN THE FILTER BAG WHILE ALLOWING NON-TURBID WATER TO LEACH OUT AND INFILTRATE INTO THE GROUND. THE COLLECTED SILT, SEDIMENT, AND USED FILTER BAG WILL BE PROPERLY DISPOSED OFF-SITE.

HORIZONTAL DIRECTIONAL DRILLING:
CONTRACTOR SHALL UTILIZE A BENDING MACHINE PER COMPANY STANDARDS TO ACHIEVE PROPER COVER AND BREAK-OVER AT HORIZONTAL DIRECTIONAL DRILL ENTRY AND EXIT LOCATIONS. ADDITIONAL FITTINGS SHALL BE UTILIZED AT CONTRACTOR'S EXPENSE.

HYDROSTATIC TESTING OF THE PROPOSED PIPELINE:
IN COMPLIANCE WITH U.S. DEPARTMENT OF TRANSPORTATION PIPELINE SAFETY AND INTEGRITY REGULATIONS, EASTERN SHORE NATURAL GAS WILL HYDROSTATICALLY TEST THE PROPOSED NATURAL GAS PIPELINE PRIOR TO PLACING THE PROPOSED PIPELINE IN SERVICE. THE SOURCE OF WATER FOR THE HYDROSTATIC TEST WILL BE DETERMINED BEFORE THE TEST.

HYDROSTATIC PRESSURE TESTING WATER THAT IS RELEASED TO AN UPLAND SILT FENCE AND HAY BALE CONTAINMENT AREA WILL BE DUNE USING WORKSPACE IN AN UPLAND AREA AT THE BEGINNING OR ENDING LOCATION OF EACH SEGMENT (NO TREE CLEARING WILL BE INVOLVED IN THE HYDROSTATIC TEST WATER DISCHARGE). A SPLASH PLATE WILL BE USED TO DIFFUSE THE IMPACT OF THE RELEASED WATER. EASTERN SHORE NATURAL GAS WILL ENSURE THAT NO EROSION OR WATERBODY/WETLAND SEDIMENTATION OCCURS FROM THE TEST WATER RELEASE ACTIVITIES. THE RELEASE RATE WILL BE 500 - 1500 GALLONS PER MINUTE, OR AT A RATE SO AS NOT TO CAUSE ANY SCOURING.

PERMIT TERMINATION:
THE TERMINATION OF THE CONSTRUCTION GENERAL PERMIT WILL REQUIRE SUBMISSION AND ACCEPTANCE OF THE POST CONSTRUCTION VERIFICATION DOCUMENTS, INCLUDING FINAL STABILIZATION THROUGHOUT THE SITE, ALL ELEMENTS OF THE SEDIMENT AND STORMWATER MANAGEMENT PLAN IMPLEMENTED, AND ACCEPTANCE OF THE FINAL OPERATION AND MAINTENANCE PLAN.

- GENERAL:**
- THE CONTRACTOR SHALL CONTACT MISS UTILITY OF DELMARVA AT 1-800-282-8555 FOR UTILITY LOCATIONS WITHIN AND SURROUNDING CONSTRUCTION AREAS NOT LESS THAN 3 DAYS BEFORE PERFORMING ANY EXCAVATION.
 - THE LOCATION OF UNDERGROUND UTILITIES AS INDICATED ON PLANS HAS BEEN OBTAINED FROM EXISTING RECORDS. NEITHER THE OWNER OR THE ARCHITECT/ENGINEER ASSUMES ANY RESPONSIBILITY WHATSOEVER IN RESPECT TO ACCURACY, COMPLETENESS, OR SUFFICIENCY OF INFORMATION SHOWN. THERE IS NO GUARANTEE AS TO THE LOCATION, SIZE AND TYPE OF MATERIALS OF EXISTING UNDERGROUND UTILITIES INDICATED ARE REPRESENTATIVE OF THOSE TO BE ENCOUNTERED DURING CONSTRUCTION. IT SHALL BE THE CONTRACTOR'S RESPONSIBILITY TO DETERMINE THE ACTUAL LOCATION OF ALL SUCH UTILITIES, INCLUDING SERVICE CONNECTIONS TO UNDERGROUND UTILITIES. PRIOR TO CONSTRUCTION, THE CONTRACTOR SHALL NOTIFY THE OWNER OF HIS OPERATIONAL PLANS. IN THE EVENT OF AN UNEXPECTED UTILITY INTERFERENCE DURING CONSTRUCTION, THE CONTRACTOR SHALL IMMEDIATELY NOTIFY THE OWNER. ANY SUCH MAINS AND/OR SERVICES DISTURBED BY THE CONTRACTOR'S OPERATIONS SHALL BE RESTORED IMMEDIATELY AT HIS EXPENSE.
 - LOCATION OF UTILITIES SHOWN ON THIS PLAN IS PROVIDED BY OTHERS AND MANY CIRCUMSTANCES REPRESENTS RELOCATED FACILITIES WHICH ARE SCHEDULED TO BE INSTALLED PRIOR TO THE COMMENCEMENT OF EASTERN SHORE NATURAL GAS CONSTRUCTION AT THE LOCATIONS SHOWN ON THIS PLAN.
 - PRIOR TO PERFORMING ANY EXCAVATION GREATER THAN 6 INCHES, THE CONTRACTOR SHALL COORDINATE WITH SOUTH DISTRICT PUBLIC WORKS AND ALL PRIVATE UTILITY COMPANIES TO DETERMINE THE LOCATION OF UNDERGROUND UTILITY LINES. THE CONTRACTOR SHALL BE RESPONSIBLE FOR COORDINATING WITH ALL ORGANIZATIONS THAT CONTROL EXISTING UNDERGROUND UTILITIES IN THE CONSTRUCTION AREA OR WOULD BE AFFECTED BY CONSTRUCTION WORK AROUND THE EXISTING UTILITIES.
 - THE CONTRACTOR SHALL NOT START EXCAVATION UNTIL ALL UTILITY LINE LOCATIONS HAVE BEEN STAKED OR OTHERWISE CLEARLY MARKED AND DOCUMENTATION FURNISHED TO THE OWNER. ALL MARKINGS SHALL BE CONSIDERED APPROXIMATE, AND UTILITIES OTHER THAN THOSE SHOWN SHALL BE CONSIDERED TO EXIST.
 - THE CONTRACTOR SHALL BE RESPONSIBLE FOR THE DEFINITE LOCATION OF EACH UTILITY WITHIN THE WORK AREA. CARE SHOULD BE EXERCISED DURING EXCAVATION WORK TO AVOID DAMAGING OR DISRUPTING UTILITIES. THE CONTRACTOR SHALL BE RESPONSIBLE FOR REPAIRING (AT CONTRACTOR'S EXPENSE) DAMAGE TO ANY UTILITY CAUSED BY THE CONTRACTOR'S WORK.
 - WHERE EXISTING UNDERGROUND UTILITIES OR OTHER CONSTRUCTION ARE EXPECTED TO BE IN PROXIMITY TO PROPOSED CONSTRUCTION, OR WHEN APPROACHING EXISTING UTILITIES OR STRUCTURES FOR CONNECTIONS, THE CONTRACTOR SHALL DIG TEST PITS TO DETERMINE THE EXACT LOCATION AND INVERTS OF THE EXISTING UTILITY TO ALLOW FOR POSSIBLE CHANGES TO THE PROPOSED UTILITY IN LINE AND/OR GRADE. THE CONTRACTOR SHALL ALSO DIG TEST PITS IN THE LOCATION OF THE PROPOSED CONNECTIONS TO EXISTING UTILITIES AND SHALL MAKE ALL MEASUREMENTS NECESSARY TO ENSURE PROPER CONNECTION. ANY NECESSARY CHANGES IN LINE OR GRADE OF WORK CAUSED BY FAILURE TO TAKE SUCH PRECAUTIONS SHALL BE AT THE EXPENSE OF THE CONTRACTOR.
 - WHEN IT IS NECESSARY TO EXCAVATE NEAR OR INTERFERE WITH ANY SEWER LINE, WATER SERVICES, DRAIN PIPE, CATCH BASIN, CULVERT, OR OTHER STRUCTURES, THE CONTRACTOR SHALL MAINTAIN THE SAME IN WORKING ORDER AND SHALL REPAIR AND MAKE GOOD ANY DAMAGE DONE DURING THE PROGRESS OF THE WORK.
 - WHERE EXISTING UTILITIES CROSS THE TRENCH EXCAVATION, THEY SHALL BE ADEQUATELY SUPPORTED AND PROTECTED FROM DAMAGE DUE TO CONSTRUCTION. ALL METHODS FOR SUPPORTING AND MAINTAINING THESE UTILITIES SHALL BE SUBJECT TO REVIEW BY OWNER. CARE SHALL BE TAKEN TO ENSURE THAT THE EXISTING UTILITY GRADES AND ALIGNMENT ARE MAINTAINED AND THE PIPE JOINTS ARE NOT DISTURBED. BACKFILL SHALL BE CAREFULLY PLACED AND TAMPED TO PREVENT DAMAGE OR FUTURE SETTLEMENT. ANY DAMAGE OR MISALIGNMENT OF THE UTILITY DUE TO CONSTRUCTION OR SETTLEMENT SHALL BE REPAIRED BY THE CONTRACTOR AT THE CONTRACTOR'S EXPENSE.
 - ANY UNPROTECTED CABLE (DIRECT BURIED) ENCOUNTERED THAT IS VERIFIED AS NOT ABANDONED IN PLACE SHALL BE PROTECTED. THE UTILITY OWNER MAY DIRECT THE CABLE BE PLACED IN SPLIT DUCT OF APPROPRIATE SIZE AND CONCRETE ENCASED THROUGH THE AREA OF CONSTRUCTION. CONTRACTOR SHALL TAKE ALL REASONABLE MEASURES TO AVOID HAVING TO CUT AND SPLICE DIRECT BURIED CABLE. THE CONTRACTOR SHALL NOTE SPLIT DUCT PORTIONS ON AS-BUILTS.
 - SHORING MAY BE REQUIRED TO PROTECT THE INTEGRITY OF THE ROADWAY IF TRENCH ENCROACHES WITHIN 5' OF PAVEMENT OR IF UNDERMINING OCCURS.

CONSTRUCTION SCHEDULE

CONSTRUCTION IS SCHEDULED TO BEGIN IN SUMMER 2026. CONSTRUCTION IS SCHEDULED TO BE COMPLETED BY DECEMBER 2026, IN ACCORDANCE WITH ESNG SCHEDULE. WORK WILL CONSIST OF THE FOLLOWING SEQUENTIAL OR CONCURRENT ACTIVITIES:

- THE KENT CONSERVATION DISTRICT SEDIMENT AND STORMWATER MANAGEMENT PROGRAM MUST BE NOTIFIED IN WRITING FIVE (5) DAYS PRIOR TO COMMENCEMENT OF CONSTRUCTION. FAILURE TO DO SO CONSTITUTES A VIOLATION OF THE APPROVED SEDIMENT AND STORMWATER MANAGEMENT PLAN.
- PRIOR TO ANY CLEARING, INSTALLATION OF SEDIMENT CONTROL MEASURE OR GRADING, A PRE-CONSTRUCTION MEETING SHALL BE SCHEDULED AND CONDUCTED WITH THE AGENCY CONSTRUCTION SITE REVIEWER, THE LANDOWNER / DEVELOPER, CONTRACTOR AND CERTIFIED CONSTRUCTION REVIEWER ARE REQUIRED TO BE IN ATTENDANCE AT THE PRE-CONSTRUCTION MEETING; THE DESIGNER IS RECOMMENDED TO ATTEND.
- ALL PERIMETER CONTROLS ARE TO BE REVIEWED BY THE AGENCY CONSTRUCTION SITE REVIEWER AND APPROVED PRIOR TO PROCEEDING WITH FURTHER SITE DISTURBANCE OR CONSTRUCTION.
- EROSION AND SEDIMENTATION CONTROL STRUCTURES WILL BE INSTALLED AND MAINTAINED AS NECESSARY (SEE ENVIRONMENTAL NOTES).
- TOPSOIL STRIPPING AND SEGREGATION WILL BE PERFORMED IN REQUIRED AREAS.
- CLEARING, GRADING AND GRUBBING WILL BE PERFORMED IN NON-ROADWAY AREAS, AS APPLICABLE.
- TRENCHING/DITCHING WILL BE PERFORMED TO ENSURE REQUIRED DEPTH OF COVER OVER PIPELINE PER THE DRAWINGS, (SUBSOIL WILL BE STOCKPILED WITHIN THE WORK AREA SEPARATE FROM TOPSOIL AS APPLICABLE).
- IN PAVED AREAS TRENCHLINE IS TO BE SANKUT, AND PAVEMENT WILL BE DISPOSED OF AT AN APPROVED FACILITY.
- INSTALLATION OF PRE-FABRICATED CONTROL STATION.
- BENDING, WELDING, AND COATING OF THE PIPELINE ALONG THE EDGE OF THE TRENCH.
- LOWERING THE PIPE INTO THE DITCH, PADDING, BACKFILL, AND COMPACTING (INCLUDING ROAD SUB-BASE IN PAVED ROADWAY AREAS), AS WELL AS CLEANUP AND RESTORATION.
- FILLING THE PIPE WITH WATER, HYDROSTATIC PRESSURE TESTING OF THE PIPE AND DENATURING INTO THE UPLAND AREA.
- INSTALLATION OF VALVE ASSEMBLIES AS REQUIRED.
- FINAL TIE-IN OF THE PIPELINE AT BOTH ENDS, FINAL CLEANUP AND GRADING, ROAD RESURFACING WHERE APPLICABLE, AND SEEDING AND MULCHING WHERE APPLICABLE. SEE 'STABILIZATION NOTES' FOR REQUIREMENTS RELATED TO STABILIZATION OF ROADWAY AND NON-ROADWAY AREAS.
- PLACEMENT OF STONE WITHIN STATION LIMITS.
- CONSTRUCTION OF PROPOSED ENTRANCE.
- INSTALLATION OF FENCING AND ALL GROUNDING MATERIALS.
- INSTALLATION OF GENERATOR AND RTU.
- EROSION/SEDIMENT CONTROL BARRIERS SHALL REMAIN IN PLACE UNTIL FINAL REVEGETATION AND RESTORATION ARE DEEMED SUCCESSFUL AND AUTHORIZED FOR REMOVAL BY THE KENT CONSERVATION DISTRICT SEDIMENT & STORMWATER PROGRAM.
- THE TERMINATION OF THE CONSTRUCTION GENERAL PERMIT WILL REQUIRE SUBMISSION AND ACCEPTANCE OF THE POST CONSTRUCTION VERIFICATION DOCUMENTS, INCLUDING FINAL STABILIZATION THROUGHOUT THE SITE, ALL ELEMENTS OF THE SEDIMENT AND STORMWATER MANAGEMENT PLAN IMPLEMENTED, AND ACCEPTANCE OF THE FINAL OPERATION AND MAINTENANCE PLAN.

OWNER'S CERTIFICATION:

"I, NICK HAMMOND, CERTIFY THAT ALL LAND CLEARING, CONSTRUCTION AND DEVELOPMENT SHALL BE DONE PURSUANT TO THE APPROVED PLAN AND THAT RESPONSIBLE PERSONNEL (I.E., BLUE CARD HOLDER) INVOLVED IN THE LAND DISTURBANCE WILL HAVE A CERTIFICATION OF TRAINING PRIOR TO INITIATION OF THE PROJECT, AT A DNREC SPONSORED OR APPROVED TRAINING COURSE FOR THE CONTROL OF EROSION AND SEDIMENT DURING CONSTRUCTION. IN ADDITION, I GRANT THE DNREC SEDIMENT AND STORMWATER PROGRAM AND/OR THE RELEVANT DELEGATED AGENCY THE RIGHT TO CONDUCT ON-SITE REVIEWS."

Nicholas Hammond Digitally signed by Nicholas Hammond
DN: cn=Nick Hammond, o=Eastern Shore Natural Gas, ou=Engineering, email=Nicholas.Hammond@esng.com, c=US
06/19/2026
NICK HAMMOND, ENGINEER
CHESAPEAKE UTILITIES CORPORATION
500 ENERGY LANE, SUITE 200
DOVER, DE 19901
PHONE - (410) 434-1920



REVISIONS			
NO.	DATE	DESCRIPTION	BY



MORRIS & RITCHIE ASSOCIATES, INC.
ENGINEERS, PLANNERS, SURVEYORS AND LANDSCAPE ARCHITECTS
111 RUTHAR DRIVE
NEWARK, DE 19711
(302) 326-2200
MRA@MIRA.COM
© 2026 MORRIS & RITCHIE ASSOCIATES, INC.



6" PROPOSED PIPELINE CAMDEN CONTROLLER KENT COUNTY, DE	
ESNG PROJECT CODE:	6/19/2026
MRA PROJECT NO:	23098 SCALE: N/A
DESIGN/CHECK BY:	JTH/CWB SHEET: 2 OF 18

LEGEND

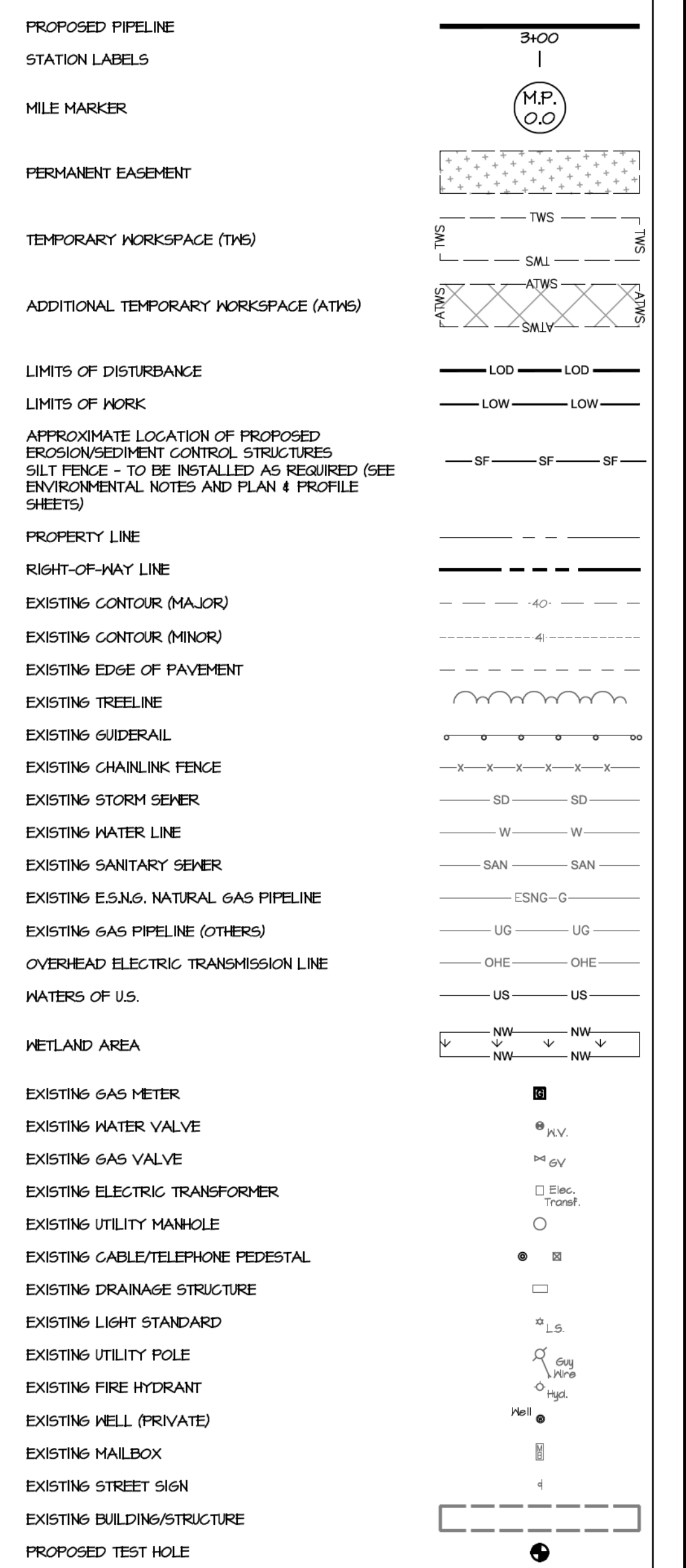

COORDINATE SYSTEM AND VERTICAL DATUM

HORIZONTAL COORDINATE SYSTEM:
DELAWARE STATE PLANE, NORTH AMERICAN DATUM OF 1983 (NAD 83), U.S. SURVEY FOOT

VERTICAL DATUM:
NORTH AMERICAN VERTICAL DATUM OF 1988 (NAVD 88), U.S. SURVEY FOOT



**Know what's below.
Call before you dig.**

PROTECT YOURSELF. GIVE THREE WORKING DAYS NOTICE
THIS DRAWING DOES NOT INCLUDE NECESSARY COMPONENTS FOR CONSTRUCTION SAFETY. ALL CONSTRUCTION MUST BE DONE IN COMPLIANCE WITH THE OCCUPATIONAL SAFETY AND HEALTH ACT OF 1970 AND ALL RULES AND REGULATIONS HERE TO APPURTENANT.

**EROSION & SEDIMENT CONTROL
GENERAL NOTES**

Standard Detail & Specifications
Silt Fence

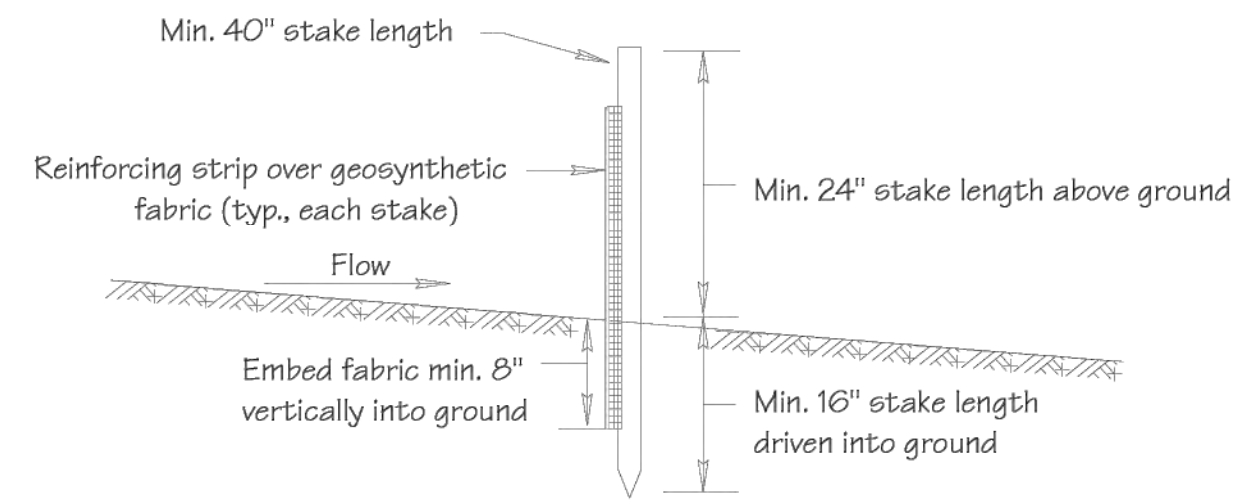

Section

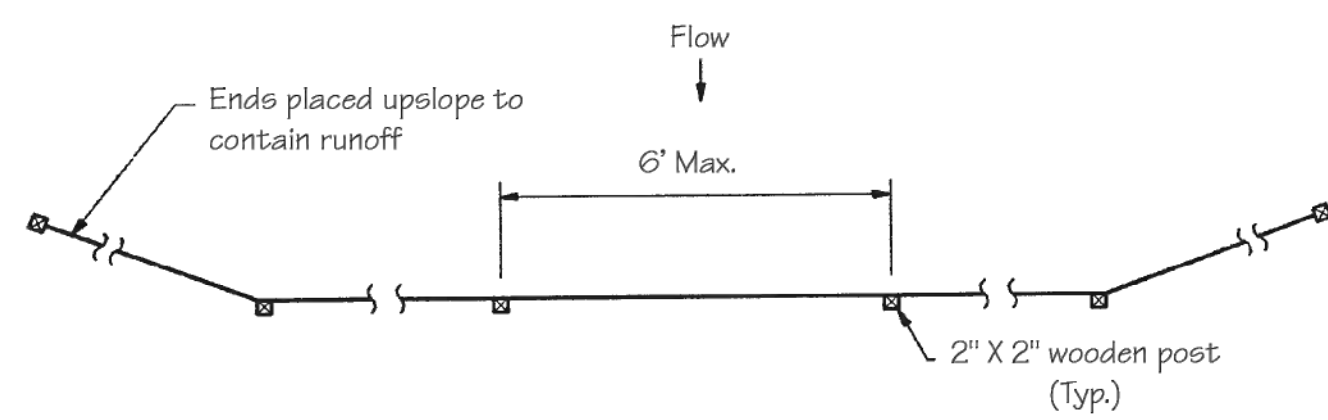

Plan

DATA
Max. controlled slope

Source: Adapted from MD Stds. & Specs. for ESC	Symbol: SF	Detail No. DE-ESC-3.1.2.1 Sheet 1 of 2 Effective January 2026
---	----------------------	---

Standard Detail & Specifications
Silt Fence

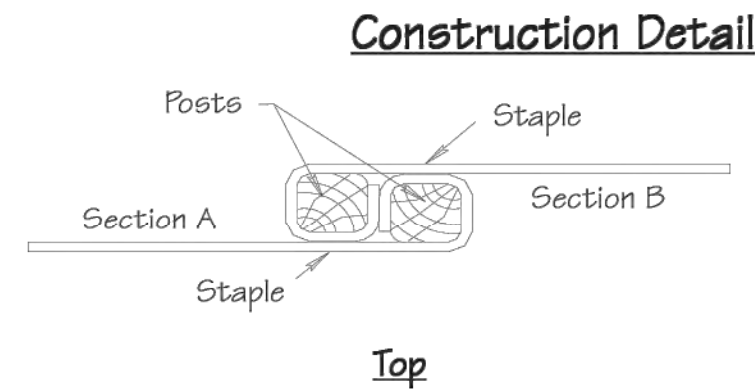

Method for joining continuous sections

Construction Notes:

1. Geosynthetic fabric to be fastened securely to fence posts with wire ties or staples.
2. When two sections of filter cloth adjoin each other they shall be overlapped by six inches and folded.
3. Maintenance shall be performed as needed and material removed when "bulges" develop in the silt fence.

Materials:

1. **Stakes:** Steel (either T or U) or 2" x 2" hardwood
2. **Geosynthetic Fabric:** Type GD-1
3. **Reinforcing strip:** Wooden lath or plastic strip

Source: Adapted from MD Stds. & Specs. for ESC	Symbol: SF	Detail No. DE-ESC-3.1.2.1 Sheet 2 of 2 Effective January 2026
---	----------------------	---

Standard Detail & Specifications
Stabilized Construction Entrance

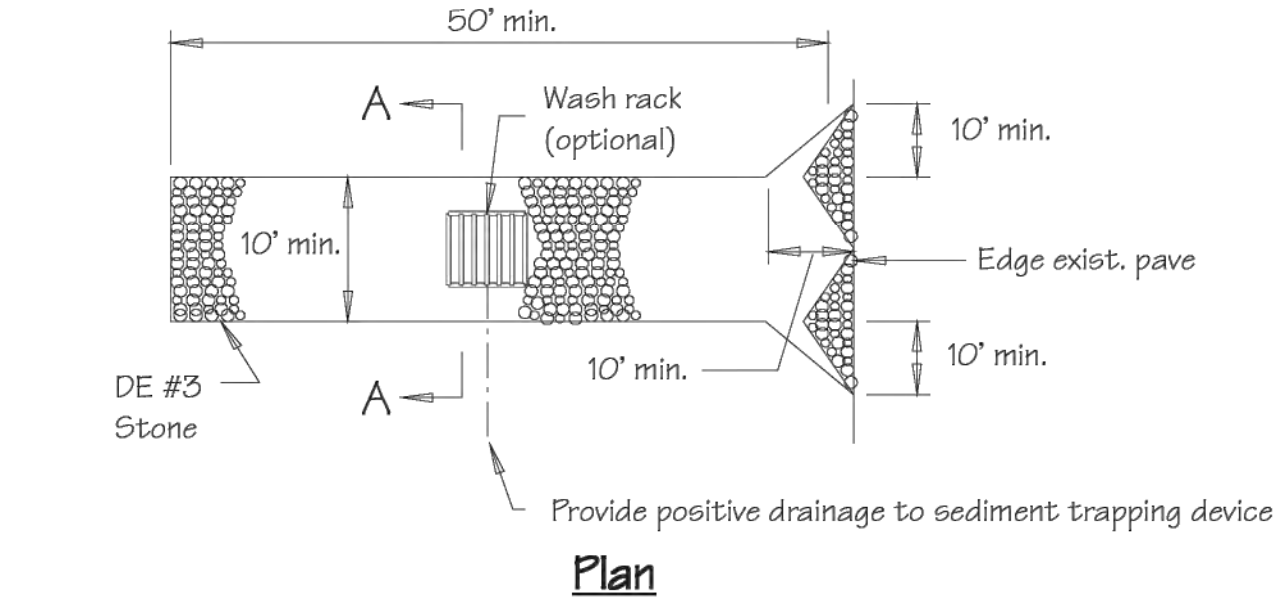

Plan

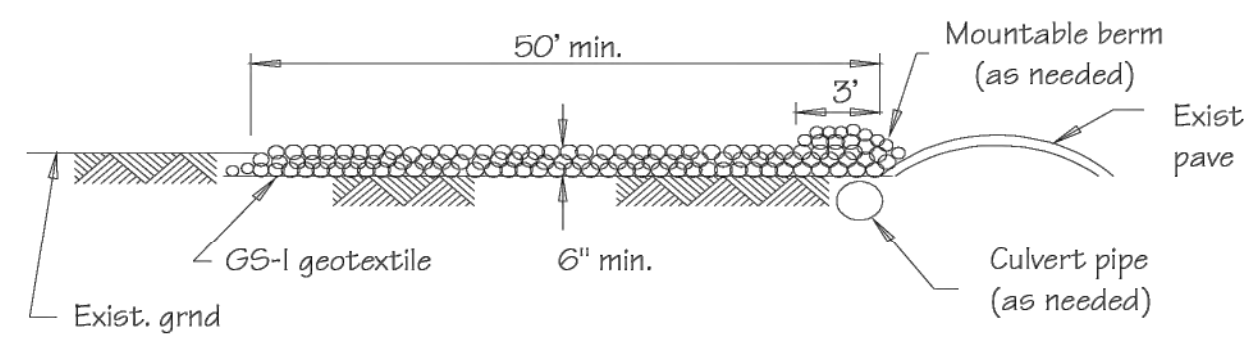

Profile

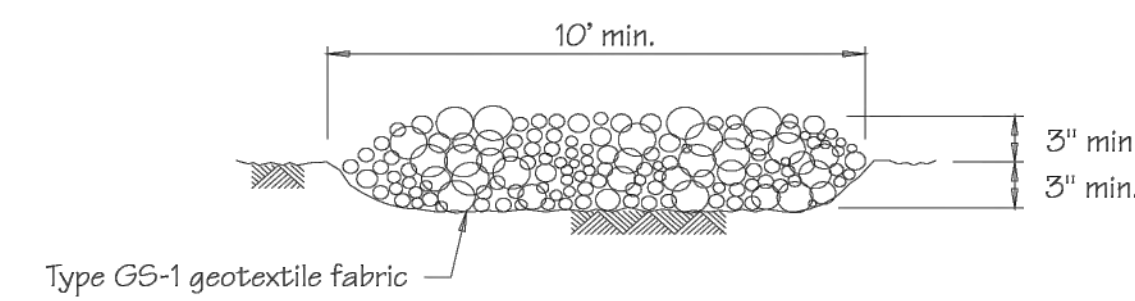

Section A-A (Std.)

Source: Adapted from VA ESC Handbook	Symbol: SCE	Detail No. DE-ESC-3.4.7 Sheet 1 of 2 Effective January 2026
---	-----------------------	---

Standard Detail & Specifications
Stabilized Construction Entrance

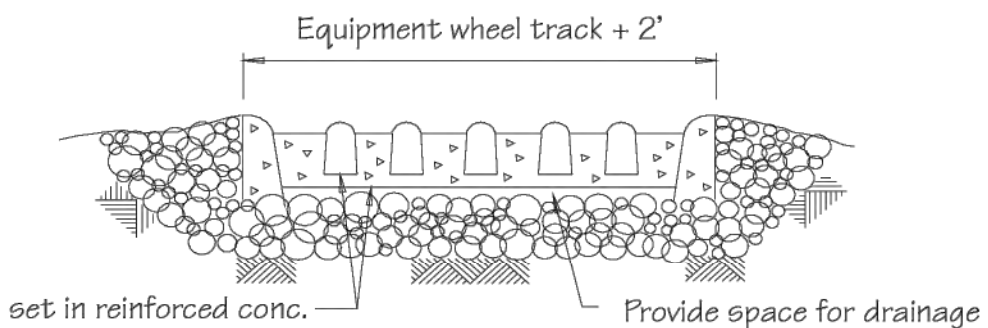

Section A-A (Opt.)

Construction Notes:

1. **Stone size** - Use DE #3 stone.
2. **Length** - As required, but not less than 50 feet (except on a single residence lot where a 30 foot minimum length would apply).
3. **Thickness** - Not less than size (6) inches.
4. **Width** - Ten (10) foot minimum, but not less than the full width at points where ingress or egress occurs.
5. **Geotextile** - Type GS-1; placed over the entire area prior to placing of stone.
6. **Surface Water** - All surface water flowing or diverted toward construction entrances shall be piped across the entrance. If piping is impractical, a mountable berm with 5:1 slopes will be permitted.
7. **Maintenance** - The entrance shall be maintained in a condition which will prevent tracking or flowing of sediment onto public rights-of-way. This may require periodic top dressing with additional stone as conditions demand and repair and/or cleanout of any measures used to trap sediment. All sediment spilled, dropped, washed or tracked onto public rights-of-way must be removed immediately.
8. **Washing** - Vehicle wheels shall be cleaned to remove sediment prior to entrance onto public rights-of-way. When washing is required, it shall be done on an area stabilized with stone and which drains into an approved sediment trapping device.
9. **Inspection** - Periodic inspection and needed maintenance shall be provided after each rain.

Source: Adapted from VA ESC Handbook	Symbol: SCE	Detail No. DE-ESC-3.4.7 Sheet 2 of 2 Effective January 2026
---	-----------------------	---

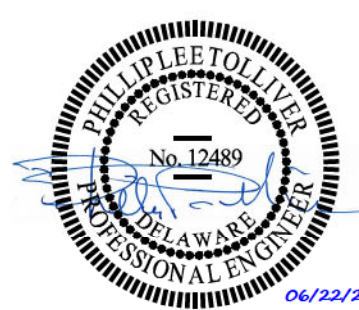

REVISIONS			
NO.	DATE	DESCRIPTION	BY



MORRIS & RITCHIE ASSOCIATES, INC.
ENGINEERS, PLANNERS, SURVEYORS AND
LANDSCAPE ARCHITECTS
111 RUTHAR DRIVE
NEWARK, DE 19711
(302) 326-2200
MRA@TA.COM
© 2026 MORRIS & RITCHIE ASSOCIATES, INC.



EROSION & SEDIMENT CONTROL DETAILS

**6" PROPOSED PIPELINE
CAMDEN CONTROLLER
KENT COUNTY, DE**

ESNG PROJECT CODE:	DATE:	6/19/2026
MRA PROJECT NO:	SCALE:	N/A
DESIGN/CHECK BY:	JTH/CWB	SHEET: 3 OF 18

Standard Detail & Specifications

Construction Site Pollution Prevention

Delaware NPDES Discharge Permit
General Permit for Discharge of Stormwater from Construction Activities

((Project Name))
((NOI Permit Number))
((Agency Plan Approval ID))
((Contact Name & Number for Additional Site Information))
((Contact Name & Number to Obtain Copy of Approved Plan))

If you observe indicators of stormwater pollutants in the discharge or in the receiving waterbody, call the DNREC Spill Notification 24 HR Hotline at

1-800-662-8802

Example Construction General Permit (CGP) Signage

NOTES:

- Minimum sign size 2' x 2'
- Minimum text size 1"
- Sign must be posted at a safe, publicly accessible location close to construction site
- Sign must be visible from the public road nearest the active construction site
- Signs posted within a DelDOT or other public road right-of-way (ROW) must be in accordance with all local and/or State requirements in regards to safety, location, orientation, etc.

Source:	Symbol:	Detail No.
Delaware ESC Handbook		DE-ESC-3.6.1 Sheet 1 of 3 Effective January 2026

Standard Detail & Specifications

Construction Site Pollution Prevention

- 1) Equipment and Vehicle Fueling and Maintenance**
- Minimize spills and leaks of fuels and oils.
 - Fuel only in marked areas a minimum of 50 feet away from drains and watercourses. Use automatic shut-off nozzles and do not top off tanks. Provide lighting if fueling at night.
 - Use berms or other barriers around fueling, maintenance, and parking areas to prevent stormwater from running through and to contain spills. Use drip pans during maintenance.
 - Take equipment and vehicles to off-site facilities for maintenance when possible.
 - Check vehicles and equipment daily for leaks. Repair immediately or remove from site.
 - Clean up any spills right away. Do not hose them down.
 - Keep absorbent materials and spill kits on site, especially in fueling and storage areas.
 - Dispose of or recycle used oil, fluids, lubricants, and cleanup materials according to manufacturer instructions and all local, state, and federal regulations.
- 2) Equipment and Vehicle Washing**
- Minimize discharge of pollutants from wash water.
 - Use off-site commercial wash facilities when possible.
 - If washing on-site, use high-pressure water without detergents in a contained area with an impervious berm.
 - Dispose of concrete washout water only in designated washout areas for hardening and proper disposal.
 - Do not discharge soaps, solvents, or detergents.
 - Store soaps, detergents, and solvents under cover (e.g., plastic sheeting, temporary roofs) or use another effective method to prevent contact with stormwater.
- 3) Storage, Handling, and Disposal of Building Products, Materials, and Waste**
- Minimize exposure of materials, products, and waste to rain, stormwater, and wind.
 - Building materials and products:
 - Cover materials (e.g., plastic sheeting, tarp, or roof) to prevent contact with rain and stormwater. Final building materials and products intended for outdoor use do not require cover.
 - Secure materials (e.g., tarp, mesh, or lidded dumpster) to protect from wind.

Source:	Symbol:	Detail No.
Adapted from USEPA CGP 2022 (as modified)		DE-ESC-3.6.1 Sheet 2 of 3 Effective January 2026

Standard Detail & Specifications

Construction Site Pollution Prevention

- Construction and domestic waste:
 - Provide enough containers (e.g., dumpsters, trash bins) to hold all waste.
 - Keep container lids closed when not in use and during storms.
 - For containers without lids, cover with a tarp or temporary roof to prevent exposure to rain and wind.
 - Do not dump or allow liquid wastes (e.g., paint, solvents, chemicals) to enter the ground, drains, or waterways.
 - Dispose of waste in designated containers and clean up loose trash immediately.
 - Empty dumpsters when at 80% capacity by volume.
 - Waste containers are not required for final building materials and products if stored separately from other construction, domestic or other waste. If mixed, the waste must be managed as construction and domestic waste in Section 3(c).
- 4) Hazardous Materials, Other Chemicals and Sanitary Waste:**
- Store hazardous materials and chemicals under cover or in secondary containment, at least 50 feet from drains or waterways.
 - Keep containers labeled, sealed, watertight, and closed when not in use.
 - Store contaminated waste in sealed, labeled containers made of suitable material.
 - Dispose of hazardous materials according to Delaware laws and regulations.
 - Post spill reporting contact information clearly on site.
- 5) Pesticides, Herbicides, Fertilizers, and Landscape Material:**
- Keep all products labeled and covered (e.g., plastic sheeting or temporary roofs) to prevent contact with rain and stormwater.
 - Provide similarly effective protection methods, such as storing fertilizer in a weatherproof area or on a covered pallet, to minimize polluted run-off.
 - Apply all products according to state and federal regulations.

CONTACT INFORMATION

DNREC 24-Hour Toll Free Number **800-662-8802**
DNREC Solid & Hazardous Waste Management Section **302-739-9403**

Source:	Symbol:	Detail No.
Adapted from USEPA CGP 2022 (as modified)		DE-ESC-3.6.1 Sheet 3 of 3 Effective January 2026

Standard Detail & Specifications

Mulching

1. Materials and Amounts

- Straw - Straw shall be unrotted small grain straw applied at the rate of 1-1/2 to 2 tons per acre, or 70 to 90 pounds (two bales) per 1,000 square feet. Mulch materials shall be relatively free of weeds and shall be free of noxious weeds such as; thistles, Johnsongrass, and quackgrass. Spread mulch uniformly by hand or mechanically. For uniform distribution of hand spread mulch, divide area into approximately 1,000 square feet sections and place 70-90 pounds (two bales) of mulch in each section.
- Wood chips - Apply at the rate of approximately 6 tons per acre or 275 pounds per 1,000 square feet when available and when feasible. These are particularly well suited for utility and road rights-of-way. If wood chips are used, increase the application rate of nitrogen fertilizer by 20 pounds of N per acre (200 pounds of 10-10-10 or 66 pounds of 30-0-0 per acre).
- Hydraulically applied mulch - The following conditions apply to hydraulically applied mulch:
 - Definitions:
 - Wood fiber mulch shall consist of specially prepared wood that has been processed to a uniform state, is packaged for sale as a hydraulic mulch for use with hydraulic seeding equipment, and consists of a minimum of 70% virgin or recycled wood fiber combined with 30% paper fiber and additives.
 - Blended fiber mulch shall consist of any hydraulic mulch that contains greater than 30% paper fiber. The paper component must consist of specially prepared paper that has been processed to a uniform fibrous state and is packaged for sale as a hydraulic mulch for use with hydraulic seeding equipment.
 - A bonded fiber matrix (BFM) consists of long strand, specially prepared wood fibers that have been processed to a uniform state held together by a water resistant bonding agent. BFMs shall contain no paper (cellulose) mulch but may contain small percentages of synthetic fibers to enhance performance.
 - Refer to **Figure 3.4.5a** for conditions and limitations of use for each of the above categories of hydraulic mulch.
 - All components of the hydraulically applied mulches shall be pre-packaged by the manufacturer to assure material performance. Field mixing of the mulch components is acceptable, but must be done per manufacturers recommendations to ensure the proper results.
 - Hydraulic mulches shall be applied with a viable seed and at manufacturer's recommended rates. Increased rates may be necessary based on site conditions.
 - Hydraulically applied mulches and additives shall be mixed according to manufacturers recommendations.
 - Materials within this category shall only be used when hydraulically applied mulch has been specified for use on the approved Sediment and Stormwater Plan, or supplemental approval from the plan approval agency has been obtained in writing for a specific area.

Source:	Symbol:	Detail No.
Delaware ESC Handbook & Filtrex™ International		DE-ESC-3.4.5 Sheet 1 of 3 Effective January 2026

Standard Detail & Specifications

Mulching

- Application:
 - Apply product to geotechnically stable slopes that have been designed and constructed to divert runoff away from the face of the slope.
 - Do not apply to saturated soils, or if precipitation is anticipated within 24-48 hours.
 - During the spring (March 1 to May 31) and fall (September 1 to November 30) seasons, hydraulic mulches may be applied in a one-step process where all components are mixed together in single-tank loads. It is recommended that the product be applied from opposing directions to achieve optimum soil coverage.
 - During the summer (June 1 to August 31) and winter (December 1 to February 28) seasons, the following two-step process is required:
 - Step One** - Mix and apply seed and soil amendments with a small amount of mulch for visual metering.
 - Step Two** - Mix and apply mulch at manufacturers recommended rates over freshly seeded surfaces. Apply from opposing directions to achieve optimum soil coverage.
 - Minimum curing temperature is 40°F (4°C). The best results and more rapid curing are achieved at temperatures exceeding 60°F (15°C). Curing times may be accelerated in high temperature, low humidity conditions on dry soils.
 - Recommended application rates are for informational purposes only. Conformance with this standard and specification shall be performance-based and requires **100% soil coverage**. Any areas with bare soil showing shall be top dressed until full coverage is achieved.
 - Compost blanket (CB)** - Loosely applied with a pneumatic blower so that a 1" compost blanket uniformly covers the soil with **100% coverage**. This application can be used with seed to promote germination by applying the approved seed mix directly into the loosely blown compost. The compost blanket performs best on slopes less than 2:1 and requires no mulch anchoring.
- 2. Anchoring mulch** - Mulch must be anchored immediately to minimize loss by wind or water. This may be done by one of the following methods, depending upon size of area, erosion hazard, and cost.
- Crimping** - A crimper is a tractor drawn implement designed to punch and anchor mulch into the top two (2) inches of soil. This practice affords maximum erosion control but is limited to flatter slopes where equipment can operate safely. On sloping land, crimping should be done on the contour whenever possible.
 - Tracking** - Tracking is the process of cutting mulch (usually straw) into the soil using a bulldozer or other equipment that runs on cleated tracks. Tracking is used primarily on slopes 3:1 or steeper and should be done up and down the slope with clear marks running across the slope.
 - Liquid mulch binders** - Applications of liquid mulch binders should be heavier at edges, in valleys, and at crests of banks and other areas where the mulch will be moved by wind or water. All other areas should have a uniform application of binder. The use of synthetic binders is the preferred method of mulch binding and should be applied at the rates recommended by the manufacturer.
 - Paper fiber** - The fiber binder shall be applied at a net dry weight of 750 lbs/ac. The wood cellulose fiber shall be mixed with water, and the mixture shall contain a maximum of 50 lbs. of wood cellulose fiber per 100 gallons.
 - Nettings** - Biodegradable nettings may be used to secure straw mulch. Install and secure according to the manufacturer's recommendations. Photodegradable or synthetic nettings are not acceptable.

Source:	Symbol:	Detail No.
Delaware ESC Handbook & Filtrex™ International		DE-ESC-3.4.5 Sheet 2 of 3 Effective January 2026

Source:
Delaware ESC Handbook & Filtrex™ International

Symbol:
DE-ESC-3.4.5
Sheet 3 of 3
Effective January 2026

Detail No.
DE-ESC-3.4.5
Sheet 3 of 3
Effective January 2026

MULCHING MATERIAL SELECTION GUIDE						
Percent Slope	Type of Mulch / App. Rate*	Dec. 1 to Feb. 28(29)	March 1 to May 31	June 1 to Aug. 31	Sept. 1 to Nov. 30	
Less than 2%	Blended Fiber @ 2000 lbs/ac. minimum	XXXXXXXXXXXXXXXXXXXX	OK (≤ 1 ac.)	XXXXXXXXXXXXXXXXXXXX	OK (≤ 1 ac.)	OK
	Wood Fiber @ 2500 lbs/ac. min.	XXXXXXXXXXXXXXXXXXXX	OK	XXXXXXXXXXXXXXXXXXXX	OK	OK
	BFM @ 3000 lbs/ac. min.	OK	OK	OK	OK	OK
	Straw @ 2 Tons/ac. Min.	OK	OK	OK	OK	OK
2% to 5.9%	Stabilization Matting**	OK	OK	OK	OK	OK
	1" Compost Blanket (CB)	OK	OK	OK	OK	OK
	Wood Fiber @ 2000 lbs/ac. min.	XXXXXXXXXXXXXXXXXXXX	OK	XXXXXXXXXXXXXXXXXXXX	OK	OK
	BFM @ 3000-3500 lbs/ac. min.	OK	OK	OK	OK	OK
6% to 10.9%	Straw @ 2 Tons/ac. min.	OK	OK	OK	OK	OK
	Stabilization Matting**	OK	OK	OK	OK	OK
	1" Compost Blanket (CB)	OK	OK	OK	OK	OK
	Wood Fiber @ 2000-2500 lbs/ac. min.	XXXXXXXXXXXXXXXXXXXX	OK	XXXXXXXXXXXXXXXXXXXX	OK	OK
11% to 24.9%	BFM @ 3500-4000 lbs/ac. min.	OK	OK	OK	OK	OK
	Straw @ 2 Tons/ac. min.	OK	OK	OK	OK	OK
	Stabilization Matting**	OK	OK	OK	OK	OK
	1" Compost Blanket (CB)	OK	OK	OK	OK	OK
25% to 33%	Wood Fiber @ 2500-3000 lbs/ac. min.	XXXXXXXXXXXXXXXXXXXX	OK	XXXXXXXXXXXXXXXXXXXX	OK	OK
	BFM @ 4000 lbs/ac. min.	XXXXXXXXXXXXXXXXXXXX	OK	XXXXXXXXXXXXXXXXXXXX	OK	OK
	Straw @ 2 Tons/ac. min.	OK	OK	OK	OK	OK
	Stabilization Matting**	OK	OK	OK	OK	OK
33% and up	1" Compost Blanket (CB)	OK	OK	OK	OK	OK
	BFM @ 4000-4500 lbs/ac. min.	XXXXXXXXXXXXXXXXXXXX	OK	XXXXXXXXXXXXXXXXXXXX	OK	OK
	Straw @ 2 Tons/ac. min.***	OK	OK	OK	OK	OK
	Stabilization Matting**	OK	OK	OK	OK	OK
	1" Compost Blanket (CB)	2:1 Max.	2:1 Max.	2:1 Max.	2:1 Max.	2:1 Max.

* Note: Manufacturers Recommended Rates for informational purposes only. Performance standard requires 100% soil coverage.
** Note: Stabilization Matting must be applied in accordance with Section 3.4.6 of the Delaware ESC Handbook.
*** Note: Straw applied on slopes greater than 3:1 must be netted (this does not apply to topsoil stockpiles).
OK = Acceptable to use during this time period.
xxx = Not acceptable to use during this time period.
All application rates are minimums.

Standard Detail & Specifications
Mulching

EROSION & SEDIMENT CONTROL DETAILS

6" PROPOSED PIPELINE
CAMDEN CONTROLLER
KENT COUNTY, DE

ESNG PROJECT CODE:	DATE:
MRA PROJECT NO: 23098	SCALE: N/A
DESIGN/CHECK BY: JTH/CWB	SHEET: 4 OF 18



REVISIONS			
NO.	DATE	DESCRIPTION	BY

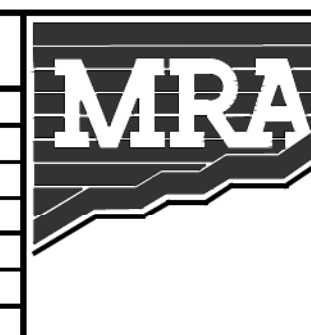

MORRIS & RITCHIE ASSOCIATES, INC.
ENGINEERS, PLANNERS, SURVEYORS AND LANDSCAPE ARCHITECTS
111 RUTHAR DRIVE
NEWARK, DE 19711
(302) 326-2200
MRA@MIRA.COM
© 2026 MORRIS & RITCHIE ASSOCIATES, INC.



Standard Detail & Specifications
Vegetative Stabilization

TEMPORARY SEEDING BY RATES, DEPTHS AND DATES										
Mix #	Species ²	Seeding Rate	Optimum Seeding Dates ¹						Planting Depth ³	
			Coastal Plain		Piedmont		All			
Certified Seed		lb/Ac ⁴	lb/1000 sq.ft.	2/1-4/30	5/1-8/14	8/15-10/31	3/1-4/30	5/1-7/31	8/1-10/31	10/31-2/1
1	Barley	125	4	O	A	O	O	A	O	1-2 inches
2	Oats	125	4	O	A	A	O	A	O	2-3" sandy soils
3	Rye	125	4	O	A	O	O	A	O	1-2 inches
4	Perennial Ryegrass	125	4	O	A	O	O	A	O	2-3" sandy soils
5	Annual Ryegrass	125	4	O	A	O	O	A	O	0.5 inches
6	Winter Wheat	125	4	O	A	O	O	A	O	1-2 inches
7	Foxtail Millet	30 PLS	0.7	O						0.5 inches
8	Pearl Millet	20 PLS	0.5	O						1-2" sandy soils

- Winter seeding requires 3 tons per acre of straw mulch for proper stabilization.
- May be planted throughout summer if soil moisture is adequate or seeded area can be irrigated.
- Applicable on slopes 3:1 or less.
- Use varieties currently recommended for Delaware. Contact a County Extension Office for information.
- Warm season grasses such as Millet may be used between 5/1 and 9/1 if desired. Seed at 3-5 lbs. per acre. Good on low fertility and acid areas. Seed after frost through summer at a depth of 0.5".

NOTE: Alternative seed mixes may be used with prior approval from the Department or Delegated Agency.

* PREFERRED SEED MIX

Source:	Symbol:	Detail No.
Delaware ESC Handbook		DE-ESC-3.4.3 Sheet 1 of 4 Effective January 2026

Standard Detail & Specifications
Vegetative Stabilization

PERMANENT SEEDING AND SEEDING DATES												
Mix No.	Certified Seed ²	Seeding Rate ¹	Optimum Seeding Dates ²						Remarks			
			Coastal Plain		Piedmont		All ³					
Well Drained Soils		lb/Ac	lb/1000 sq.ft.	2/1-4/30	5/1-8/14	8/15-10/31	3/1-4/30	5/1-7/31	8/1-10/31	10/31-2/1		
1	Tall Fescue Canada Wild Rye	140 10	3.2 0.23	A	O	A	O	A	O	A	Good erosion control mix Tolerant of low fertility soils Good for droughty sites	
2	Dwarfing Sheep Fescue White Clover	30 10	0.89 0.69	A	O	A	O	A	O	A	Good erosion control mix Tolerant of low fertility soils Legume that fixes atmospheric N into soil	
3	Tall Fescue (Turf-type) or Strong Creeping Red Fescue or Perennial Ryegrass	50 50	1.15 1.15	O	A ⁴	O	O	A ⁴	O	O	Good erosion control mix Tall Fescue for droughty conditions. Creeping Red Fescue for heavy shade. Flatpea to suppress woody vegetation.	
4	Strong Creeping Red Fescue Kentucky Bluegrass Perennial Ryegrass or Redtop plus White Clover ⁵	100 70 50 5	2.3 1.81 0.35 0.11	O	A ⁴	O	O	A ⁴	O	O	Suitable waterway mix. Canada Bluegrass more drought tolerant. Use Redtop for increased drought tolerance.	
5	Switchgrass ⁶ or Coastal Panicgrass Big Bluestem Little Bluestem Indian Grass	10 10 5 5	0.23 0.23 0.11 0.11	O							Native warm-season mixture. Tolerant of low fertility soils. Drought tolerant. Poor shade tolerance. N fertilizer discouraged - weeds	
6	Tall Fescue (Turf-type) (Blend of 3 cultivars)	150	3.5	O	A ⁴	O	O	A ⁴	O	O	Managed filter strip for nutrient uptake.	
7	Tall Fescue Ky. Bluegrass (Blend) Perennial Ryegrass	150 20 20	3.5 0.46 0.46	O	A ⁴	O	O	A ⁴	O	O	Three cultivars of Kentucky Bluegrass. Traffic tolerant.	
8	Big Bluestem Indian Grass ⁷ Little Bluestem ⁷ Creeping Red Fescue plus one of: Partridge Pea Bush Clover Wild Indigo Showy Tick-Tree	10 10 8 30 3 3 2	0.23 0.23 0.18 0.69 0.07 0.07 0.05	O	A ⁴	O	O	A ⁴	O	O	All species are native. Indian Grass and Bluestem have fully seeds. Plant with a specialized native seed drill. Creeping Red Fescue will provide erosion protection while the warm season grasses get established.	

NOTE: Alternative seed mixes may be used with prior approval from the Department or Delegated Agency.

Source:	Symbol:	Detail No.
Delaware ESC Handbook		DE-ESC-3.4.3 Sheet 2 of 4 Effective January 2026

Standard Detail & Specifications
Vegetative Stabilization

PERMANENT SEEDING AND SEEDING DATES (cont.)												
Mix No.	Certified Seed ²	Seeding Rate ¹	Optimum Seeding Dates ²						Remarks			
			Coastal Plain		Piedmont		All ³					
Poorly Drained Soils		lb/Ac	lb/1000 sq.ft.	2/1-4/30	5/1-8/14	8/15-10/31	3/1-4/30	5/1-7/31	8/1-10/31	10/31-2/1		
9	Redtop Creeping Bentgrass Sheep Fescue Rough Bluegrass	75 35 30 45	1.72 0.8 0.69 1	O	A ⁴	O	O	A ⁴	O	O	Add 100 lbs./ac. Winter Rye	
10	Switchgrass ⁶	10	0.23	A							Good erosion control, wildlife cover and wetland revegetation.	
Residential Lawns												
11	Tall Fescue Perennial Ryegrass Kentucky Bluegrass Blend	100 25 25	2.3 0.57 0.69	O	A ⁴	O	O	A ⁴	O	O	High value, high maintenance, light traffic, irrigation necessary. Well drained soils, full sun.	
12	Tall Fescue Perennial Ryegrass Sheep Fescue	100 25 25	2.3 0.57 0.69	O	A ⁴	O	O	A ⁴	O	O	Moderate value, low maintenance, traffic tolerant.	
13	Creeping Red Fescue Chewings Fescue Rough Bluegrass Kentucky Bluegrass	50 50 20 20	1.15 1.15 0.4 0.4	O	A ⁴	O	O	A ⁴	O	O	Shade tolerant, moderate traffic tolerance, moderate maintenance.	
14	Creeping Red Fescue Rough Bluegrass or Chewings Fescue	50 80	1.15 2.1	O	A ⁴	O	O	A ⁴	O	O	Shade tolerant, moisture tolerant.	
15	K-31 Tall Fescue	150	3.5	O	A ⁴	O	O	A ⁴	O	O	Monoculture, but performs well alone in lawns. Discouraged.	

- When hydroseeding is the chosen method of application, the total rate of seed should be increased by 25%.
- Winter seeding requires 3 tons per acre of straw mulch. Planting dates listed above are average for Delaware. These dates may require adjustment to reflect local conditions.
- All seed shall meet the minimum purity and minimum germination percentages recommended by the Delaware Department of Agriculture. The maximum % of seed seeds shall be in accordance with Chapter 15, Title 3 of the Delaware Code.
- Turf-type species may be planted throughout summer if soil moisture is adequate or seeded area can be irrigated.
- It is recommended that all leguminous seed be inoculated.
- Warm season grass mix and Switchgrass cannot be mowed more than 4 times per year.
- Warm season grasses require a soil temperature of at least 50 degrees in order to germinate and will remain dormant until then.

* PREFERRED SEED MIX

NOTE: Alternative seed mixes may be used with prior approval from the Department or Delegated Agency.

Source:	Symbol:	Detail No.
Delaware ESC Handbook		DE-ESC-3.4.3 Sheet 3 of 4 Effective January 2026

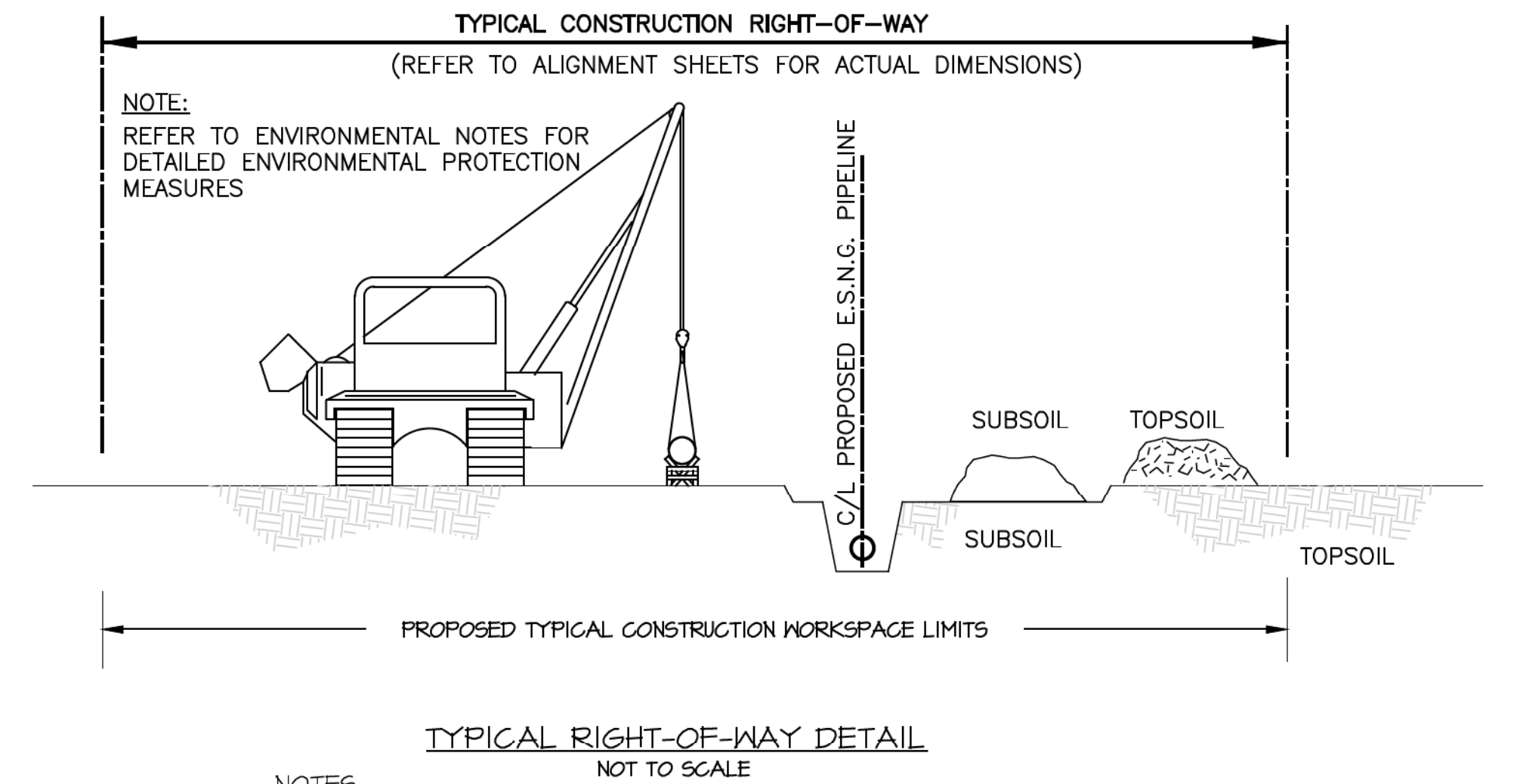

- NOTES:
- RIGHT OF WAY CONFIGURATION VARIES, SEE PLAN AND PROFILE SHEETS
 - CONFIGURATION DOES NOT INCLUDE ADDITIONAL TEMPORARY WORKSPACE FOR STAGING, CROSSINGS AND PIPE STORAGE.

NOTE: THE CONTRACTOR SHALL PERFORM SOIL BORES AND/OR TEST PITS AS REQUIRED TO ASSESS THE FEASIBILITY OF DRILLING OPERATIONS. ONCE FEASIBILITY HAS BEEN DETERMINED, THE CONTRACTOR ASSUMES RESPONSIBILITY FOR ANY ADDITIONAL EXPENSES DUE TO UNFORESEEN SOIL OR BEDROCK CONDITIONS.

NO WETLAND OR WATERBODY SHALL BE IMPACTED BY A HORIZONTAL DIRECTIONAL DRILLING (HDD) OPERATION.

ALL DRILLING MUD IS TO BE CONTAINED DURING CONSTRUCTION WITH BERMS, MUD PITS AND EROSION AND SEDIMENTATION CONTROLS DEEMED APPROPRIATE FOR THE SITE. ALL DRILLING MUD SHALL BE PROPERLY DISPOSED OF AT AN APPROVED FACILITY.

THE CONTRACTOR IS RESPONSIBLE FOR PROVIDING TRAFFIC CONTROL DEVICES FOR THE MAINTENANCE AND PROTECTION OF TRAFFIC, WHILE SEGREGATING TRAVEL LANES FROM WORK AREAS UTILIZED FOR HDD OPERATIONS.

Standard Detail & Specifications
Vegetative Stabilization

Construction Notes:

- Site Preparation
 - Prior to seeding, install needed erosion and sediment control practices such as diversions, grade stabilization structures, berms, dikes, grassed waterways, and sediment basins.
 - Final grading and shaping is not necessary for temporary seedings.
- Seedbed Preparation

It is important to prepare a good seedbed to ensure the success of establishing vegetation. The seedbed should be well prepared, loose, uniform, and free of large clods, rocks, and other objectionable material. The soil surface should not be compacted or crusted.
- Soil Amendments
 - Lime - Apply liming materials based on the recommendations of a soil test in accordance with the approved nutrient management plan. If a nutrient management plan is not required, apply dolomitic limestone at the rate of 1 to 2 tons per acre. Apply limestone uniformly and incorporate into the top 4 to 6 inches of soil.
 - Fertilizer - Apply fertilizer based on the recommendations of a soil test in accordance with the approved nutrient management plan. If a nutrient management plan is not required, apply a formulation of 10-10-10 at the rate of 600 pounds per acre. Apply fertilizer uniformly and incorporate into the top 4 to 6 inches of soils.
- Seeding
 - For temporary stabilization, select a mixture from Sheet 1. For a permanent stabilization, select a mixture from Sheet 2 or Sheet 3 depending on the conditions. Alternative seed mixes may be used with prior approval from the Department or Delegated Agency.
 - Apply seed uniformly with a broadcast seeder, drill, cultipacker seeder or hydroseeder. All seed will be applied at the recommended rate and planting depth.
 - Seed that has been broadcast should be covered by raking or dragging and then lightly tamped into place using a roller or cultipacker. If hydroseeding is used and the seed and fertilizer is mixed, they will be mixed on site and the seeding shall be done immediately and without interruption.
- Mulching

All mulching shall be done in accordance with detail DE-ESC-3.4.5.

Source:	Symbol:	Detail No.
Delaware ESC Handbook		DE-ESC-3.4.3 Sheet 4 of 4 Effective January 2026

Standard Detail & Specifications
Topsoiling

Construction Notes:

- Site Preparation (Where Topsoil is to be added)

Note: When topsoiling, maintain needed erosion and sediment control practices such as diversions, grade stabilization structures, berms, dikes, waterways and sediment basins.

 - Grading - Grades on the areas to be topsoiled which have been previously established shall be maintained.
 - Liming - Where the topsoil is either highly acid or composed of heavy clays, ground limestone shall be spread at the rate of 4-8 tons/acre (200-400 pounds per 1,000 square feet). Lime shall be distributed uniformly over designated areas and worked into the soil in conjunction with tillage operations as described in the following procedures.
 - Tilling - After the areas to be topsoiled have been brought to grade, and immediately prior to dumping and spreading the topsoil, the subgrade shall be loosened by discing or by scarifying to a depth of at least 3 inches to permit bonding of the topsoil to the subsoil. Pack by passing a bulldozer up and down over the entire surface area of the slope to create horizontal erosion check slots to prevent topsoil from sliding down the slope.
- Topsoil Material and Application

Note: Topsoil salvaged from the existing site may often be used but it should meet the same standards as set forth in these specifications. The depth of topsoil to be salvaged shall be no more than the depth described as a representative profile for that particular soil type as described in the soil survey published by USDA-SCS in cooperation with Delaware Agricultural Experimental Station.

Source:	Symbol:	Detail No.
USDA - NRCS		DE-ESC-3.4.1 Sheet 1 of 2 Effective January 2026

Standard Detail & Specifications
Topsoiling

Construction Notes (cont.)

- Materials - Topsoil shall be a loam, sandy loam, clay loam, silt loam, sandy clay loam, loamy sand or other soil as approved by an agronomist or soil scientist. It shall not have a mixture of contrasting textured subsoil and contain no more than 5 percent by volume of cinders, stones, slag, coarse fragment, gravel, sticks, roots, trash or other extraneous materials larger than 1-1/2 inches in diameter. Topsoil must be free of plants or plant parts of bermudagrass, quackgrass, Johnsongrass, nutsedge, poison ivy, thistles, or others as specified. All topsoil shall be tested by a reputable laboratory for organic matter content, pH and soluble salts. A pH of 6.0 to 7.5 and an organic content of not less than 1.5 percent by weight is required. If pH value is less than 6.0 lime shall be applied and incorporated with the topsoil to adjust the pH to 6.5 or higher. Topsoil containing soluble salts greater than 500 parts per million shall not be used.

Note: No sod or seed shall be placed on soil which has been treated with soil sterilant or chemicals used for weed control until sufficient time has elapsed to permit dissipation of toxic materials.
- Grading - The topsoil shall be uniformly distributed and compacted to a minimum of four (4) inches. Spreading shall be performed in such a manner that sodding or seeding can proceed with a minimum of additional soil preparation and tillage. Any irregularities in the surface resulting from topsoiling or other operations shall be corrected in order to prevent the formation of depressions or water pockets. Topsoil shall not be placed while in a frozen or muddy condition, when the subgrade is excessively wet, or in a condition that may otherwise be detrimental to proper grading and seedbed preparation.

Note: Topsoil substitutes or amendments as approved by a qualified agronomist or soil scientist, may be used in lieu of natural topsoil. Compost material used to improve the percentage of organic matter shall be provided by a certified supplier.

Compost amendments that are intended to meet specific post-construction stormwater management goals shall further meet the requirements of Appendix 3.06.2 Post Construction Stormwater Management BMP Standards and Specifications, Section 14.0 Soil Amendments.

Source:	Symbol:	Detail No.
USDA - NRCS		DE-ESC-3.4.1 Sheet 2 of 2 Effective January 2026

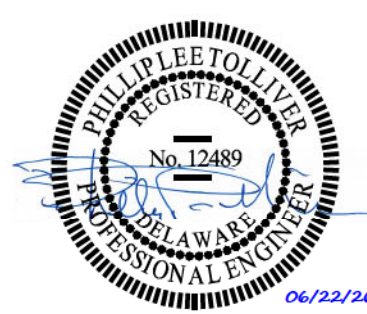

REVISIONS			
NO.	DATE	DESCRIPTION	BY

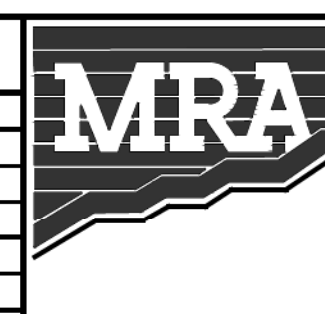

MORRIS & RITCHIE ASSOCIATES, INC.
ENGINEERS, PLANNERS, SURVEYORS AND LANDSCAPE ARCHITECTS
111 RUTHAR DRIVE
NEWARK, DE 19711
(302) 734-2200



6" PROPOSED PIPELINE CAMDEN CONTROLLER KENT COUNTY, DE			
ESNG PROJECT CODE:	DATE:	6/19/2026	
MRA PROJECT NO:	SCALE:	N/A	
DESIGN/CHECK BY:	SHEET:	5 OF 18	

EROSION & SEDIMENT CONTROL DETAILS

DELDOT UTILITY PLAN GENERAL NOTES

- PLANS ARE REVIEWED FOR GENERAL CONFORMITY. DELDOT IS NOT RESPONSIBLE FOR ERRORS OR OMISSIONS WITHIN THE PLAN SET. THE UTILITY OWNER IS RESPONSIBLE TO ENSURE ACCURACY OF PLANS AND CONFORMANCE WITH DELDOT STANDARDS.
- ALL BACKFILL MATERIAL IN EXISTING/PROPOSED ROADWAY SHALL CONFORM TO TYPE "C" BORROW. ALL BORROW BACKFILL SHALL BE COMPACTED TO 95% USING AASHTO T99 STANDARD FOR TESTING.
- 6ABC PLACED SHALL BE COMPACTED TO 98%.
- COMPACTION TESTING SHALL BE PERFORMED EVERY 100' AND TESTING SHALL BE TAKEN ON EACH LIFT OF MATERIAL PLACED (WHEN UTILITY IS IN THE ROADWAY).
- TAR CHIP/HOT MIXES ROADS: TRAVEL WAY PAVEMENT DISTURBED SHALL BE RESTORED AT THE END OF THE DAY PRIOR TO REOPENING TO TRAFFIC. HOT MIX SHALL BE PLACED PER TEMP PATCHING DETAIL 6" 6ABC AND 2" TYPE "C" HOT MIX.
- TAR CHIP/HOT MIXES SHOULDERS: SHOULDERS DISTURBED MAY BE LEFT IN 6ABC TO FINISH GRADE OVERNIGHT BUT SHALL BE CLOSED USING APPROPRIATE SIGNING AND DRUMS. TEMP PAVEMENT SHALL BE PLACED FOR SHOULDERS AT THE END OF EACH WORK PERIOD.
- IF THE REMAINING PORTION OF HOTMIX BETWEEN THE PIPE TRENCH EXCAVATION AND EDGE OF PAVEMENT IS LESS THAN 3' THE REMAINING SECTION SHALL BE REMOVED AND REPAVED AS PART OF THE FULL DEPTH PAVING RESTORATION.
- ALL AREAS DISTURBED OUTSIDE OF THE PAVEMENT SHALL BE GRADED EACH DAY TO ENSURE POSITIVE DRAINAGE AND SHALL BE PERMANENTLY RESTORED AT THE END OF EACH WEEK.
- ALL TEMPORARY HOT MIX SHALL BE PLACED TO PROVIDE A SMOOTH RIDABLE SURFACE TO DELDOT STANDARDS.
- A SAFETY EDGE IS REQUIRED ON ALL HOT MIX PLACED.
- ANY STRIPING DISTURBED SHALL BE PLACED AT THE END OF THE DAY PRIOR TO OPENING TO TRAFFIC.
- PROOF ROLL OF 6ABC SHALL BE PERFORMED USING A LOADED 10 WHEELER PRIOR TO PLACEMENT OF HOT MIX.
- ALL MATERIALS AND WORKMANSHIP WITHIN THE STATE R/M SHALL BE COMPLETED IN ACCORDANCE WITH CURRENT STATE OF DELAWARE DEPARTMENT OF TRANSPORTATION STANDARD SPECIFICATION FOR ROAD AND BRIDGE CONSTRUCTION, SUPPLEMENTAL SPECIFICATIONS, STANDARD CONSTRUCTION DETAILS, UTILITY MANUAL, SPECIAL PROVISIONS AND DESIGN MEMORANDUMS.
- THERE IS A ONE YEAR WARRANTY ON ALL EARTH WORK AND CONCRETE. A THREE YEAR WARRANTY ON ALL HOT MIX INCLUDING SUBBASE/SUBGRADE ISSUES WITHIN THE PAVEMENT AREAS. WARRANTY DOES NOT START UNTIL ALL WORK IS COMPLETED AND A STAND OF GRASS HAS BEEN ESTABLISHED TO DELDOT STANDARDS AND A ACCEPTANCE LETTER HAS BEEN ISSUED.
- ALL DISTURBED AREAS WITHIN THE STATE RIGHT-OF-WAY, BUT NOT IN THE PAVEMENT, SHALL BE TOP-SOILED (6" MINIMUM), FERTILIZED, SEEDED AND MULCHED. IF SOD IS USED NEXT TO SIDEWALK OR SHARED-USE PATH, CONTRACTOR SHALL GRADE TOPSOIL ADJACENT TO THE SIDEWALK OR SHARED-USE PATH PRIOR TO PLACEMENT OF SOD TO ENSURE THAT SOD IS PLACED FLUSH OR JUST BELOW EDGE OF SIDEWALK OR SHARED-USE PATH TO AVOID WATER PONDING ON THE SIDEWALK OR SHARED-USE PATH.
- A 12-HOUR (MINIMUM) NOTICE SHALL BE GIVEN TO THE DELDOT DISTRICT PERMIT SUPERVISOR PRIOR TO STARTING UTILITY CONSTRUCTION.
- A 48 HOUR NOTICE IS REQUIRED TO BE GIVEN TO THE DELDOT INSPECTOR PRIOR TO MATERIAL RELEASES.
- ALL CONCRETE/HOT MIX MATERIALS SHALL BE RELEASED BY THE INSPECTOR PRIOR TO PLACEMENT.
- MISS UTILITY OF DELAWARE SHALL BE NOTIFIED THREE (3) CONSECUTIVE WORKING DAYS PRIOR TO EXCAVATION AT 1-800-282-8555.
- ALL SIGNING, STRIPING AND MAINTENANCE OF TRAFFIC IS THE CONTRACTOR'S RESPONSIBILITY AND SHALL FOLLOW THE GUIDELINES SHOWN IN THE DELAWARE MANUAL ON UNIFORM TRAFFIC CONTROL DEVICES (DE MUTCD) FOR STREETS AND HIGHWAYS (LATEST EDITION). THE OWNER OR MAINTENANCE CORPORATION SHALL BE RESPONSIBLE FOR MAINTENANCE OF ALL SIGNS INSTALLED AS PART OF THIS PROJECT.
- A COPY OF THE UP TO DATE APPROVED CONSTRUCTION DOCUMENTS AND DELDOT APPROVAL LETTERS SHALL BE MAINTAINED ON THE PROJECT SITE AT ALL TIMES AND BE AVAILABLE FOR INSPECTION BY DELDOT PERSONNEL.
- EXISTING UTILITIES ARE SHOWN IN ACCORDANCE WITH THE BEST AVAILABLE INFORMATION. COMPLETENESS OR CORRECTNESS THEREOF IS NOT GUARANTEED. IT SHALL BE THE CONTRACTOR'S RESPONSIBILITY TO CONTACT THE UTILITY COMPANIES INVOLVED IN ORDER TO SECURE THE MOST ACCURATE INFORMATION AVAILABLE AS TO UTILITY LOCATION AND ELEVATION. NO CONSTRUCTION SHOULD OR ADJACENT TO UTILITIES SHALL BEGIN WITHOUT NOTIFYING THEIR OWNERS AT LEAST 48-HOURS IN ADVANCE. THE CONTRACTOR SHALL TAKE THE NECESSARY PRECAUTIONS TO PROTECT THE EXISTING UTILITIES AND MAINTAIN UNINTERRUPTED SERVICE AND ANY DAMAGE DONE TO THEM DUE TO HIGHER NEGLIGENCE SHALL BE IMMEDIATELY AND COMPLETELY REPAIRED AT THE CONTRACTOR'S EXPENSE. TO LOCATE EXISTING UTILITIES IN THE FIELD PRIOR TO CONSTRUCTION, THE CONTRACTOR SHALL CONTACT MISS UTILITY OF DELAWARE (SEE NOTE #5).
- SHOULD UTILITY RELOCATION BE REQUIRED, THE DEVELOPER MUST SUBMIT A UTILITY RELOCATION PLAN FOR DELDOT REVIEW ALONG WITH CORRESPONDENCE FROM THE UTILITY COMPANIES STATING PRELIMINARY APPROVAL TO THE RELOCATION AND DESIGN OF THE UTILITIES PRIOR TO THE DELDOT PRE-CONSTRUCTION MEETING. NO PHYSICAL CONSTRUCTION CAN OCCUR UNTIL THE UTILITY PLANS ARE APPROVED, THE INDIVIDUAL UTILITY COMPANIES ISSUE FINAL APPROVAL, AND A DELDOT UTILITY PERMIT IS ISSUED TO THE UTILITY COMPANY.
- DESIGN AND INSTALLATION OF ALL PAVEMENT MARKINGS AND STRIPING SHALL BE AS OUTLINED IN THE LATEST VERSION OF THE DE MUTCD. FOR FINAL PERMANENT PAVEMENT MARKINGS EPOXY RESIN PAINT SHALL BE REQUIRED FOR LONG LINE STRIPING. THERMO PLASTIC (EXTRUDED OR PREFORMED MATERIAL) WILL BE REQUIRED ON ASPHALT SURFACES, FOR SHORT LINE STRIPING, I.E. SYMBOLS/LEGENDS. PERMANENT PAVEMENT MARKING TAPE (PER DELDOT APPROVED MATERIALS LIST) WILL BE REQUIRED ON CONCRETE SURFACES, FOR SHORT LINE STRIPING, I.E. SYMBOLS/LEGENDS.
- BREAKAWAY POSTS SHALL BE USED WHEN INSTALLING ALL SIGNS. REFERENCE DELDOT STANDARD CONSTRUCTION DETAIL T-5.
- IT IS THE CONTRACTOR'S RESPONSIBILITY TO INSURE THAT PAVING WITHIN THE STATE OF DELAWARE RIGHT-OF-WAY IS INSTALLED TO THE ELEVATIONS SHOWN AND THAT NO PONDING OF WATER EXISTS AFTER PAVING IS COMPLETE.
- ALL PERSONS WORKING WITHIN THE STATE RIGHT-OF-WAY SHALL WEAR A MINIMUM OF AN ANSI CLASS II SAFETY VEST MEETING OR EXCEEDING THE ANSI 107-2004 REQUIREMENTS, AS SPECIFIED IN THE DELAWARE MUTCD.
- WITHIN THE MAINLINE WORK AREA, PERMANENT ADVANCE WARNING SIGNS WITH THE LEGENDS ROAD WORK 1500 FT, ROAD WORK 1000 FT AND ROAD WORK 500 FT SHALL BE INSTALLED IN ADVANCE OF THE WORK AREA IN BOTH DIRECTIONS. AN END ROAD WORK SIGN SHALL BE LOCATED 500 FEET DOWNSTREAM FROM THE WORK AREA. ON INTERSECTING ROADWAYS WITHIN THE PROJECT LIMITS, A ROAD WORK AHEAD SIGN SHALL BE PLACED AT A DISTANCE NOT LESS THAN 500 FEET IN ADVANCE OF THE WORK AREA AND AN END ROAD WORK SIGN SHALL BE LOCATED 500 FEET DOWNSTREAM OF THE WORK AREA. ALL PERMANENT ADVANCE WARNING SIGNS SHALL BE GROUND MOUNTED ON TWO NON-R-350 OR MASH APPROVED BREAKAWAY POSTS AND SHALL BE MOUNTED IN COMPLIANCE WITH THE DELAWARE MUTCD. PERMANENT ADVANCE WARNING SIGNS SHALL BE MOUNTED AT A HEIGHT OF 7 FEET, MEASURED FROM THE ROADWAY TO THE BOTTOM OF THE SIGN. THE USE OF SKID MOUNTED SIGN SUPPORTS IS NOT ALLOWED UNLESS THE CONTRACTOR CAN DEMONSTRATE THAT A UTILITY CONFLICT EXISTS, WHICH SHALL BE VERIFIED BY THE ENGINEER, OR CONCRETE MEDIANS PREVENT THE INSTALLATION OF THE PERMANENT ADVANCE WARNING SIGNS IN THE APPROPRIATE LOCATION.
- CONTRACTOR TO PROVIDE CERTIFICATION OF COMPLIANCE WITH NATIONAL COOPERATIVE HIGHWAY RESEARCH PROGRAM (NCHRP) REPORT 350 FOR TRAFFIC CONTROL DEVICES OR MANUAL FOR ASSESSING SAFETY HARDWARE (MASH).
- LOOP DETECTORS: ADVANCE NOTICE TO BE PROVIDED TO DELDOT FOR CONSTRUCTION IN THE AREAS OF LOOP DETECTORS AT SIGNALIZED INTERSECTIONS. E.S.N.G. AND ITS CONTRACTOR WILL COORDINATE WITH DELDOT FOR LOOP DETECTOR REPAIRS (DEDOT WILL MAKE REPAIRS, AND DELDOT WILL INVOICE E.S.N.G. FOR THE REPAIRS).
- CONTRACTOR SHALL IMMEDIATELY REPAIR ANY DAMAGED EXISTING DRAINAGE TRENCHES OR UNDERDRAINS ENCOUNTERED DURING CONSTRUCTION.
- CONTRACTOR SHALL PROVIDE SHORING TO PROTECT THE ROAD FOR ANY EXCAVATION WITHIN 2 FEET OF THE EDGE OF PAVEMENT, PER DELDOT STANDARDS AND SPECIFICATIONS.
- ALL STORM DRAIN PIPES AND STRUCTURES IMPACTED BY PIPELINE INSTALLATION ARE TO BE REMOVED AND REPLACED AT THE CONTRACTOR'S EXPENSE.
- CONTRACTOR SHALL SCHEDULE WITH UTILITY COMPANY TO SHORE/HOLD ALL EXISTING UTILITY POLES WITHIN 5 FEET OF PIPELINE TRENCHING AT CONTRACTORS EXPENSE.
- TEST STATIONS SHALL NOT BE SET IN DITCH LINES OR SLOPES.
- HOT MIX DRIVEWAYS SHALL BE RESTORED WITH 6" 6ABC AND 2" TYPE "C" HOT MIX OR MATCH EXISTING (WHICHEVER IS GREATER) AND SHALL TIE INTO EDGE OF SHOULDER OF ROADWAY IF PATCHING IS LESS THAN 6 FEET FROM JOINT.
- STONE DRIVEWAYS SHALL BE RESTORED WITH 6" 6ABC OR MATCH EXISTING (WHICHEVER IS GREATER).
- COMMERCIAL ENTRANCES SHALL BE DIRECTIONAL DRILLED OR AS SHOWN ON THE PLAN.

MAINTENANCE OF TRAFFIC / TEMPORARY TRAFFIC CONTROL PLAN - GENERAL NOTES

- ALL WORK SHALL BE PERFORMED IN A MANNER THAT WILL REASONABLY PROVIDE THE LEAST PRACTICABLE OBSTRUCTION TO ROAD USERS, INCLUDING VEHICULAR TRAFFIC, BICYCLE TRAFFIC AND PEDESTRIAN TRAFFIC.
- ALL TEMPORARY TRAFFIC CONTROL AND TEMPORARY TRAFFIC CONTROL DEVICES SHALL BE IN ACCORDANCE WITH THE CONTRACT DOCUMENTS, THE LATEST EDITION OF THE MANUAL TITLED "STATE OF DELAWARE MANUAL ON UNIFORM TRAFFIC CONTROL DEVICES (MUTCD)" (HEREINAFTER REFERRED TO AS THE "DELAWARE MUTCD"), CURRENT STATE OF DELAWARE DEPARTMENT OF TRANSPORTATION STANDARD SPECIFICATIONS FOR ROAD AND BRIDGE CONSTRUCTION AND SUPPLEMENTAL SPECIFICATIONS, INCLUDING ALL REVISIONS OF THE DATE OF THE PERMIT APPROVAL.
- THE DEPARTMENT RESERVES THE RIGHT TO STOP THE CONTRACTOR'S OPERATIONS, IF, IN THE OPINION OF THE DEPARTMENT'S REPRESENTATIVE, THE CONTRACTOR'S OPERATIONS ARE NOT IN COMPLIANCE WITH THE DELAWARE MUTCD, THE SPECIFICATIONS OR THE PLANS OR IF THE CONTRACTOR'S OPERATIONS ARE DEEMED UNSAFE.
- IF THE CONTRACTOR DESIRES TO DEVIATE FROM THE TEMPORARY TRAFFIC CONTROL PLAN (TTCP) PROVIDED IN THE PLAN SET OR DESIRES CHANGES TO THE PHASING OR SCOPE OF THE TTCP, THE CONTRACTOR SHALL SUBMIT A NEW TTCP TO THE DISTRICT SAFETY OFFICER FOR APPROVAL PRIOR TO THE START OF WORK AT EACH AND EVERY LOCATION. THE TTCP SHALL BE PREPARED, SIGNED AND SEALED BY A PROFESSIONAL ENGINEER REGISTERED IN THE STATE OF DELAWARE AND SHALL BE PREPARED IN ACCORDANCE WITH ALL APPLICABLE DELDOT STANDARDS. THE TTCP SHALL BE SUBMITTED 14 CALENDAR DAYS IN ADVANCE OF STARTING WORK.
- ALL ROADWAY CLOSURES OR LANE CLOSURES BEYOND THOSE SPECIFIED AND APPROVED IN THE PLANS SHALL BE APPROVED BY THE DISTRICT SAFETY OFFICER A MINIMUM OF TWO WEEKS IN ADVANCE OF THE PROPOSED RESTRICTION.
- TEMPORARY TRAFFIC CONTROL DEVICES SHALL BE MAINTAINED IN GOOD CONDITION IN ACCORDANCE WITH THE BROCHURE ENTITLED "QUALITY GUIDELINES FOR TEMPORARY TRAFFIC CONTROL DEVICES", PUBLISHED BY THE AMERICAN TRAFFIC SAFETY SERVICES ASSOCIATION (ATSSA). ANY TEMPORARY TRAFFIC CONTROL DEVICES THAT DO NOT MEET THE QUALITY GUIDELINES SHALL BE REMOVED AND REPLACED WITH ACCEPTABLE DEVICES. FAILURE TO COMPLY WILL RESULT IN WORK STOPPAGE.
- TEMPORARY TRAFFIC CONTROL DEVICES USED ON ALL ROADWAYS OPEN TO THE PUBLIC IN DELAWARE SHALL CONFORM TO THE DELAWARE MUTCD AND SHALL BE IN NEW OR REFRISHED CONDITION. ALL DEVICES SHALL BE CRASHWORTHY IN ACCORDANCE WITH THE NATIONAL COOPERATIVE HIGHWAY RESEARCH PROGRAM (NCHRP) REPORT 350 AND/OR IN ACCORDANCE WITH THE LATEST EDITION OF THE MANUAL FOR ASSESSING SAFETY HARDWARE (MASH) PUBLISHED BY THE AMERICAN ASSOCIATION OF STATE HIGHWAY AND TRANSPORTATION OFFICIALS (AASHTO). THE CONTRACTOR SHALL SUBMIT CERTIFICATION FOR ALL TEMPORARY TRAFFIC CONTROL DEVICES USED SPECIFICALLY ON THIS PROJECT TO THE DISTRICT SAFETY OFFICER AT OR PRIOR TO THE PRE-CONSTRUCTION MEETING. THE CONTRACTOR SHALL NOT BEGIN WORK OR PLACE ANY TEMPORARY TRAFFIC CONTROL DEVICES UNTIL THE CERTIFICATION OF DEVICES HAS BEEN APPROVED BY THE DISTRICT SAFETY OFFICER.
- ANY DEFICIENCIES RELATED TO TEMPORARY TRAFFIC CONTROL THAT ARE REPORTED TO THE CONTRACTOR IN WRITING SHALL BE CORRECTED WITHIN 24 HOURS OR AS DIRECTED BY THE DISTRICT SAFETY OFFICER. CORRECTIVE ACTIONS ON SEVERE DEFICIENCIES SHALL BE TAKEN IMMEDIATELY. FAILURE TO COMPLY WILL RESULT IN THE SUSPENSION OF WORK UNTIL DEVICES ARE BROUGHT BACK INTO COMPLIANCE.
- ACCESS TO ALL BUSINESSES AND RESIDENCES WITHIN THE PROJECT LIMITS SHALL BE MAINTAINED THROUGHOUT THE DURATION OF THIS CONTRACT. ANY TEMPORARY CLOSURE OF A DRIVEWAY OR ENTRANCE FOR TIE-IN PURPOSES SHALL BE COORDINATED WITH THE ENGINEER AND THE PROPERTY OWNER IN ADVANCE OF THE CLOSURE.
- ACCESS TO ALL TRANSIT STOPS LOCATED WITHIN THE PROJECT LIMITS SHALL BE MAINTAINED UNLESS OTHERWISE DIRECTED BY THE PLANS OR THE ENGINEER. MAINTAINING ACCESS TO THE TRANSIT STOP SHALL INCLUDE MAINTAINING AN AREA FOR THE TRANSIT VEHICLE TO STOP TO PICK-UP AND DISCHARGE PASSENGERS AND ALSO AN ACCESSIBLE PATH FOR PEDESTRIANS TO SAFELY ACCESS THE TRANSIT STOP.
- THE CONTRACTOR SHALL PROVIDE ALL PROPERTY OWNERS AND RESIDENTS WHO LIVE ADJACENT TO THE WORK ZONE WITH WRITTEN NOTICE, 48 HOURS IN ADVANCE OF THE START OF CONSTRUCTION WORK. THIS NOTIFICATION SHALL INCLUDE THE SCOPE OF WORK, WORKING HOURS, ANTICIPATED START AND COMPLETION DATES, A SUMMARY OF CONSTRUCTION ACTIVITIES WHICH MAY INTERFERE WITH ACCESS TO THE PROPERTY INCLUDING A SCHEDULE AND ACCESS COORDINATION PLAN, CONTRACTOR'S NAME AND ADDRESS AND A DELDOT CONTACT PHONE NUMBER. FAILURE TO GIVE PROPER NOTICE WILL RESULT IN A SUSPENSION OF THE WORK, UNTIL PROPER NOTICE IS PROVIDED. THE CONTRACTOR SHALL PROVIDE WRITTEN VERIFICATION TO THE ENGINEER THAT THE PROPERTY OWNERS AND RESIDENTS WERE NOTIFIED.
- THE CONTRACTOR SHALL BE RESPONSIBLE FOR NOTIFYING THE LOCAL 911 CENTER, LOCAL SCHOOLS AND THE DELDOT PUBLIC INFORMATION CENTER OF ALL ROADS AND LANES TO BE CLOSED A MINIMUM OF SEVEN CALENDAR DAYS BEFORE THE CLOSURE.
- THE CONTRACTOR SHALL NOTIFY THE LOCAL 911 CENTER IF ACCESS TO A FIRE HYDRANT IS TEMPORARILY RESTRICTED.
- THE CONTRACTOR SHALL BE RESPONSIBLE FOR ENSURING THAT THE TRANSPORTATION MANAGEMENT CENTER IS NOTIFIED EACH AND EVERY DAY WHEN WORK IS BEING PERFORMED IN STATE RIGHT-OF-WAY. THE CONTRACTOR SHALL IDENTIFY THE TYPE OF WORK, ANY LANE(S) OR SHOULDERS CLOSED, THE LENGTH OF TIME FOR WORK, WHEN THE LANE RESTRICTIONS ARE IN PLACE AND WHEN LANE RESTRICTIONS ARE LIFTED, CONTACT PERSON/PHONE NUMBER AND STATE INSPECTOR, THE TRANSPORTATION MANAGEMENT CENTER CAN BE REACHED AT (302) 659-4600.
- AT THE END OF EACH WORKDAY, THE CONTRACTOR SHALL CORRECT ALL VERTICAL DIFFERENCES IN ACCORDANCE WITH TABLE 66-1 OF THE DELAWARE MUTCD.
- AT THE END OF EACH DAY'S OPERATION AND BEFORE TRAFFIC IS RETURNED TO UNRESTRICTED ROADWAY USE, TEMPORARY PAVEMENT MARKINGS SHALL BE APPLIED IN ACCORDANCE WITH THE DELAWARE MUTCD AND DELDOT'S TEMPORARY PAVEMENT MARKINGS POLICY.
- WHEN SIDE ROADS INTERSECT THE WORK ZONE, ADDITIONAL TRAFFIC CONTROL DEVICES SHALL BE ERECTED INCLUDING ADVANCED WARNING SIGNS.
- ALL STORAGE OF EQUIPMENT AND MATERIAL SHALL COMPLY WITH SECTION 66.2) OF THE DELAWARE MUTCD.
- ALL FLAGGERS SHALL COMPLY WITH CHAPTER 6E OF THE DELAWARE MUTCD AND MUST BE AMERICAN TRAFFIC SAFETY SERVICES ASSOCIATION (ATSSA) CERTIFIED IN THE STATE OF DELAWARE.
- THE CONTRACTOR SHALL BE RESPONSIBLE FOR COORDINATING HIS/HER WORK WITH OTHER CONTRACTORS IN THE AREA.
- ALL PAVEMENT MARKINGS THAT ARE NO LONGER IN USE AND CONFLICT WITH TEMPORARY PAVEMENT MARKINGS SHALL BE REMOVED AND COMPLETELY OBLITERATED BY A METHOD APPROVED BY THE ENGINEER. PAINTINGS OVER THE CONFLICTING PAVEMENT MARKINGS WILL NOT BE ACCEPTED AS A METHOD OF REMOVAL.
- THE CONTRACTOR IS RESPONSIBLE FOR THE MAINTENANCE OF EXISTING PAVEMENT WITHIN THE PROJECT LIMITS FOR THE DURATION OF THE CONTRACT OR AS DIRECTED BY THE ENGINEER.
- ALL ROADWAYS AND ENTRANCES NOT OPEN TO TRAFFIC SHALL BE CLOSED USING TYPE III BARRICADES AND SHALL BE INSTALLED PER THE DELAWARE MUTCD. IF THE ROADWAY OR ENTRANCE IS CLOSED FOR MORE THAN ONE MONTH, THE CONTRACTOR SHALL ERECT PERMANENT BARRICADES AS DIRECTED IN PART 3 OF THE DELAWARE MUTCD.
- ALL ROADS LEADING INTO THE WORK ZONE SHALL HAVE "UTILITY WORK AHEAD" AND "END UTILITY WORK" SIGNS.
- STABILIZED CONSTRUCTION ENTRANCES SHALL BE USED TO REDUCE OFF-SITE SEDIMENTATION BY ELIMINATING THE TRACKING OF EXCESS SOIL ONTO PAVED PUBLIC ROADWAYS. ALL ROADWAYS SHALL BE KEPT CLEAN OF SEDIMENT AND DEBRIS. THE CONTRACTOR SHALL UTILIZE A STREET SWEeper TO MINIMIZE DUST AND SOIL ON ROADWAYS AND ACCESS LOCATIONS SHALL BE SWEEPED ONCE EACH DAY AS A MINIMUM.
- INDIVIDUAL CONSTRUCTION ENTRANCE LOCATIONS SHALL BE KEPT TO A MINIMUM AND DETERMINED IN THE FIELD BY THE CONTRACTOR. DELDOT SHALL BE NOTIFIED OF ALL LOCATIONS PRIOR TO INSTALLATION.
- AS AN ADVANCE WARNING, THE TRUCK SYMBOL (W-10) SIGN SHALL BE INSTALLED IN EITHER APPROACH DIRECTION FOR EACH STABILIZED CONSTRUCTION ENTRANCE AND REMAIN IN PLACE FOR THE DURATION OF THE DRIVEWAY USE. CONSTRUCTION WARNING SIGNS SHALL BE BLACK LEGEND ON ORANGE BACKGROUND AND WHEN UTILIZED FOR EXTENDED DURATIONS SHALL BE INSTALLED ON BREAKAWAY POSTS PER DELDOT STANDARD CONSTRUCTION DETAIL T-5.
- WORK WITHIN A SIGNALIZED INTERSECTION OR IMPACT TO A SIGNALIZED INTERSECTION SHALL FOLLOW THE DELDOT MUTCD, TEMPORARY TRAFFIC CONTROL INTERIM GUIDANCE "TRAFFIC CONTROL WITHIN INTERSECTIONS", AND WILL REQUIRE A UNIFORMED TRAFFIC OFFICER.
- THE DEPARTMENT RESERVES THE RIGHT TO RESTRICT LANE/SHOULDER CLOSURES IN CASE A SPECIAL EVENT IS SCHEDULED TO CROSS OR PROCEED THROUGH A WORK ZONE. IF SUCH A RESTRICTION IS DEEMED NECESSARY, THE DEPARTMENT SHALL PROVIDE THE PERMIT HOLDER A MINIMUM 2 WEEK ADVANCE NOTIFICATION.
- ALL STABILIZED CONSTRUCTION ENTRANCE LOCATIONS SHALL BE APPROVED BY DELDOT PRIOR TO INSTALLATION.
- CONTRACTOR SHALL UTILIZE THE FOLLOWING TRAFFIC CONTROL FROM THE DELAWARE MUTCD MOST CURRENT ADDITION.
 - A. TYPICAL APPLICATION 5, FIGURE 6H-5-SHOULDER CLOSURE ON AN INTERSTATE, FREEWAY, OR EXPRESSWAY WITH A TEMPORARY TRAFFIC BARRIER
- MESSAGE BOARDS ARE REQUIRED 10 DAYS IN ADVANCE OF CONSTRUCTION.

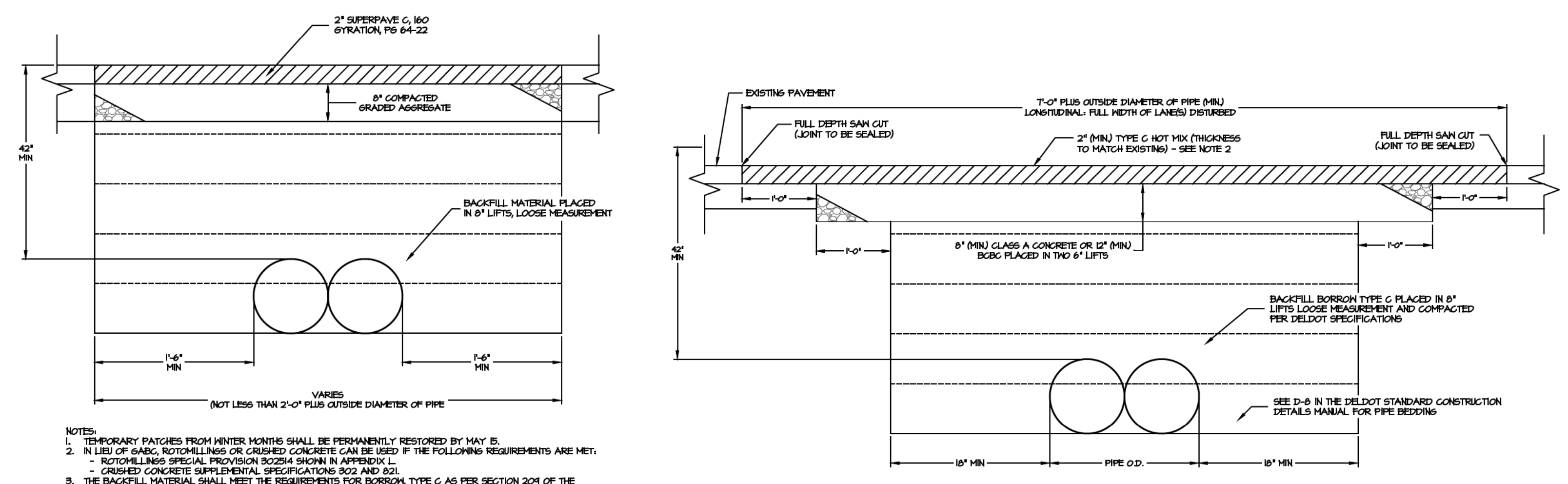

- NOTES:**
- TEMPORARY PATCHES FROM WINTER MONTHS SHALL BE PERMANENTLY RESTORED BY MAY 15.
 - IN LIEU OF 6ABC, ROTOMILLING OR CRUSHED CONCRETE CAN BE USED IF THE FOLLOWING REQUIREMENTS ARE MET:
 - ROTOMILLING SPECIAL PROVISION 20204 SHOWN IN APPENDIX L.
 - CRUSHED CONCRETE SUPPLEMENTAL SPECIFICATIONS 802 AND 621.
 - THE BACKFILL MATERIAL SHALL MEET THE REQUIREMENTS FOR BORROW TYPE C AS PER SECTION 204 OF THE STANDARD SPECIFICATIONS.
 - COMPACTION SHALL MEET THE REQUIREMENTS AS PER SECTION 204 OF THE STANDARD SPECIFICATIONS.
 - FLOWABLE FILL IS ALLOWABLE AS A BACKFILL MATERIAL. FLOWABLE FILL SHALL MEET THE REQUIREMENTS OF SPECIAL PROVISION 202040 AS SHOWN IN APPENDIX F.
 - ALL MATERIALS AND METHODS OF CONSTRUCTION SHALL MEET THE REQUIREMENTS SET FORTH IN THE CURRENT DELAWARE DEPARTMENT OF TRANSPORTATION STANDARD SPECIFICATIONS FOR ROAD AND BRIDGE CONSTRUCTION.

- NOTES:**
- PATCH WIDTHS ARE MEASURED ALONG THE ROADWAY CENTERLINE AND SHALL BE THE FULL WIDTH OF THE LANE OR LANES DISTURBED.
 - THIS IS A MINOR PATCH. IF THE EXISTING ROADWAY HAS A HEAVIER CROSS SECTION THAN SHOWN HERE, IT WILL BE REPLACED WITH THAT CROSS SECTION OR AS DIRECTED BY THE ENGINEER.

TEMPORARY PATCH

(SOURCE: DELDOT UTILITIES MANUAL - FIGURE 2-8)
MINIMUM DESIGN REQUIREMENTS
DISTRICT ENGINEER MAY CHANGE REQUIREMENTS IN SPECIAL CASES

PERMANENT PATCH

(SOURCE: DELDOT STANDARD CONSTRUCTION DETAIL SHEET NO. P-4)



REVISIONS			
NO.	DATE	DESCRIPTION	BY



MORRIS & RITCHIE ASSOCIATES, INC.
ENGINEERS, PLANNERS, SURVEYORS AND LANDSCAPE ARCHITECTS
111 RUTHAR DRIVE
NEWARK, DE 19711
(302) 326-2200
MRA@GTA.COM
© 2020 MORRIS & RITCHIE ASSOCIATES, INC.

EASTERN SHORE
NATURAL GAS
500 ENERGY LANE, SUITE 200 DOVER, DE 19901
TELEPHONE (302) 734-6710 - FAX (302) 734-6745

TRAFFIC CONTROL DETAILS

**6" PROPOSED PIPELINE
CAMDEN CONTROLLER
KENT COUNTY, DE**

ESNG PROJECT CODE:	DATE:	6/19/2026
MRA PROJECT NO:	SCALE:	N/A
DESIGN/CHECK BY:	JTH/CWB	SHEET: 6 OF 18

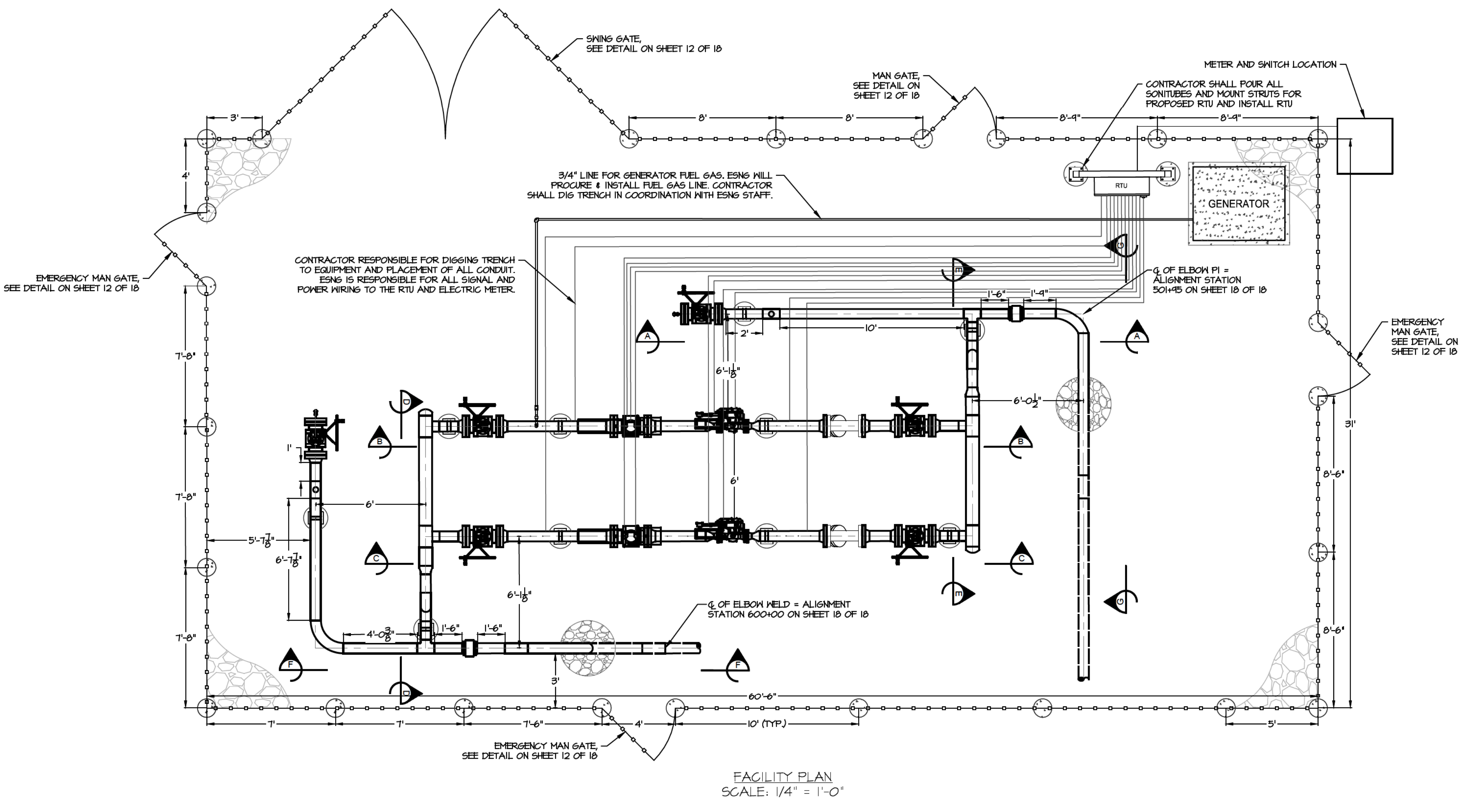
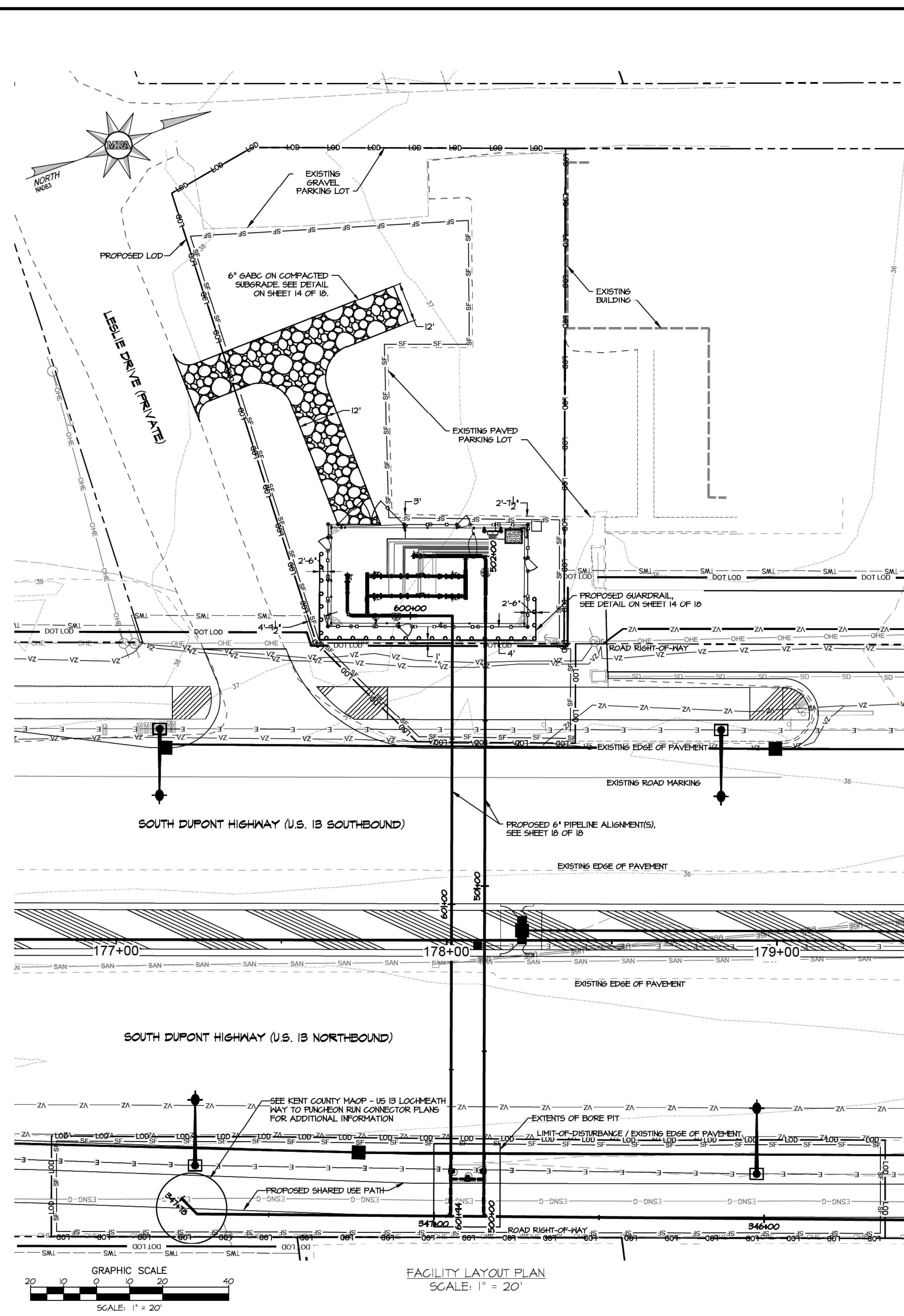

- NOTE:
- CONTRACTOR SHALL VERIFY VERTICAL AND HORIZONTAL LOCATIONS OF ALL EXISTING FACILITIES PRIOR TO TIE-IN FABRICATION.
 - EXCAVATE WITH CAUTION!!! EXACT LOCATION OF EXISTING UNDERGROUND PIPES & UTILITIES IS UNKNOWN.
 - CONTRACTOR TO FIELD VERIFY ALL DIMENSIONS PRIOR TO FABRICATION.

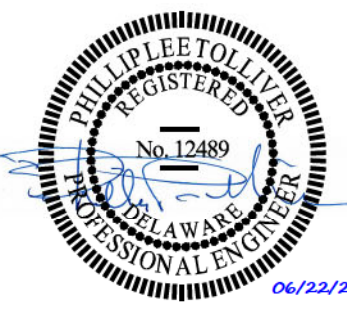

REVISIONS			
NO.	DATE	DESCRIPTION	BY

MRA
MORRIS & RITCHIE ASSOCIATES, INC.
 ENGINEERS, PLANNERS, SURVEYORS AND LANDSCAPE ARCHITECTS
 111 RUTHAR DRIVE
 NEWARK, DE 19711
 (302) 326-2200
 MRAGTA.COM
 © 2025 MORRIS & RITCHIE ASSOCIATES, INC.

EASTERN SHORE
 NATURAL GAS
 500 ENERGY LANE, SUITE 200 DOVER, DE 19901
 TELEPHONE (302) 734-6710 - FAX (302) 734-6745

CAMDEN CONTROLLER FACILITY SITE LAYOUT & PLAN

6" PROPOSED PIPELINE CAMDEN CONTROLLER KENT COUNTY, DE

ESNG PROJECT CODE: ES XXXX	DATE: 6/19/2026
MRA PROJECT NO: 23098	SCALE: AS SHOWN
DESIGN/CHECK BY: JTH/CWB	SHEET: 7 OF 18

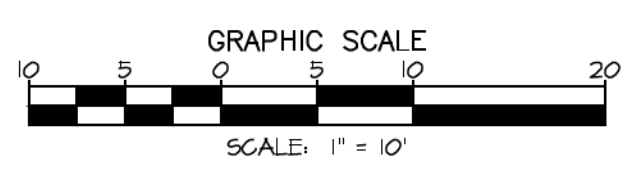
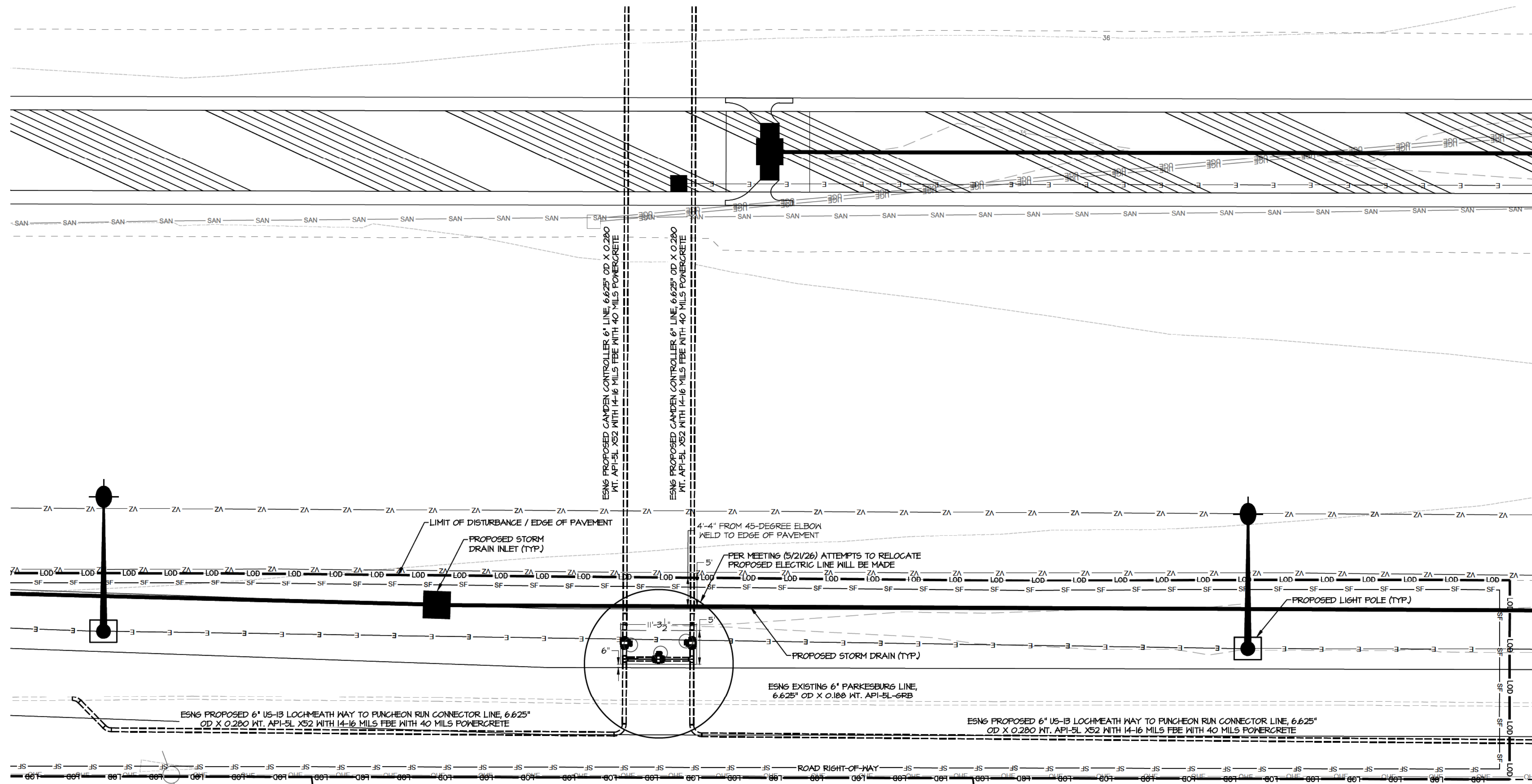

EASTERN TIE-IN PLAN
SCALE: 1" = 10'

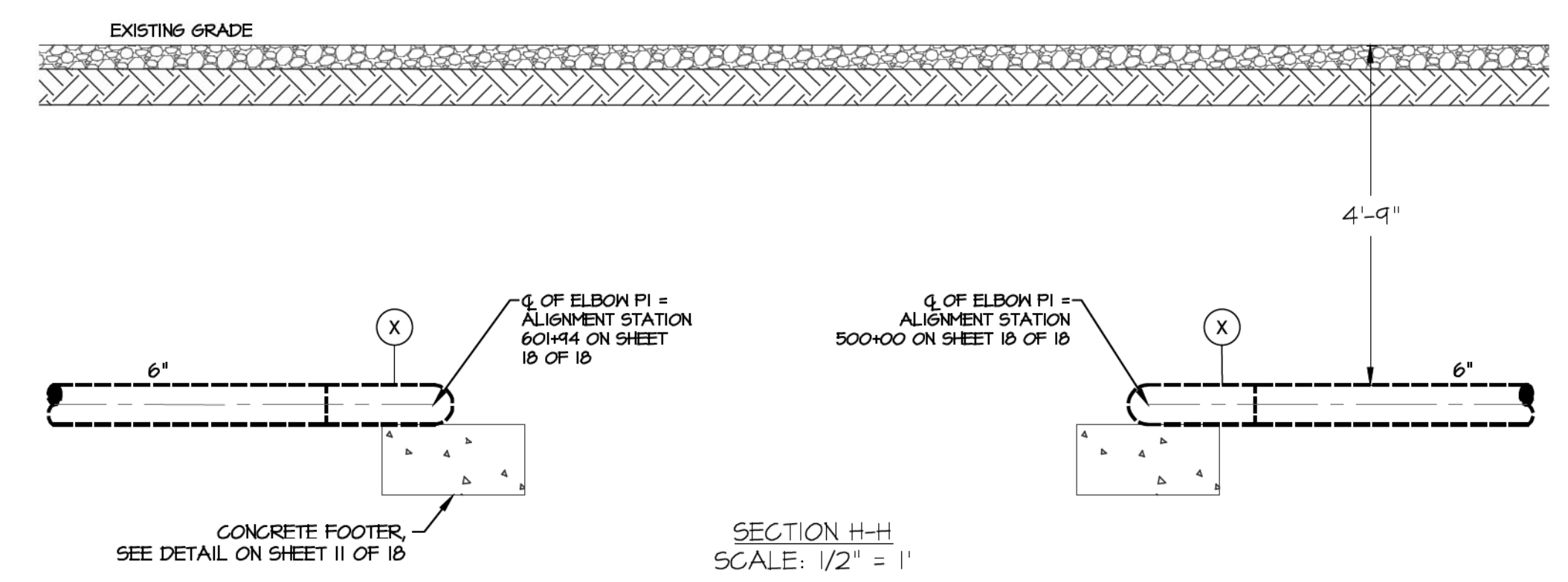

SECTION H-H
SCALE: 1/2" = 1'

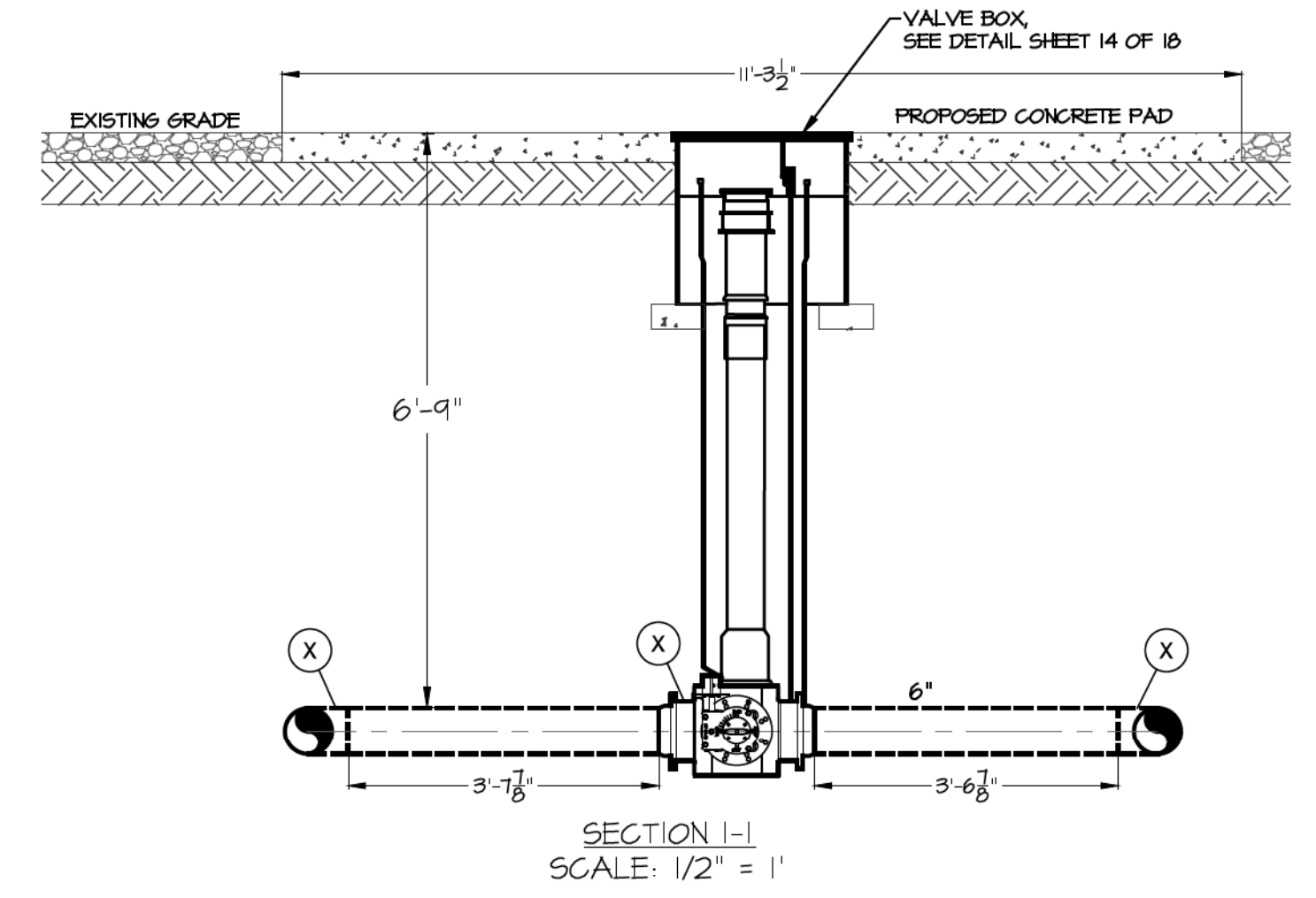

SECTION I-I
SCALE: 1/2" = 1'

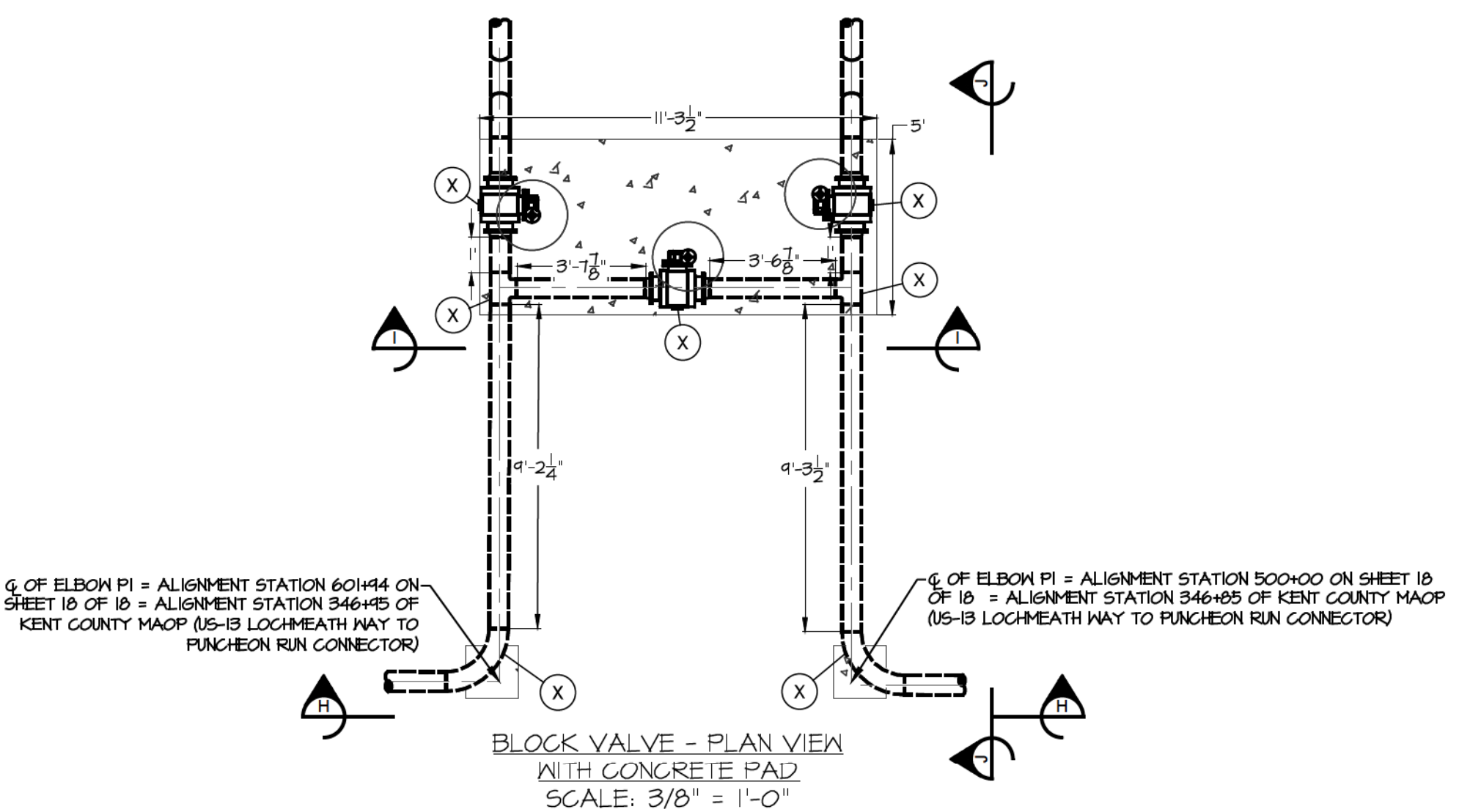

BLOCK VALVE - PLAN VIEW
WITH CONCRETE PAD
SCALE: 3/8" = 1'-0"

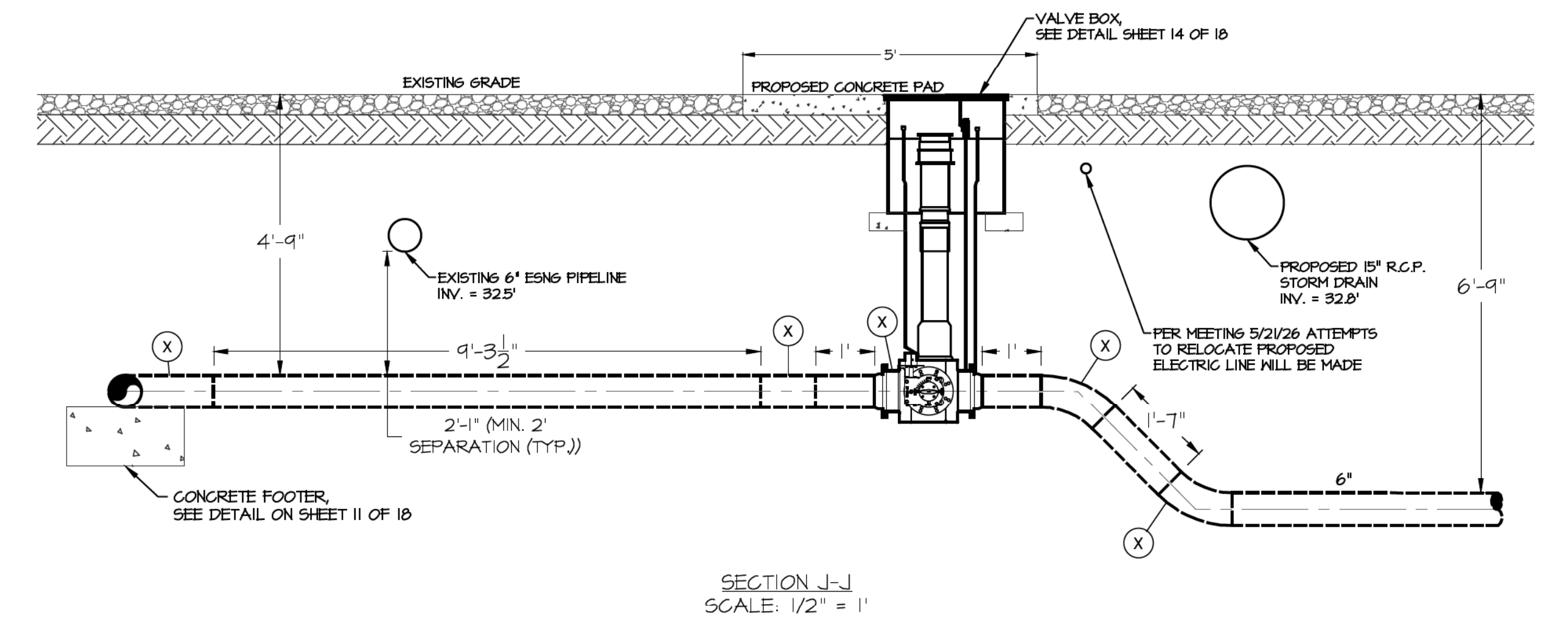

SECTION J-J
SCALE: 1/2" = 1'

VALVE BOX NOTE:
1. CONTRACTOR SHALL COORDINATE WITH EASTERN SHORE AND DELDOT REPRESENTATIVES FOR VALVE BOX INSTALLATION. DELDOT'S CONTRACTOR IS PROPOSING TO PERFORM GRADING WORK IN THIS AREA WHICH MAY REQUIRE ADJUSTMENTS TO THE VALVE BOX ELEVATIONS IN THE FUTURE.

- NOTE:
- CONTRACTOR SHALL VERIFY VERTICAL AND HORIZONTAL LOCATIONS OF ALL EXISTING FACILITIES PRIOR TO TIE-IN FABRICATION.
 - EXCAVATE WITH CAUTION!!! EXACT LOCATION OF EXISTING UNDERGROUND PIPES & UTILITIES IS UNKNOWN.
 - CONTRACTOR TO FIELD VERIFY ALL DIMENSIONS PRIOR TO FABRICATION.



REVISIONS			
NO.	DATE	DESCRIPTION	BY

MRA
MORRIS & RITCHIE ASSOCIATES, INC.
ENGINEERS, PLANNERS, SURVEYORS AND
LANDSCAPE ARCHITECTS
111 RUTHAR DRIVE
NEWARK, DE 19711
(302) 326-2200
MRA@TA.COM
© 2025 MORRIS & RITCHIE ASSOCIATES, INC.

EASTERN SHORE
NATURAL GAS
500 ENERGY LANE, SUITE 200 DOVER, DE 19901
TELEPHONE (302) 734-6710 • FAX (302) 734-6745

**CAMDEN CONTROLLER
EASTERN TIE-IN PLAN**

**6" PROPOSED PIPELINE
CAMDEN CONTROLLER
KENT COUNTY, DE**

ESNG PROJECT CODE: ES XXXX	DATE: 6/19/2026
MRA PROJECT NO: 23098	SCALE: AS SHOWN
DESIGN/CHECK BY: JTH/CWB	SHEET: 9 OF 18

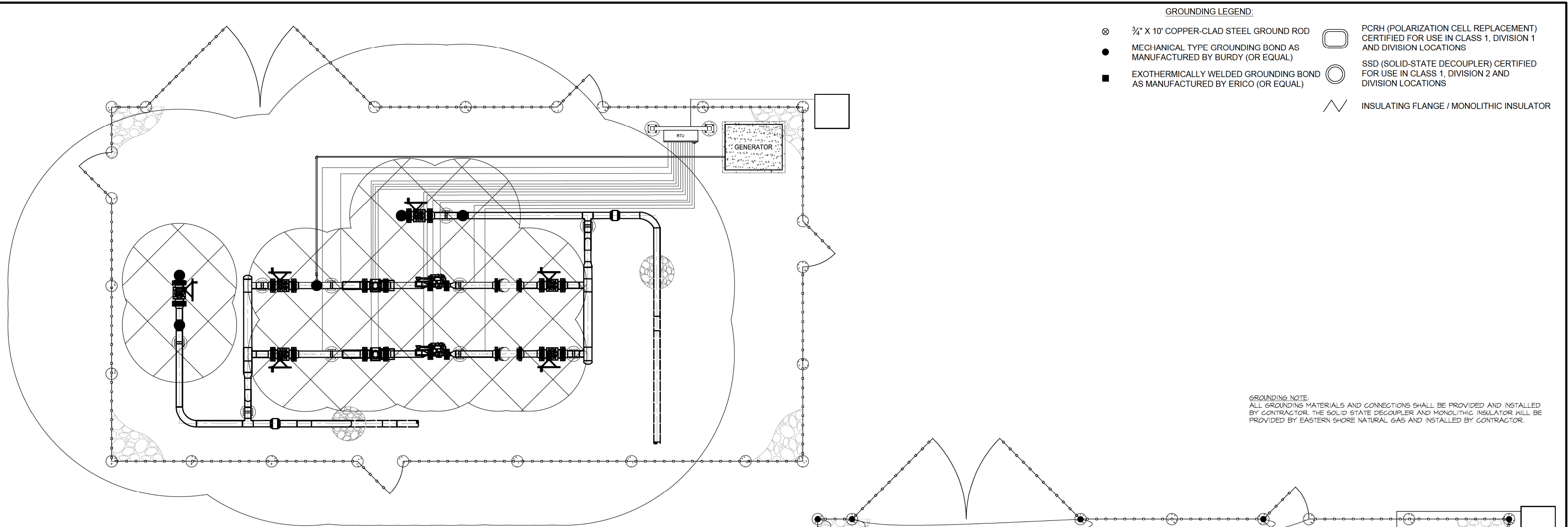

FACILITY SITE HAZARD CLASSIFICATION PLAN
SCALE: 1/4" = 1'-0"

HAZARD CLASSIFICATION LEGEND:

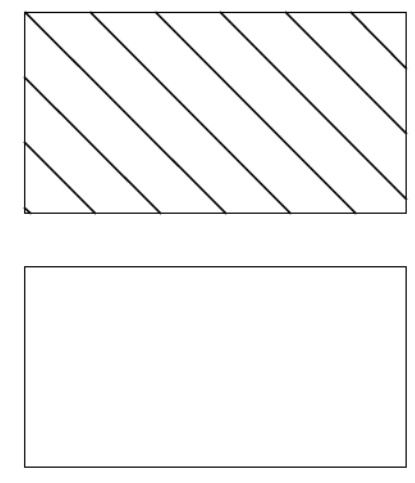

CLASS 1, DIVISION 1

CLASS 1, DIVISION 2

- ● PROCESS EQUIPMENT VENT
- ▲ ▲ INSTRUMENT/CONTROL DEVICE VENT
- ■ RELIEF VALVE VENT
- ■ FLANGED CONNECTION
- □ TYPICAL MANUAL VALVE, CHECK VALVE OR METER
- ▲ ▲ VALVE OPERATORS USING FLAMMABLE POWER GAS

HAZARD CLASSIFICATION NOTES:

1. THIS DRAWING APPLIES TO THE CLASSIFICATION OF LOCATIONS FOR TEMPORARY AND PERMANENTLY INSTALLED ELECTRICAL EQUIPMENT.
2. ELECTRICAL HAZARDOUS AREA CLASSIFICATIONS ARE BASED ON NFPA 70 NATIONAL ELECTRIC CODE.
3. UNLESS OTHERWISE NOTED, DETAILS APPLY TO BOTH FLAMMABLE LIQUIDS AND FLAMMABLE GAS THAT IS LIGHTER THAN AIR.

GROUNDING LEGEND:

- ⊗ 3/4" X 10' COPPER-CLAD STEEL GROUND ROD
- MECHANICAL TYPE GROUNDING BOND AS MANUFACTURED BY BURDY (OR EQUAL)
- EXOTHERMICALLY WELDED GROUNDING BOND AS MANUFACTURED BY ERICO (OR EQUAL)
- PCRH (POLARIZATION CELL REPLACEMENT) CERTIFIED FOR USE IN CLASS 1, DIVISION 1 AND DIVISION LOCATIONS
- SSD (SOLID-STATE DECOUPLER) CERTIFIED FOR USE IN CLASS 1, DIVISION 2 AND DIVISION LOCATIONS
- ∇ INSULATING FLANGE / MONOLITHIC INSULATOR

GROUNDING NOTE:
ALL GROUNDING MATERIALS AND CONNECTIONS SHALL BE PROVIDED AND INSTALLED BY CONTRACTOR. THE SOLID STATE DECOUPLER AND MONOLITHIC INSULATOR WILL BE PROVIDED BY EASTERN SHORE NATURAL GAS AND INSTALLED BY CONTRACTOR.

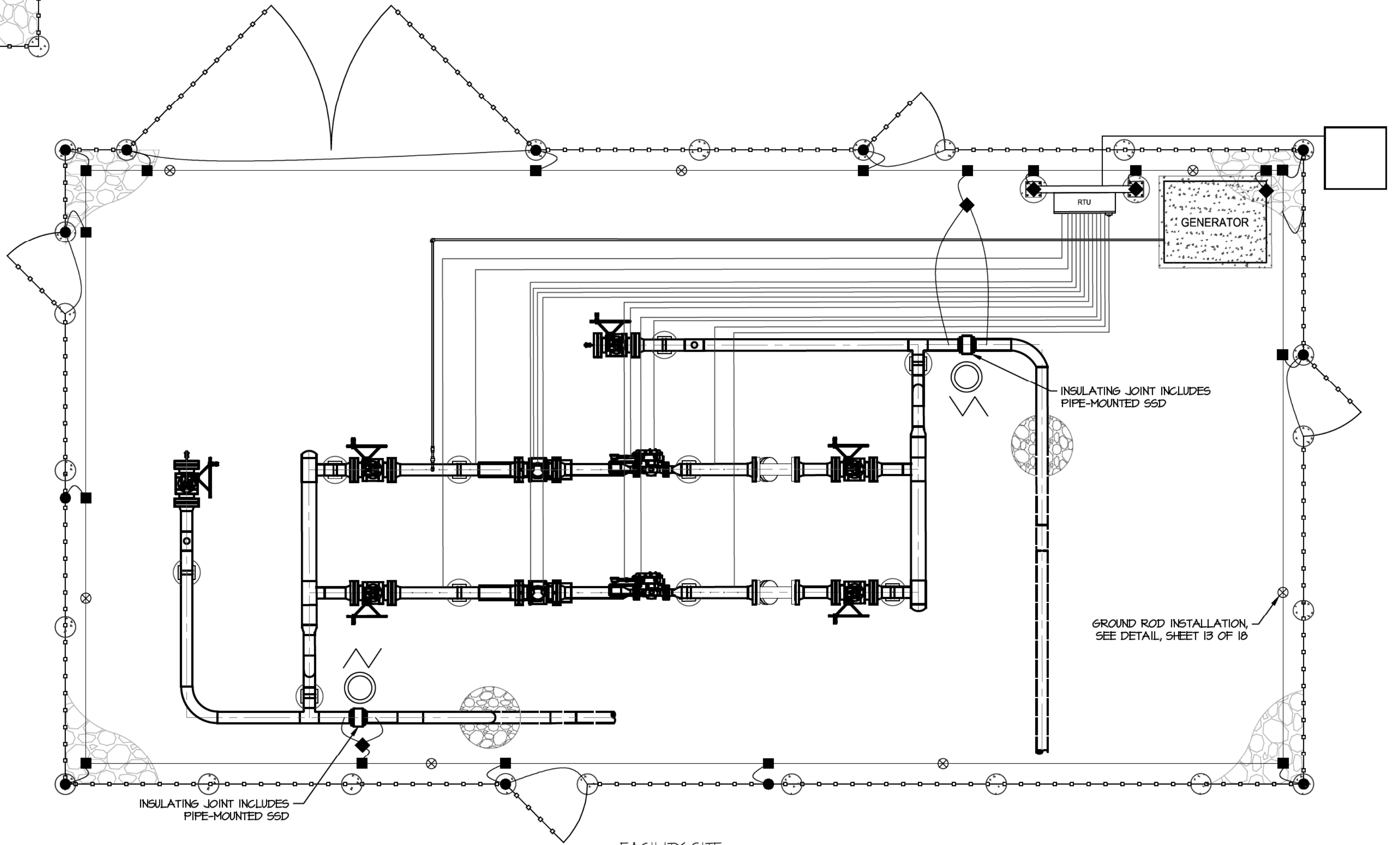

FACILITY SITE GROUNDING PLAN
SCALE: 1/4" = 1'-0"

CAMDEN CONTROLLER FACILITY
HAZARD CLASSIFICATION &
GROUNDING PLAN

6" PROPOSED PIPELINE
CAMDEN CONTROLLER
KENT COUNTY, DE

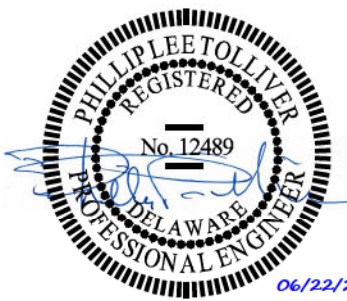

REVISIONS			
NO.	DATE	DESCRIPTION	BY



MORRIS & RITCHE ASSOCIATES, INC.
ENGINEERS, PLANNERS, SURVEYORS AND
LANDSCAPE ARCHITECTS
111 RUTHAR DRIVE
NEWARK, DE 19711
(302) 326-2200

MRAGTA.COM
© 2025 MORRIS & RITCHE ASSOCIATES, INC.



ESNG PROJECT CODE:	ES XXXX	DATE:	6/19/2026
MRA PROJECT NO:	23098	SCALE:	AS SHOWN
DESIGN/CHECK BY:	JTH/CWB	SHEET:	10 OF 18

RTU DETAIL LIST				
ITEM #	QUANTITY	UNITS	DESCRIPTION	PART #
01	30 FT	EA.	HOT-DIP GALVANIZED INSTALLATION GIRDERS WITH GREATER ADJUSTABILITY FOR HEAVY-DUTY APPLICATIONS	MI-903M
02	4	EA.	HOT-DIP GALVANIZED CONNECTOR FOR FASTENING MI GIRDERS PERPENDICULARLY TO ONE ANOTHER	MIC-90-L
03	2	EA.	HOT-DIP GALVANIZED BRACKET FOR CONNECTING TO CONCRETE	MIC-C90-D
04	10 FT	EA.	13/16" 12 GAGE STRUT	---
05	2	EA.	HOT-DIP GALVANIZED SCREW FOR EASIER FASTENING AND ONE-HANDED ADJUSTMENT OF MI AND MIQ CONNECTORS	MIA-OH90
06	4	EA.	3/8" STRUT	MQF
07	4	EA.	3/8" ZINC WASHER	---
08	4	EA.	3/8"-16 X 3/4" BOLTS	---
09	8	EA.	1/2" X 12" ANCHOR BOLTS	---
10	2	EA.	ALL THREAD WITH 4 EACH NUT AND WASHERS 3/8"-16	---
11	1	EA.	BATTERY BOX ENCLOSURE FOR OFF-GRID SOLAR - BBA - 2	BBA-2
12	2	EA.	U BOLTS	156433
13	2	EA.	GIRDER END CAP FOR SAFER AND NEATER COVERING TO MI AND MIQ GIRDER ENDS	MIA-EC90
14	4	EA.	CHANNEL END CAP STRUT END CAP MEK RED	MEK
15	1	EA.	MPLS ANTENNA CONNECTED TO EXTRA STRUT	---

INSIDE RTU DETAIL LIST				
ITEM #	QUANTITY	UNITS	DESCRIPTION	PART #
01	1	EA.	BACK PANEL FOR THE BACK CABINET FROM UNITED ELECTRIC	HFA48P36
02	4	EA.	MTL SURGE SUPPRESSOR FROM MTL	MTL32SD
03	1	EA.	EAGLE XARTU/1 FROM EAGLE	3243-64296-637F
04	1	EA.	SAMLEX POWER SUPPLY FROM TESCO	SEC2415UL
05A	1	EA.	WIRING DUCT, GRAY, 6 FT. LENGTH, 2.25" WIDTH, 0.30" SLOT WIDTH FROM TOMAS & BETTS	TYDX2WP66
05B	1	EA.	WIRING DUCT COVER, FOR USE WITH 2-1/4" WIRING DUCT FROM TOMAS & BETTS	TYDX2CP66
06	1	EA.	MOUNTING TRACK, 35 MM DIN RAIL TYPE FROM GRAINGER	18Z758
07	1	EA.	TERMINAL STRIP FOR POWER FROM UNITED OR HOME DEPOT	---
08	1	EA.	GROUND BAR KIT, 100 AMPS AC, FOR USE WITH Q0, HOMELINE, NQDD AND NF PANELBOARDS	PK9GTA
09	1	EA.	END CLAMP FOR TERMINAL BLOCKS FROM SCHNIDER ELECTRIC	NSYRAABV35
10	2	EA.	TERMINAL BLOCK FROM SCHNIDER ELECTRIC	NSYTRV22
11	1	EA.	A/C POWER LOSS RELAY FROM ALLIED	PLC-RSC-120UC/21EX-2909525

- VERIFY PIPE TEMPERATURE IS AT LEAST 5°F ABOVE THE DEW POINT BEFORE CLEANING OF PIPE.
- ABRASIVE BLAST PIPE UNTIL FREE OF RUST, DIRT, AND OTHER FOREIGN MATTER, PER MANUFACTURER SPECIFICATIONS.
- APPLY 2-PART EPOXY COATING, PER MANUFACTURER SPECIFICATIONS.
- ENSURE THAT 2-PART EPOXY COATING IS CLEANED PER MANUFACTURER SPECIFICATIONS, BEFORE APPLYING CUC ABOVEGROUND COATING SYSTEM.
- APPLY CUC ABOVEGROUND COATING SYSTEM, PER MANUFACTURER SPECIFICATIONS.

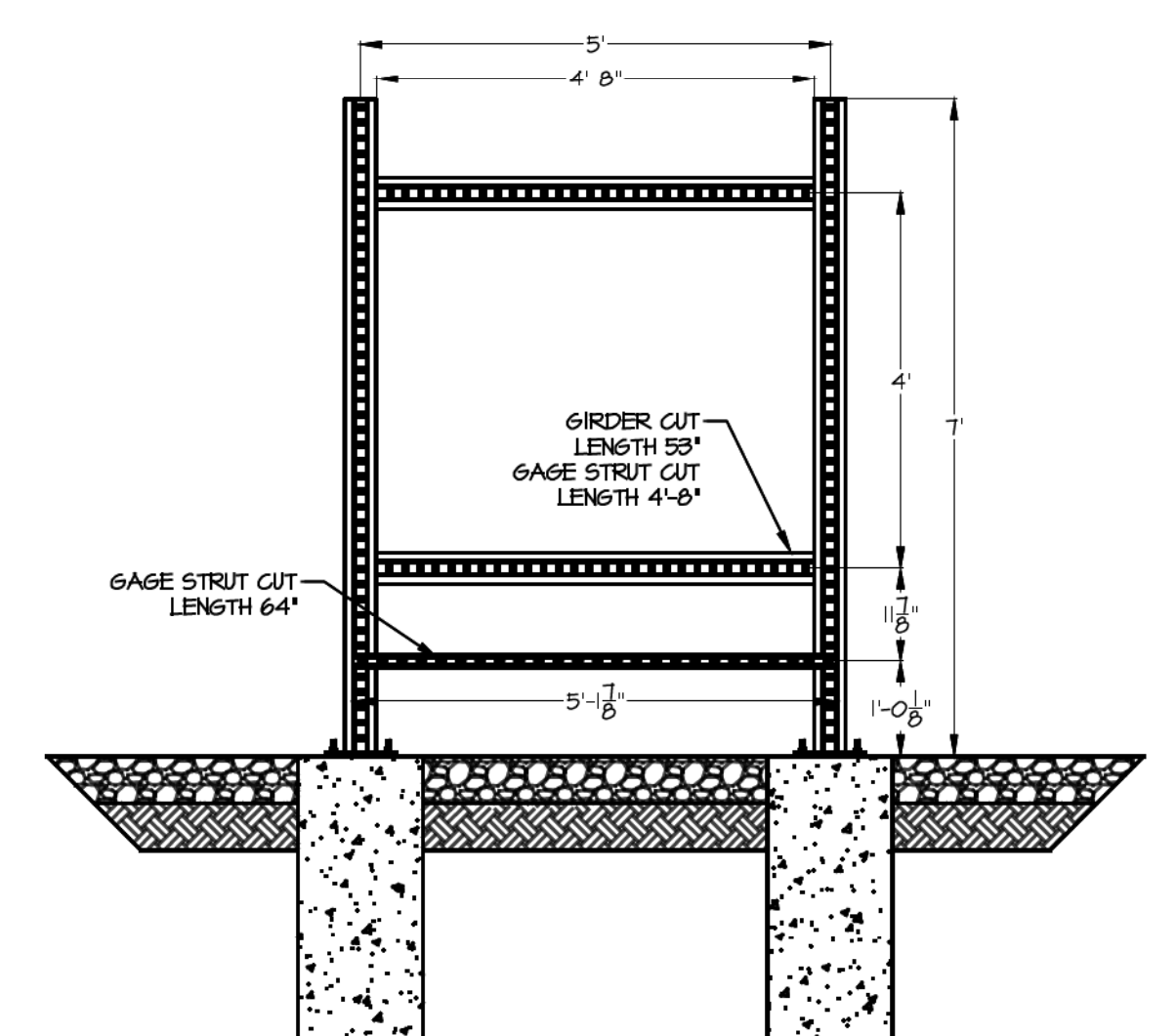
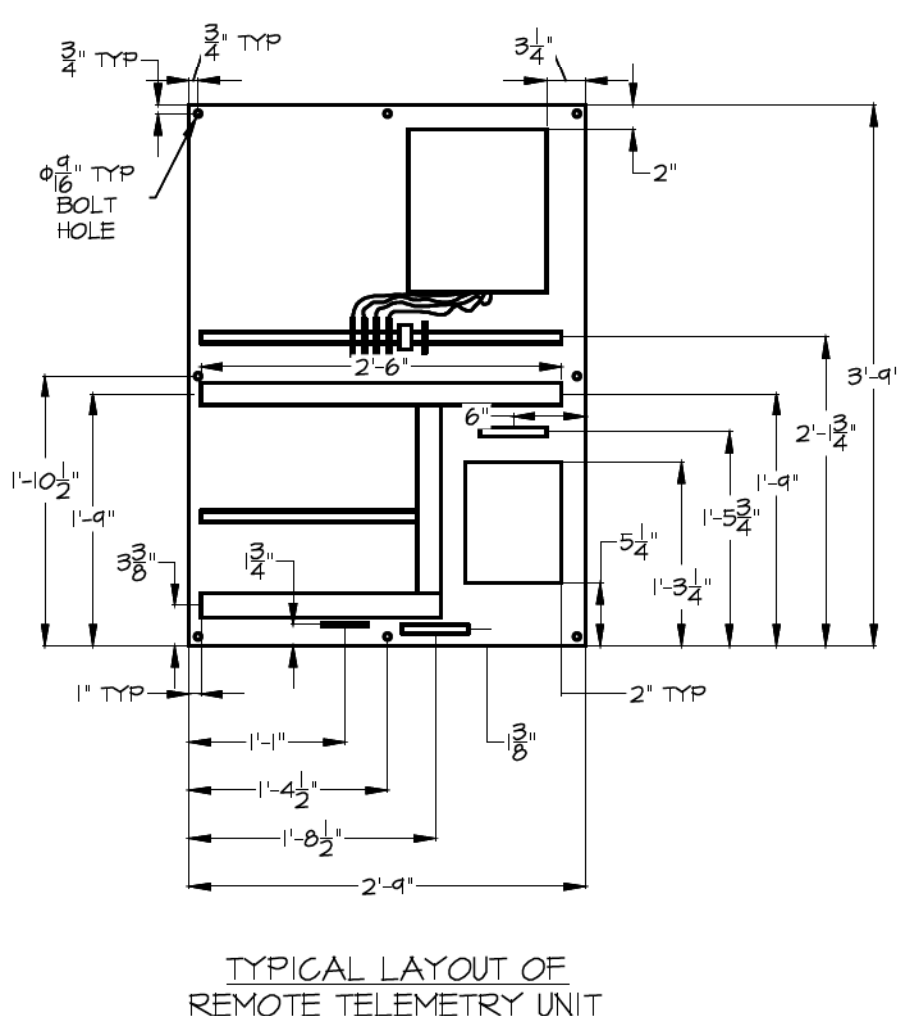
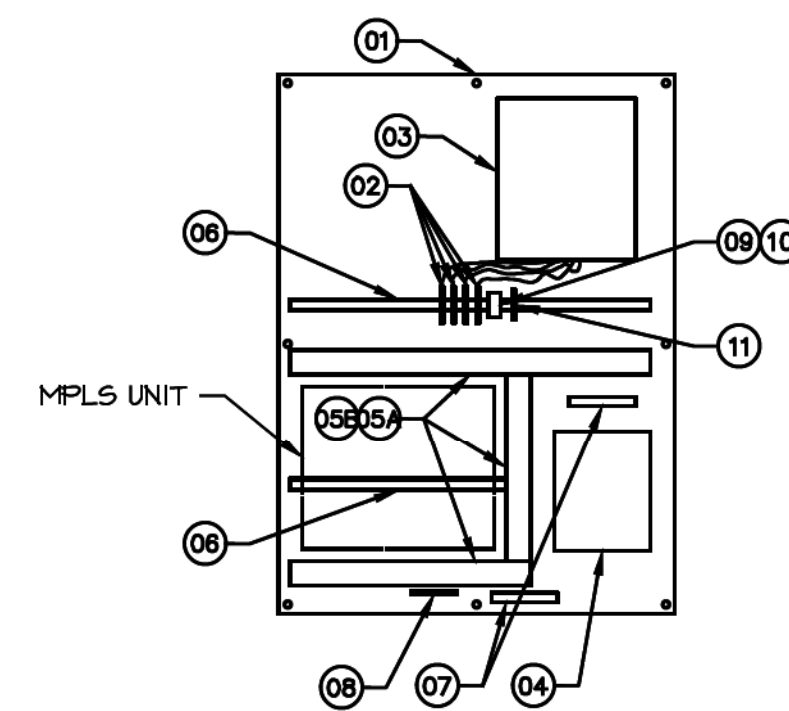
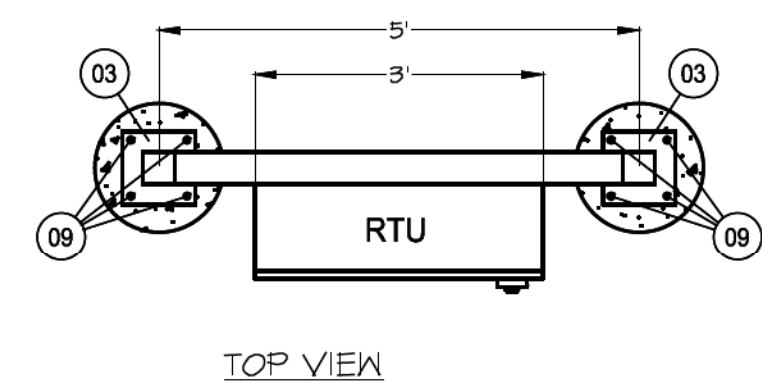
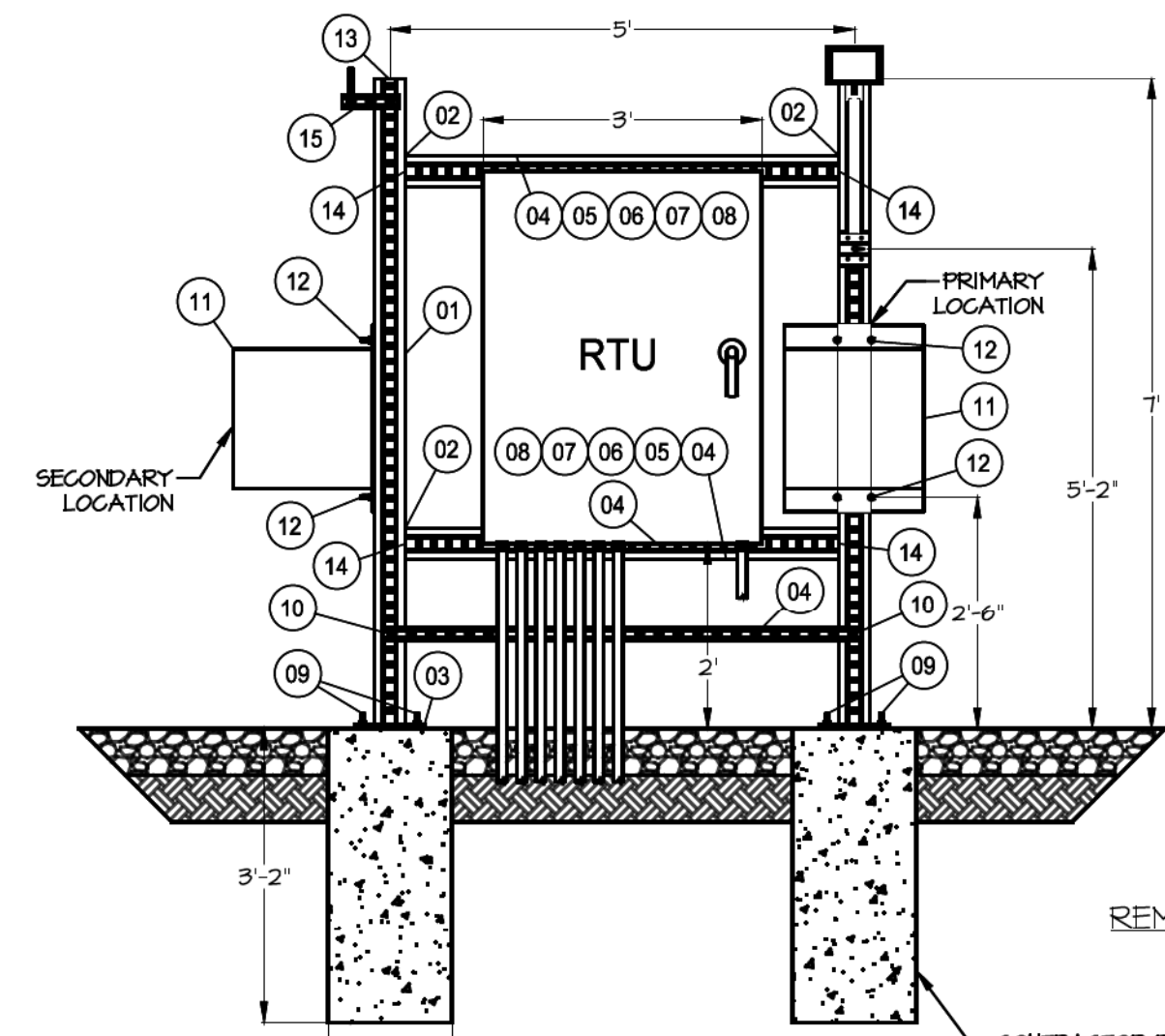
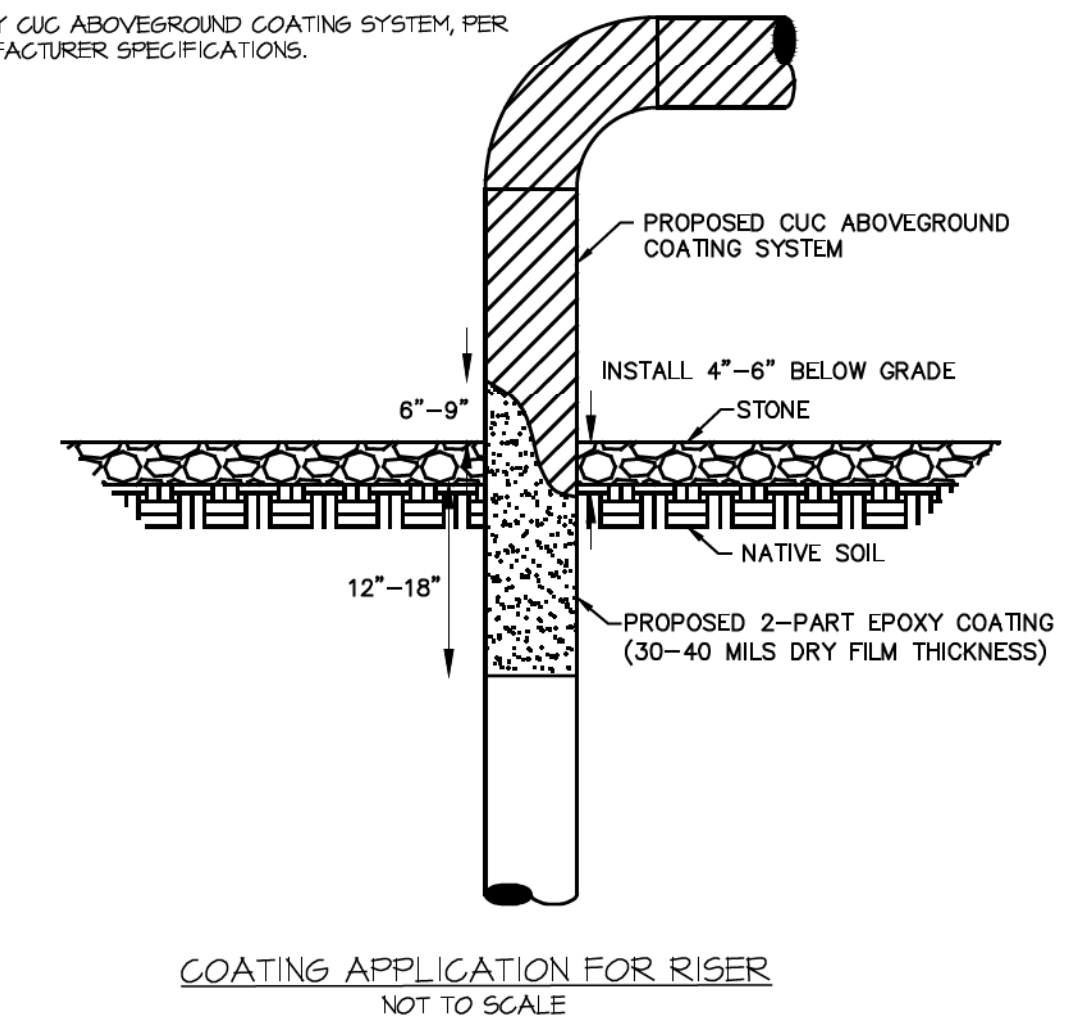

- BEFORE CLEANING OF PIPE MAKE SURE PIPE TEMPERATURE IS AT LEAST 5°F ABOVE THE DEW POINT. (IF APPLICABLE).
- POWER BRUSH OR SAND BLAST (NACE No 3 FINISH) PIPE UNTIL FREE OF RUST, DIRT, AND OTHER FOREIGN MATTER.
- APPLY DENSO PRIMER TO SPECIFIED AREA WHERE THE DENSO DENSYL TAPE WILL BE APPLIED.
- APPLY DENSO DENSYL TAPE UNTIL THE DENSO PRIMER IS COMPLETELY COVERED BY THE DENSYL TAPE. MAKE SURE TO APPLY THE TAPE WITH A 50% OVERLAP. ALSO MAKE SURE NO PRIMER CAN BE SEEN AFTER APPLYING THE WAX TAPE.
- APPLY DENSO UTILITY TAPE OVER THE DENSO MAX TAPE. START WRAPPING THE TAPE 4" BEFORE THE MAX TAPE STARTS AND END 4" AFTER IT ENDS.
- REFER TO DENSO PRODUCT SPECIFICATIONS GUIDE FOR SPECIFICATION & INSTALLATION DETAILS.

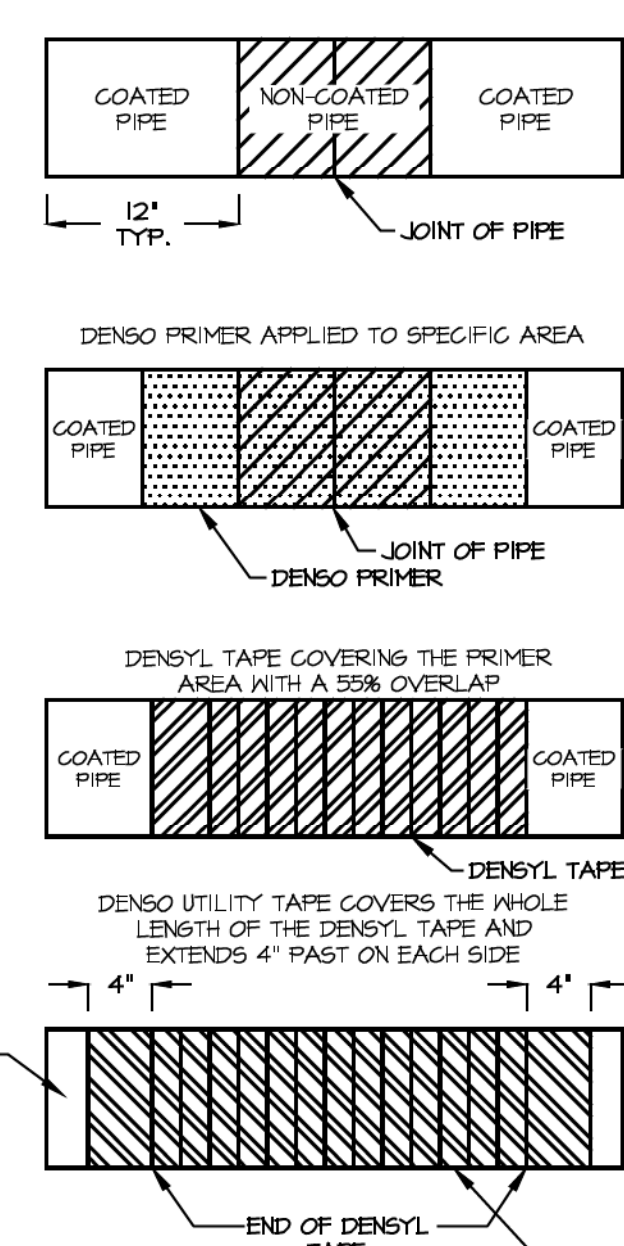

COATING APPLICATION FOR DENSO TAPE COATING
NOT TO SCALE

- VERIFY PIPE TEMPERATURE IS AT LEAST 5°F ABOVE THE DEW POINT BEFORE CLEANING OF PIPE. (IF APPLICABLE).
- POWER BRUSH OR ABRASIVE BLAST PIPE UNTIL FREE OF RUST, DIRT, AND OTHER FOREIGN MATTER (NEAR WHITE, SSPC-SP-10, NACE No 2 FINISH).
- CLEAN TOTAL OF 10' TO 21' SECTION OF PIPE.
- APPLY CANUSA-GPS HBE-95-B6 COATING TO THE FRESHLY CLEANED AREA OF THE PIPE.

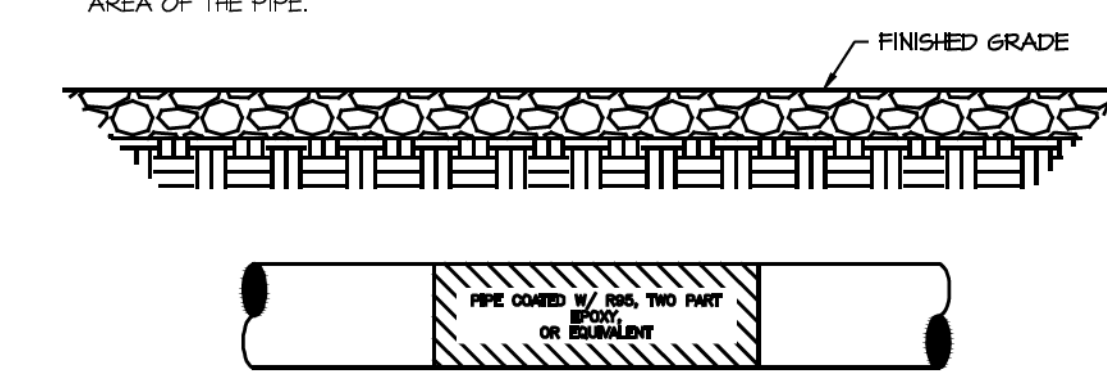

COATING APPLICATION FOR HBE-95-B6 OR ESNG APPROVED EQUIVALENT
NOT TO SCALE

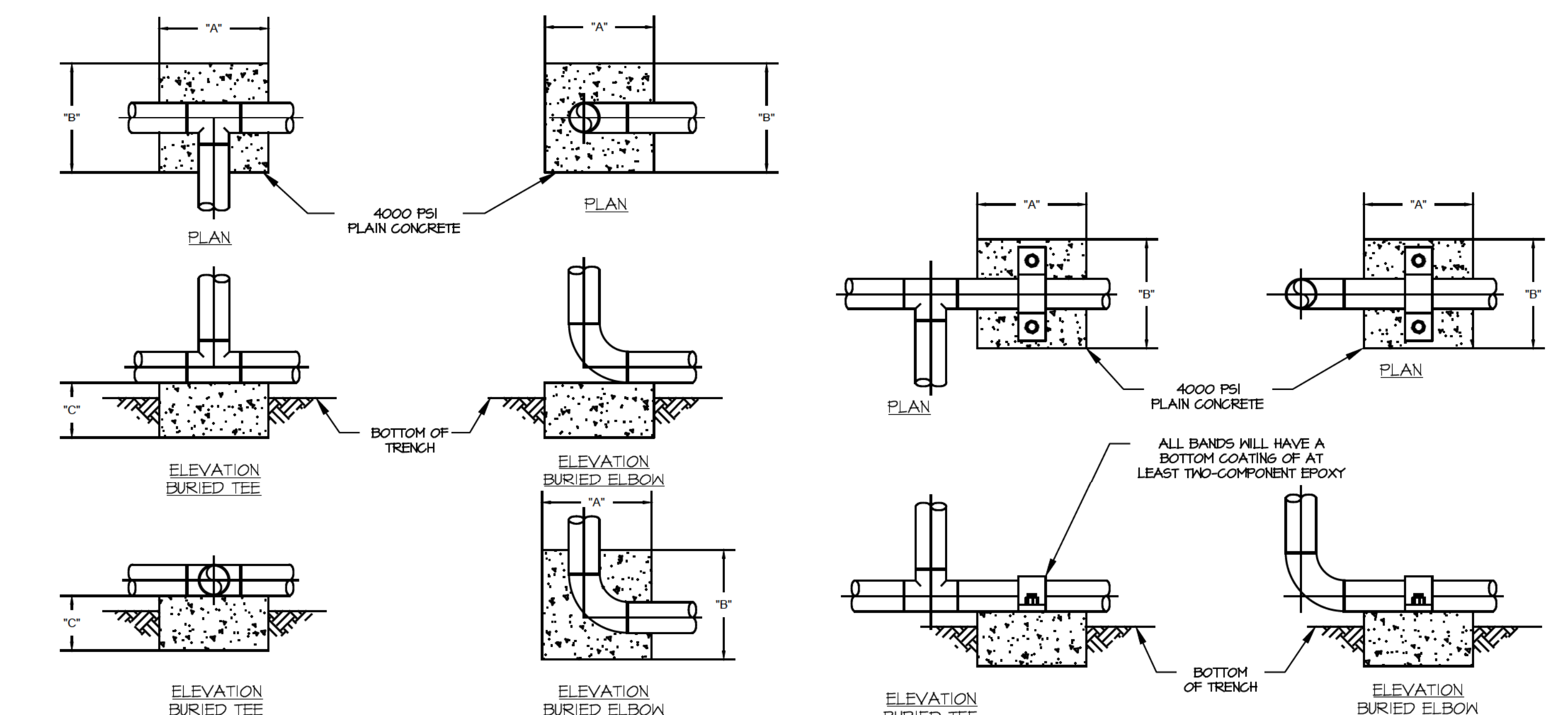

NOMINAL PIPE SIZE	"A"	"B"	"C"
2"	12"	12"	6"
3"	12"	12"	6"
4"	12"	12"	6"
6"	18"	18"	9"
8"	18"	18"	9"
10"	24"	24"	12"
12"	24"	24"	12"
14"	30"	30"	18"
16"	30"	30"	18"
18"	36"	36"	18"
20"	36"	36"	18"
24"	42"	42"	24"

CONCRETE FOOTER DETAILS
NOT TO SCALE

- GENERAL NOTES:
- CONTRACTOR TO FURNISH ALL MATERIALS.
 - CLEAN, COAT AND WRAP FITTINGS AND PIPE WHICH WILL COME IN CONTACT WITH CONCRETE.
 - PIPE AND FITTINGS SHALL BE WRAPPED WITH "CONED PIPE SAYER" OR EQUAL POLYETHYLENE MESH.
 - CONCRETE TO BE POURED TO CENTERLINE OF PIPING.
 - NO BACKFILL SHALL BE PLACED ON TOP OF CONCRETE UNTIL THE CONCRETE HAS HAD TIME TO SET UP.
 - BOTTOM OF CONCRETE SHALL BE PLACED ON SOLID FOOTING.
 - RIGID FORM WORK WILL NOT BE REQUIRED.
 - THIS SUPPORT IS NOT DESIGNED NOR INTENDED FOR A THRUST BLOCK.
 - CONTRACTOR TO USE 4000 PSI PLAIN CONCRETE OR "QUIKCRETE".

NOTE: CONTRACTOR TO SUPPLY ALL MATERIAL REQUIRED TO FABRICATE SUPPORTS ON THIS DRAWING

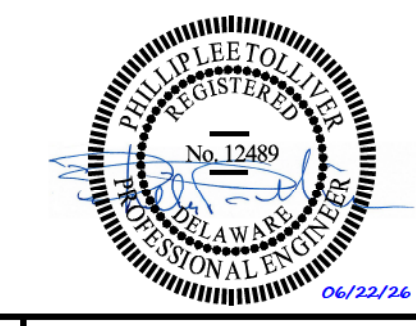

REVISIONS			
NO.	DATE	DESCRIPTION	BY

MIRA
MORRIS & RITCHIE ASSOCIATES, INC.
ENGINEERS, PLANNERS, SURVEYORS AND LANDSCAPE ARCHITECTS
111 RUTHAR DRIVE
NEWARK, DE 19711
(302) 326-2200
MRA@MIRA.COM
© 2025 MORRIS & RITCHIE ASSOCIATES, INC.

EASTERN SHORE
NATURAL GAS
500 ENERGY LANE, SUITE 200 DOVER, DE 19901
TELEPHONE (302) 734-6710 - FAX (302) 734-6745

CONSTRUCTION DETAILS
6" PROPOSED PIPELINE
CAMDEN CONTROLLER
KENT COUNTY, DE

ESNG PROJECT CODE:	ES XXXX	DATE:	6/19/2026
MRA PROJECT NO:	23098	SCALE:	AS SHOWN
DESIGN/CHECK BY:	JTH/CWB	SHEET:	11 OF 18

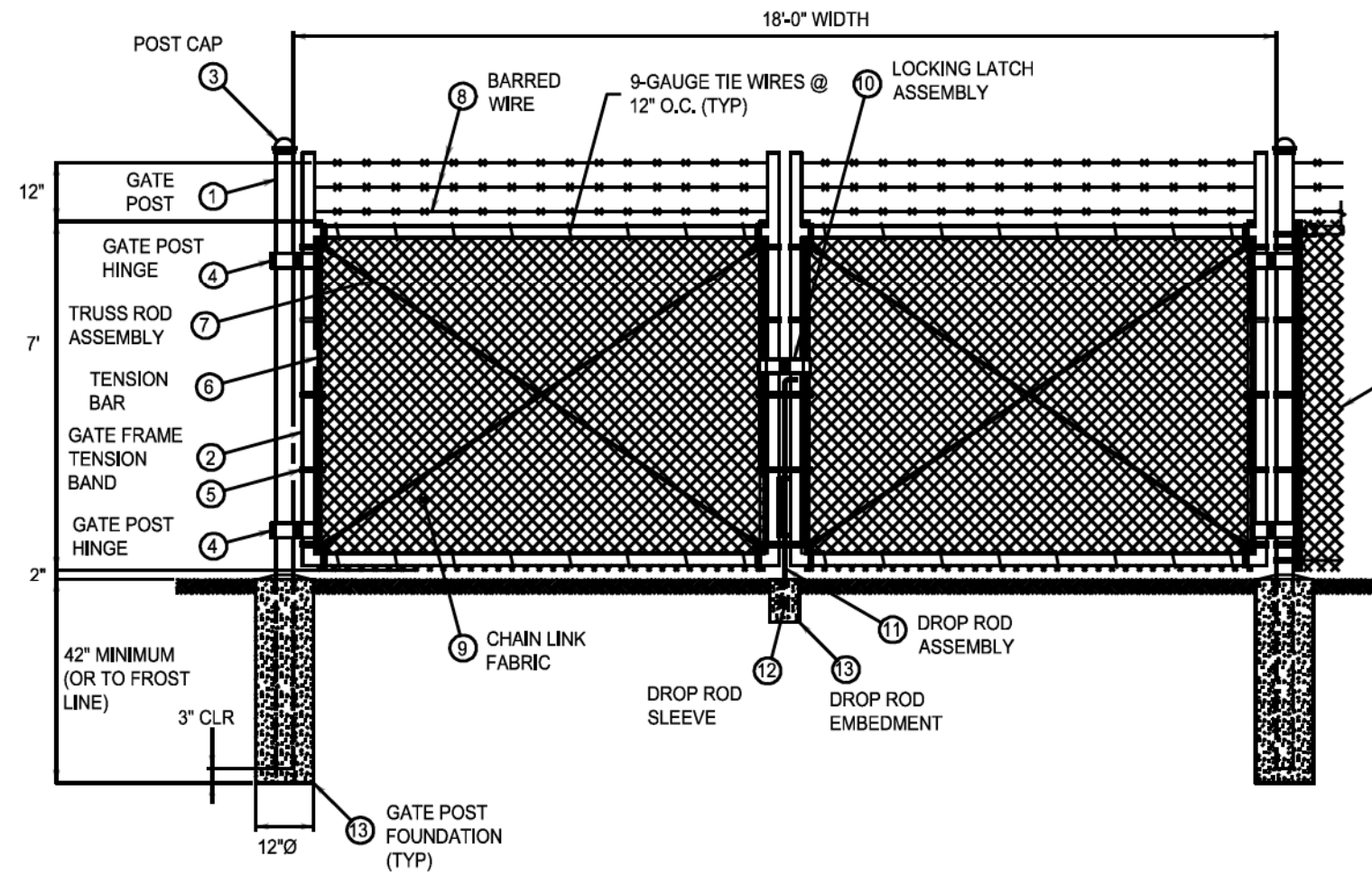

ELEVATION VIEW

DETAIL SWING GATE
NOT TO SCALE

MATERIALS SCHEDULE

- 4" SCHED 40 GALV STEEL PIPE
- 2" SCHED 40 GALV STEEL PIPE
- GALV STEEL POST CAP
- INDUSTRIAL HINGE
- GALV STEEL TENSION BAND
- GALV STEEL TENSION BAR
- DOUBLE TRUSS ROD ASSEMBLY CONSISTING OF:
 - (4) GALV STEEL TRUSS TIGHTENERS
 - (2) 3/8" DIA GALV STEEL TRUSS ROD
- 12-1/2" GAUGE GALV STEEL 4-POINT BARBED WIRE
- 9 GAUGE, ASTM-392, CLASS 1, 2" MESH, GALV CHAIN LINK FABRIC
- GALV STEEL LOCKING LATCH ASSEMBLY
- GALV STEEL DROP ROD ASSEMBLY
- GALV STEEL DROP ROD SLEEVE
- ALL CONCRETE SHALL HAVE A MINIMUM 28-DAY COMPRESSIVE STRENGTH OF 3000 PSI
- CHAIN LINK PRIVACY SLATS - GREEN

GENERAL NOTES:

- DESIGN, FABRICATION AND ERECTION OF STRUCTURAL STEEL SHALL BE IN ACCORDANCE WITH THE CURRENT EDITION OF THE AISC MANUAL OF STEEL CONSTRUCTION UNLESS NOTED OTHERWISE.
- ALL STEEL ANGLE, BAR, CHANNEL, FLATS, PLATE AND PIPE SHALL BE ASTM A36 HOT DIP GALVANIZED IN ACCORDANCE WITH ASTM A123 UNLESS NOTED OTHERWISE.
- ALL WELDING SHALL CONFORM TO AWS D1.1.
- ALL GALVANIZED SURFACES DAMAGED DURING CONSTRUCTION SHALL BE COATED WITH AN APPROVED COLD ZINC COMPOUND, REMOVE ALL SCALE & FOREIGN MATTER FROM THE SURFACE BEFORE APPLYING THE ZINC COMPOUND.
- GATE POST FOOTING SIZES ARE THE RECOMMENDED MINIMUM AND SHOULD BE REDESIGNED FOR POOR SOIL CONDITIONS.
- CONTRACTOR TO SUPPLY AND INSTALL ALL MATERIALS UNLESS NOTED OTHERWISE.

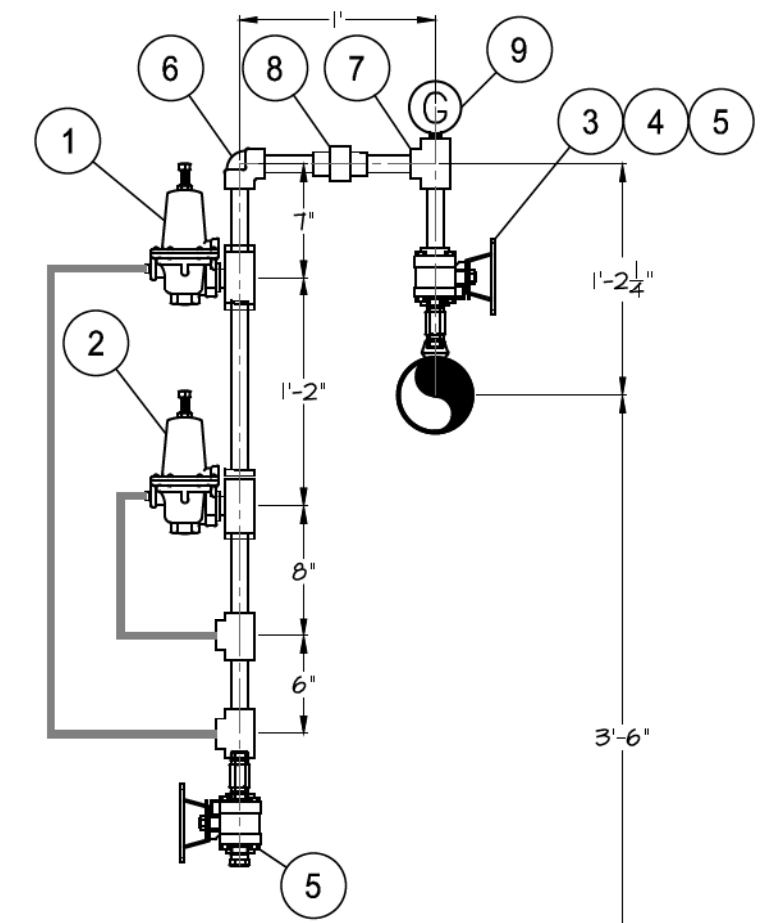

BACKUP GENERATOR TAP DETAIL
NOT TO SCALE

**PARKESBURG CAMDEN CONTROLLER - REGULATOR
BILL OF MATERIALS**

ITEM #	QUANTITY	UNITS	DESCRIPTION
1	1	EA	*REGULATOR, MONITOR, 3/4" NPT, FISHER TYPE 627M, DUCTILE IRON BODY/SPRING CASE, ALUMINUM/NITRILE TRIM, 3/32" ORIFICE, 15-80# SPRING RANGE
2	1	EA	*REGULATOR, WORKER, 3/4" NPT, FISHER TYPE 627M, DUCTILE IRON BODY/SPRING CASE, ALUMINUM/NITRILE TRIM, 3/32" ORIFICE, 15-80# SPRING RANGE
3	2	EA	THREADDLET, RUN SIZE 3/4"-1 1/2" X BRANCH SIZE 3/4", CLASS 3000 T-OLET, FORGED STEEL, XS, ASTM A694-F52
4	2	EA	HEX LONG NIPPLE, 3/4" MNPT, 3.00" LONG, 316 SS, SWAGELOK ORDERING NUMBER SS-12-HLN-3
5	2	EA	*VALVE, BALL, SWAGELOK WHITEY SERIES 60, 3/4" FNPT ENDS, W/ LOCKING ORANGE OVAL HANDLES.
6	1	EA	ELBOW, 90°, 3/4" FNPT ENDS, FORGED STEEL, ANSI B16.11, CLASS 3000
7	3	EA	TEE, STRAIGHT, 3/4" FNPT ENDS, FORGED STEEL, ANSI B16.11, CLASS 3000
8	1	EA	COUPLING, 3/4" FNPT ENDS, FORGED STEEL, ANSI B16.11, CLASS 3000
9	1	EA	*PRESSURE GAUGE, 0-1000 PSI RANGE, STAINLESS STEEL, 1/4" MNPT STEM, 2-1/2" DIAL FACE, GLYCERIN FILLED, SWAGELOK PSI-63C-PS1000-LA01-J

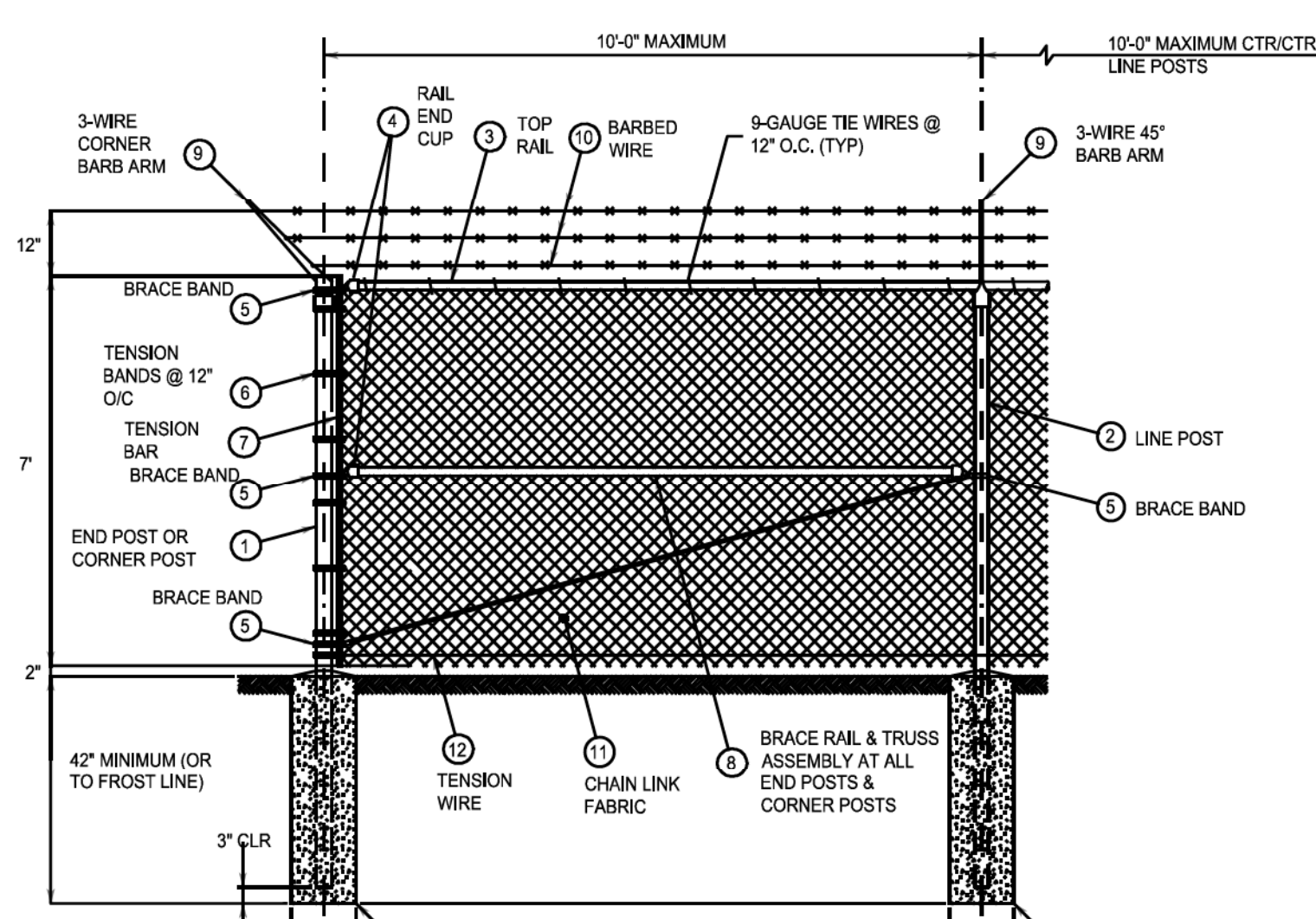

ELEVATION VIEW

DETAIL CHAIN LINK FENCE

MATERIALS SCHEDULE

- 3" SCHED 40 GALV STEEL PIPE
- 2" SCHED 40 GALV STEEL PIPE
- 1-1/2" SCHED 40 GALV STEEL PIPE
- 1-1/2" GALV STEEL RAIL END CUP
- GALV STEEL BRACE BAND
- GALV STEEL TENSION BAND
- GALV STEEL TENSION BAR
- BRACE RAIL & TRUSS ASSEMBLY CONSISTING OF:
 - (1) 1-1/2" SCHED 40 GALV STEEL PIPE
 - (2) GALV STEEL TRUSS TIGHTENERS
 - (1) 3/4" DIA GALV STEEL TRUSS ROD
- 3-WIRE 45° GALV STEEL BARB ARM
- 12-1/2" GAUGE GALV STEEL 4-POINT BARBED WIRE
- 9-GAUGE, ASTM-392, CLASS 1, 2" MESH, GALV CHAIN LINK FABRIC
- 7-GAUGE GALV STEEL TENSION WIRE
- ALL CONCRETE SHALL HAVE A MINIMUM 28-DAY COMPRESSIVE STRENGTH OF 3000 PSI

GENERAL NOTES:

- DESIGN, FABRICATION AND ERECTION OF STRUCTURAL STEEL SHALL BE IN ACCORDANCE WITH THE CURRENT EDITION OF THE AISC MANUAL OF STEEL CONSTRUCTION UNLESS NOTED OTHERWISE.
- ALL STEEL ANGLE, BAR, CHANNEL, FLATS, PLATE AND PIPE SHALL BE ASTM A36 HOT DIP GALVANIZED IN ACCORDANCE WITH ASTM A123 UNLESS NOTED OTHERWISE.
- ALL WELDING SHALL CONFORM TO AWS D1.1.
- ALL GALVANIZED SURFACES DAMAGED DURING CONSTRUCTION SHALL BE COATED WITH AN APPROVED COLD ZINC COMPOUND, REMOVE ALL SCALE & FOREIGN MATTER FROM THE SURFACE BEFORE APPLYING THE ZINC COMPOUND.
- GATE POST FOOTING SIZES ARE THE RECOMMENDED MINIMUM AND SHOULD BE REDESIGNED FOR POOR SOIL CONDITIONS.
- CONTRACTOR TO SUPPLY AND INSTALL ALL MATERIALS UNLESS NOTED OTHERWISE.
- FOR THE PARKESBURG POW-MIA CONNECTOR, ALL LINE POSTS SHALL BE 3" DUE TO THE INSTALLATION OF PRIVACY SLATS.

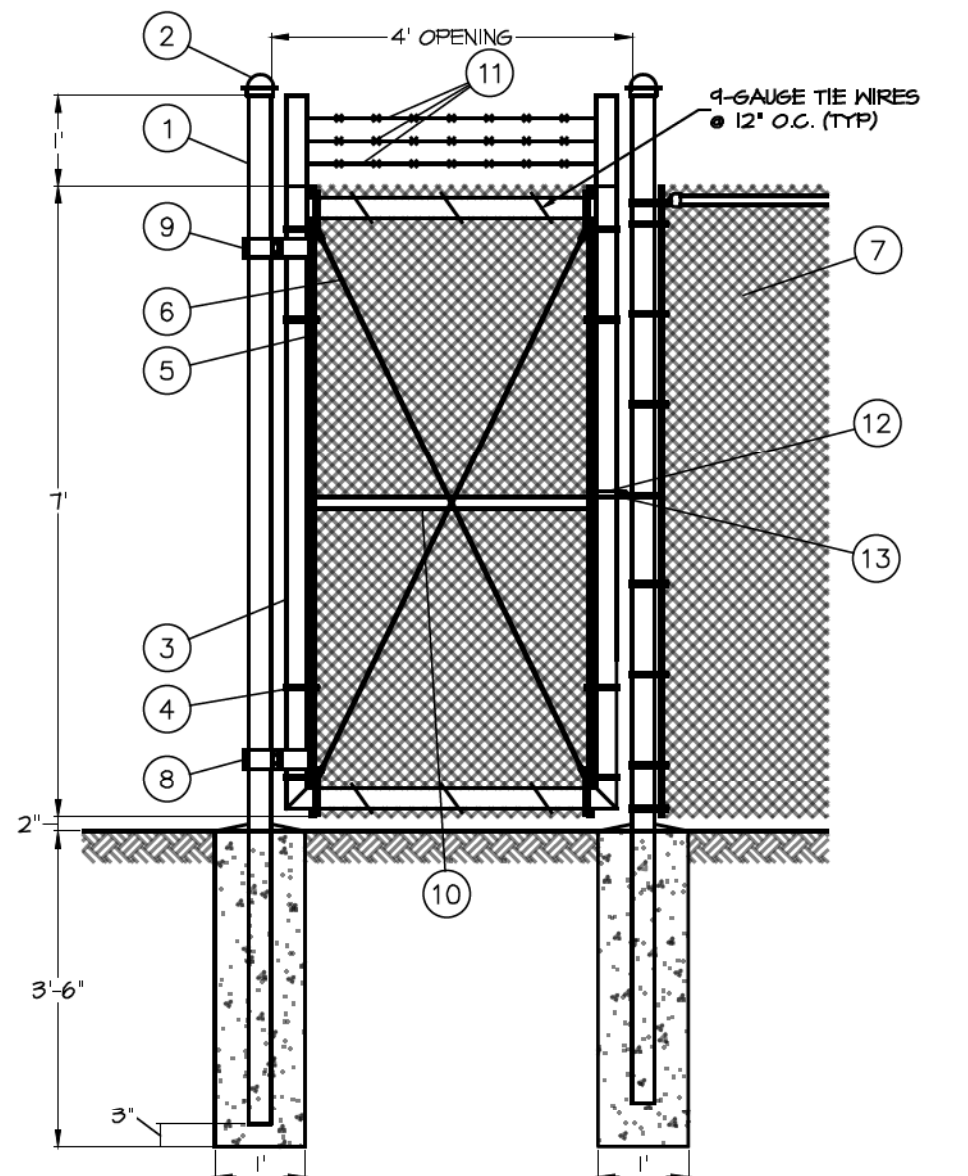

MAN GATE DETAIL
N.T.S.

PART #	DESCRIPTION
1	3" SCHED 40 GALV STEEL GATE POST, OR APPROX EQUAL
2	GALV STEEL POST CAP
3	GALV STEEL GATE FRAME
4	GALV STEEL TENSION BAND
5	GALV STEEL TENSION BAR
6	DOUBLE TRUSS ROD ASSEMBLY CONSISTING OF: FOUR GALV PRESSED STEEL TRUSS TIGHTENERS AND TWO 3/8" DIA GALV STEEL TRUSS ROD
7	9-GAUGE, ASTM-392, CLASS 1, 2" MESH, GALV CHAIN LINK FABRIC
8	INDUSTRIAL HINGE ASSEMBLY
9	ALL CONCRETE SHALL HAVE A MINIMUM 28-DAY COMPRESSIVE STRENGTH OF 3000 PSI
10	GALV STEEL CENTER BRACE
11	12-1/2" GAUGE GALV STEEL 4-POINT BARBED WIRE
12	GALVANIZED CHAIN LINK FENCE GATE FORK LATCH ASSEMBLY
13	MERCURIES LOCK

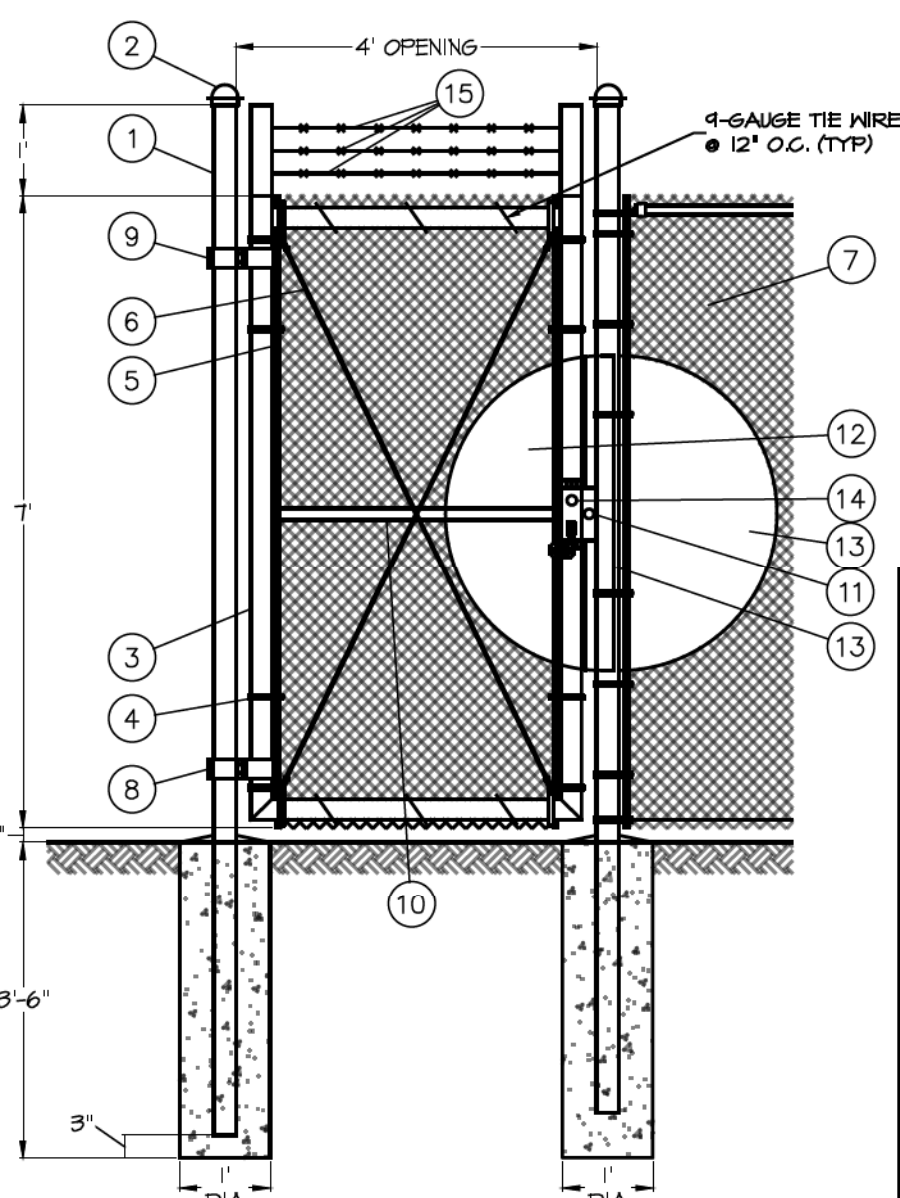

EMERGENCY MAN GATE DETAIL
N.T.S.

PART #	DESCRIPTION
1	3" SCHED 40 GALV STEEL GATE POST, OR APPROX EQUAL
2	GALV STEEL POST CAP
3	GALV STEEL GATE FRAME
4	GALV STEEL TENSION BAND
5	GALV STEEL TENSION BAR
6	DOUBLE TRUSS ROD ASSEMBLY CONSISTING OF: FOUR GALV PRESSED STEEL TRUSS TIGHTENERS AND TWO 3/8" DIA GALV STEEL TRUSS ROD
7	9-GAUGE, ASTM-392, CLASS 1, 2" MESH, GALV CHAIN LINK FABRIC
8	INDUSTRIAL HINGE ASSEMBLY
9	ALL CONCRETE SHALL HAVE A MINIMUM 28-DAY COMPRESSIVE STRENGTH OF 3000 PSI
10	GALV STEEL CENTER BRACE
11	PICK-PROOF BAR
12	1/8" THK GALV STEEL PL W/18" RADIUS BOLTED TO GATE FRAME WITH 1/4" STAINLESS STEEL BUTTON HEAD ALLEN BOLTS
13	1 1/2" TO GALV STEEL PL OR ANGLE WELDED TO THE OUTSIDE OF THE VERTICAL GATE FRAME SO THAT IT OVERLAPS THE ADJACENT GATE POST WHEN GATE IS IN THE CLOSED POSITION TO PREVENT INTRUSION OR ACCESS TO LATCH ASSEMBLY BETWEEN THE FRAME AND POST
14	LOCKING LATCH ASSEMBLY CONSISTING OF: CAST ALUMINUM BODY, CAST ALUMINUM PADDLE, AND BRONZE AND STAINLESS INTERNALS (OR APPROVED EQUAL)
15	12-1/2" GAUGE GALV STEEL 4-POINT BARBED WIRE

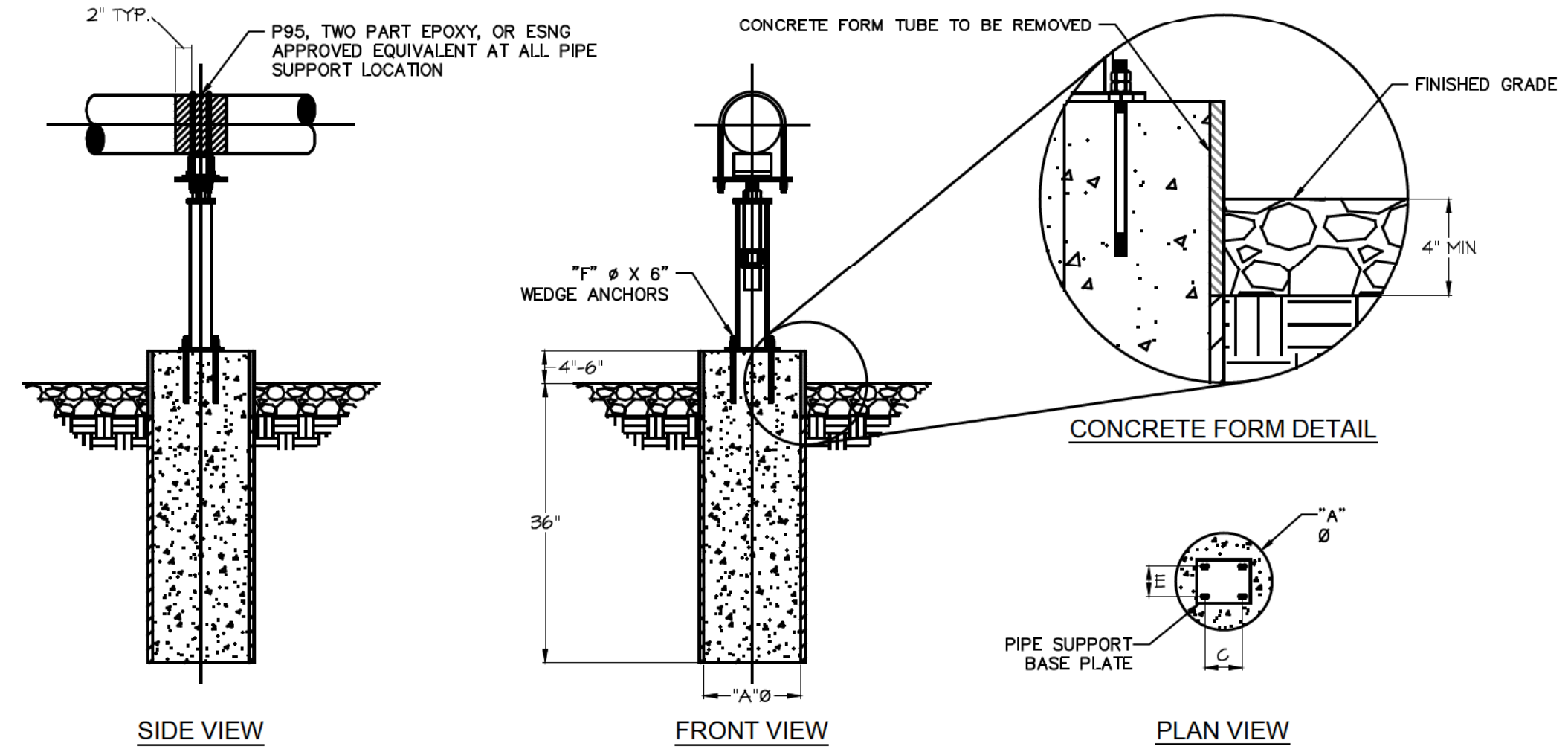

SIDE VIEW

FRONT VIEW

PLAN VIEW

GENERAL NOTES:

- CONTRACTOR TO FURNISH ALL MATERIALS.
- BOTTOM OF CONCRETE SHALL BE PLACED ON LEVEL BASE
- CONTRACTOR TO USE 4000 PSI PLAIN CONCRETE OR "QUICKCRETE"
- RIGID FORM WORK WILL NOT BE REQUIRED
- WAX OR EQUIVALENT RELEASE AGENT MAY BE APPLIED TO INSIDE OF CONCRETE TUBE FORM TO FACILITATE DISBANDING
- NO BACKFILL SHALL BE PLACED ON TOP OF FORM UNTIL THE CONCRETE HAS HAD TIME TO SET UP
- CONCRETE TUBE FORM TO BE REMOVED AT MINIMUM 4" BELOW FINAL GRADE POST-CURE

PIPE COATING NOTES:

- VERIFY PIPE TEMPERATURE IS AT LEAST 5°F ABOVE THE DEW POINT BEFORE CLEANING OF PIPE. (IF APPLICABLE)
- POWER BRUSH OR ABRASIVE BLAST PIPE UNTIL FREE OF RUST, DIRT, AND OTHER FOREIGN MATTER (NEAR WHITE, SSPC-SP-10, NACE No 2 FINISH)
- CLEAN TOTAL DESIRED SECTION OF PIPE THAT WILL BE COATED
- APPLY CANUSA-CPS HBE-95-BG, PROTAL 7200 OR EQUIVALENT ON ALL SIDES OF THE PIPE SUPPORT 2" TYP.
- INSTALLATION SHALL BE IN ACCORDANCE WITH MANUFACTURE RECOMMENDATION.

NOT TO SCALE

NOTE: CONTRACTOR TO SUPPLY ALL MATERIAL REQUIRED TO CONSTRUCT CONCRETE FOOTERS

MODEL NO.	PIPE SIZE	"A" Ø	BASE PL THK.	"C"	"E"	SLOTTED HOLES	"F" Ø
204	2	16"	1/2	5	3 1/2	5/8x1 1/2	1/2
	3	16"	1/2	5	3 1/2	5/8x1 1/2	1/2
	4	16"	1/2	5	3 1/2	5/8x1 1/2	1/2
	6	16"	1/2	7	5 1/2	5/8x1 1/2	1/2
510	8	16"	1/2	7	5 1/2	5/8x1 1/2	1/2
	10	16"	1/2	7	5 1/2	5/8x1 1/2	1/2
	12	18"	5/8	9	7 1/2	3/4x1 1/2	5/8
	14	18"	5/8	9	7 1/2	3/4x1 1/2	5/8
1218	16	18"	5/8	9	7 1/2	3/4x1 1/2	5/8
	18	18"	5/8	9	7 1/2	3/4x1 1/2	5/8
	20	18"	5/8	9	7 1/2	7/8x1 1/2	3/4
	22	18"	5/8	9	7 1/2	7/8x1 1/2	3/4
2024	24	18"	5/8	9	7 1/2	7/8x1 1/2	3/4

CONCRETE BASE DETAIL FOR E-Z LINE FKOB SERIES PIPE SUPPORTS

CONSTRUCTION DETAILS

6" PROPOSED PIPELINE
CAMDEN CONTROLLER
KENT COUNTY, DE

ESNG PROJECT CODE:	ES XXXX	DATE:	6/19/2026
MRA PROJECT NO:	23098	SCALE:	AS SHOWN
DESIGN/CHECK BY:	JTH/CWB	SHEET:	12 OF 18

NOTE: ASSEMBLY TO BE DONE BY EASTERN SHORE NATURAL GAS



REVISIONS			
NO.	DATE	DESCRIPTION	BY



MORRIS & RITCHIE ASSOCIATES, INC.
ENGINEERS, PLANNERS, SURVEYORS AND
LANDSCAPE ARCHITECTS
111 RUTHER DRIVE
NEWARK, DE 19711
(302) 326-2200
MRA@TA.COM
© 2025 MORRIS & RITCHIE ASSOCIATES, INC.



500 ENERGY LANE, SUITE 200 DOVER, DE 19901
TELEPHONE (302) 734-6710 - FAX (302) 734-6745

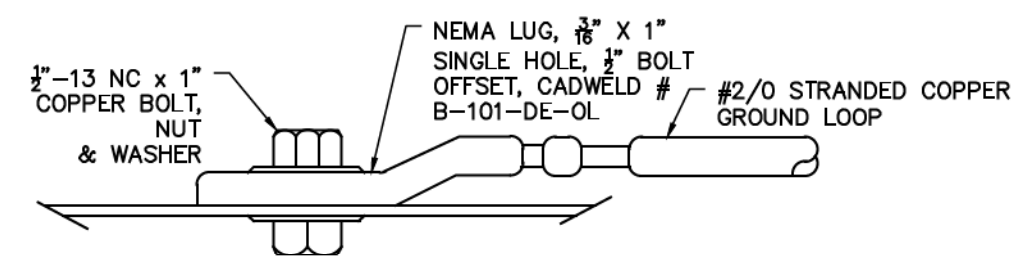

TYPICAL EQUIPMENT BOLTED GROUND LUG CONNECTION
(NOT TO SCALE)

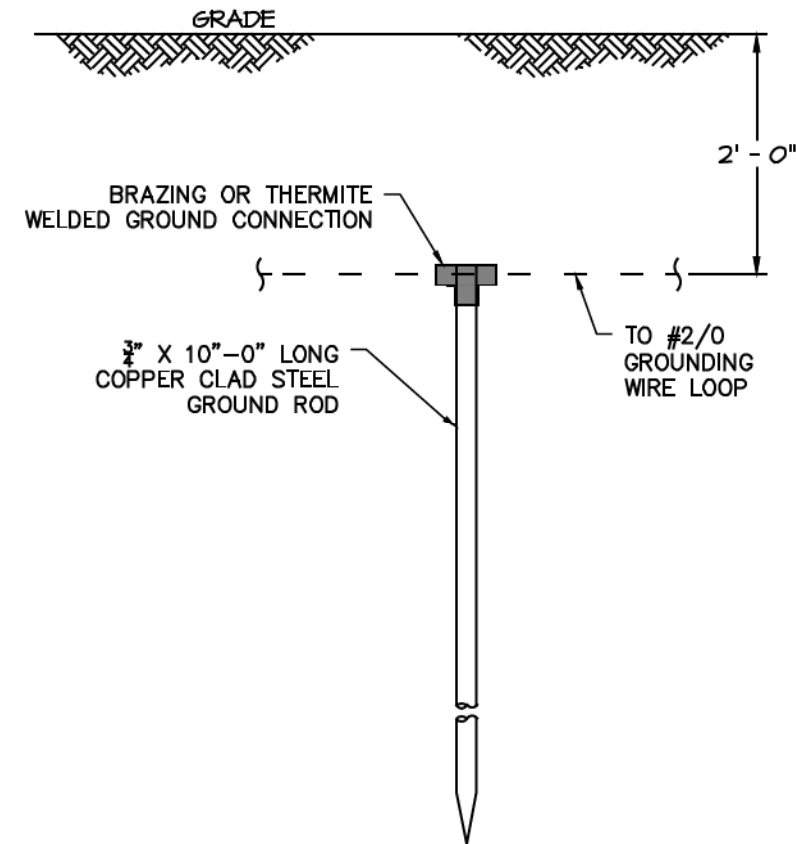

GROUND ROD INSTALLATION
(NOT TO SCALE)

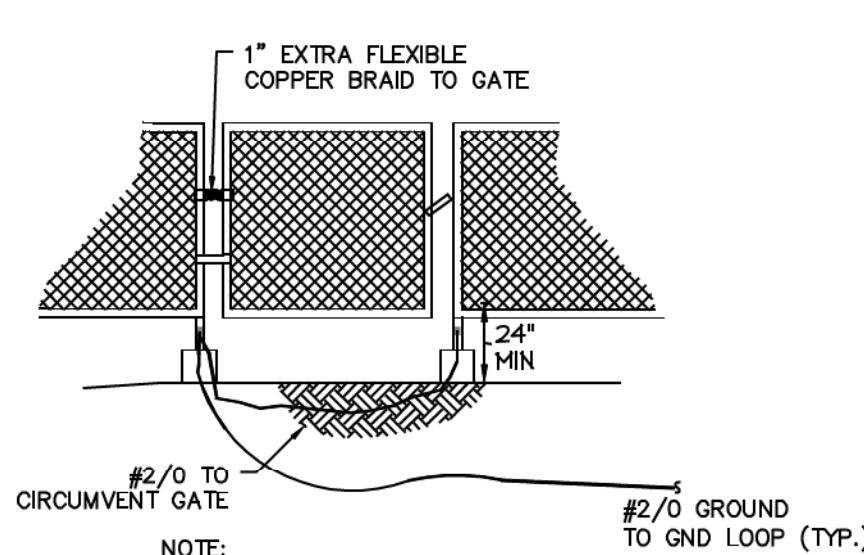

GATE & FENCE GROUNDING
(NOT TO SCALE)

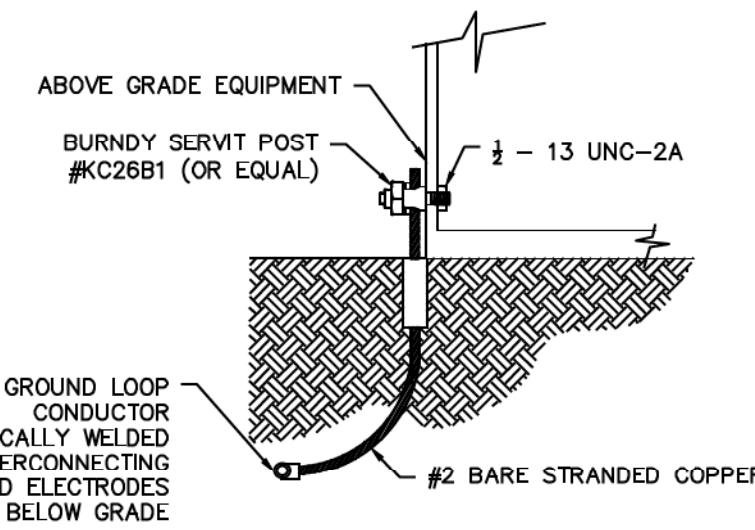

TYPICAL GROUND CONNECTION
(NOT TO SCALE)

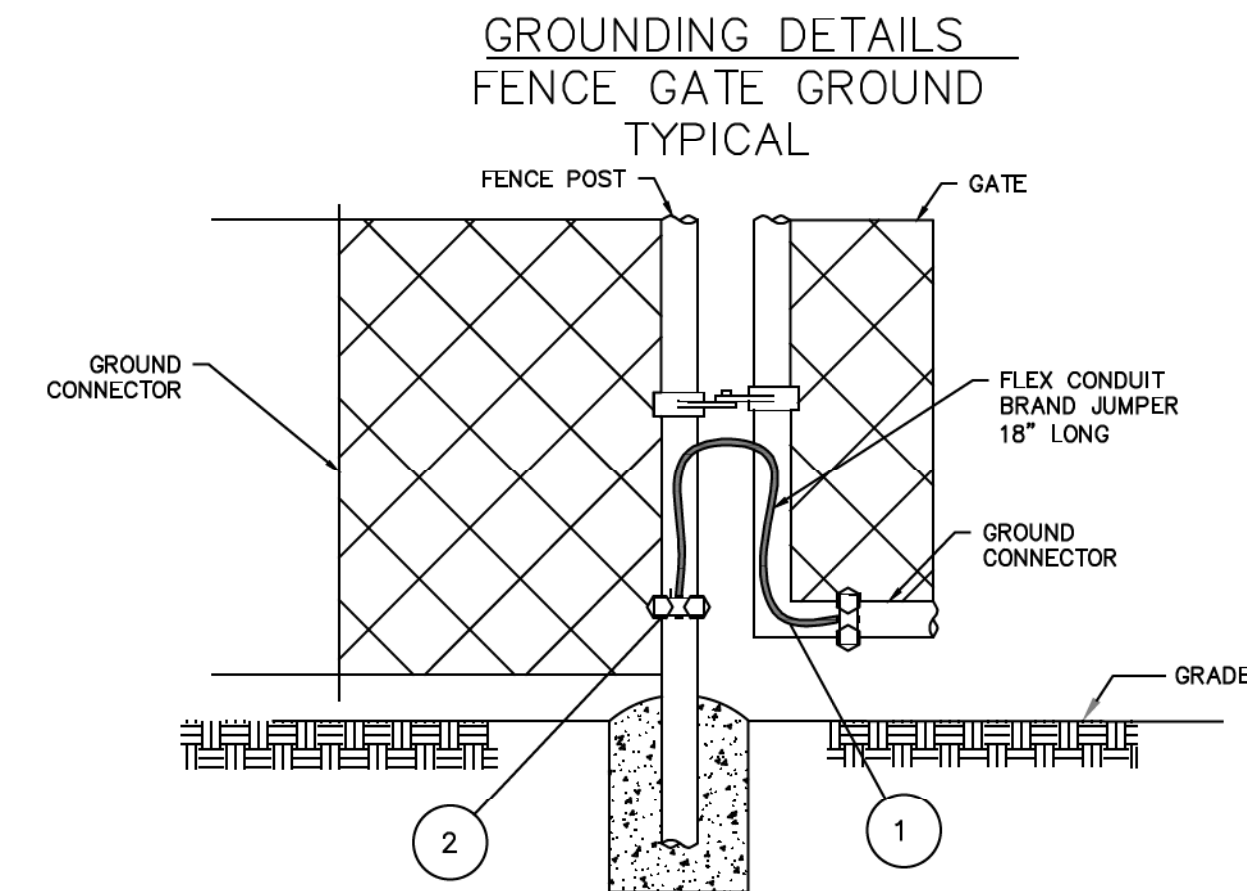

MATERIAL		
ITEM	QUANTITY	DESCRIPTION
1	AS REQ'D	WIRE, #2 AWG HMWPE, GREEN
2	2	GROUNDING CONNECTOR, BURNDY TYPE "GG"

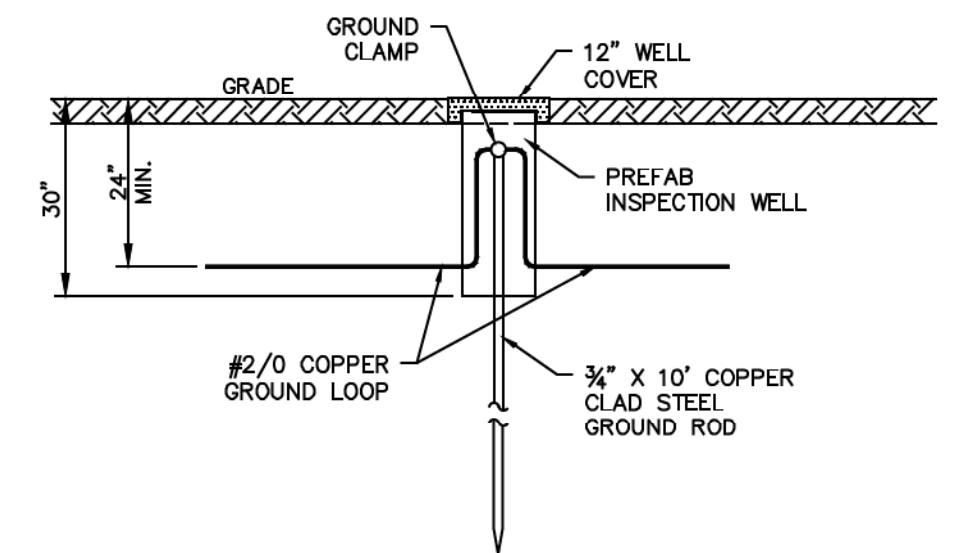

DETAIL #10
GROUND ROD INSPECTION WELL
(NOT TO SCALE)

GROUNDING DETAILS
CADWELD CONNECTION
TYPICAL

CABLE SIZE				CADWELD CONNECTION	
RUN	TAP	MOLD NUMBER	WELD METAL		
#2/0	#2/0	TAC-2G2G	#90		
#2/0	#2	TAC-2G1V	#45		

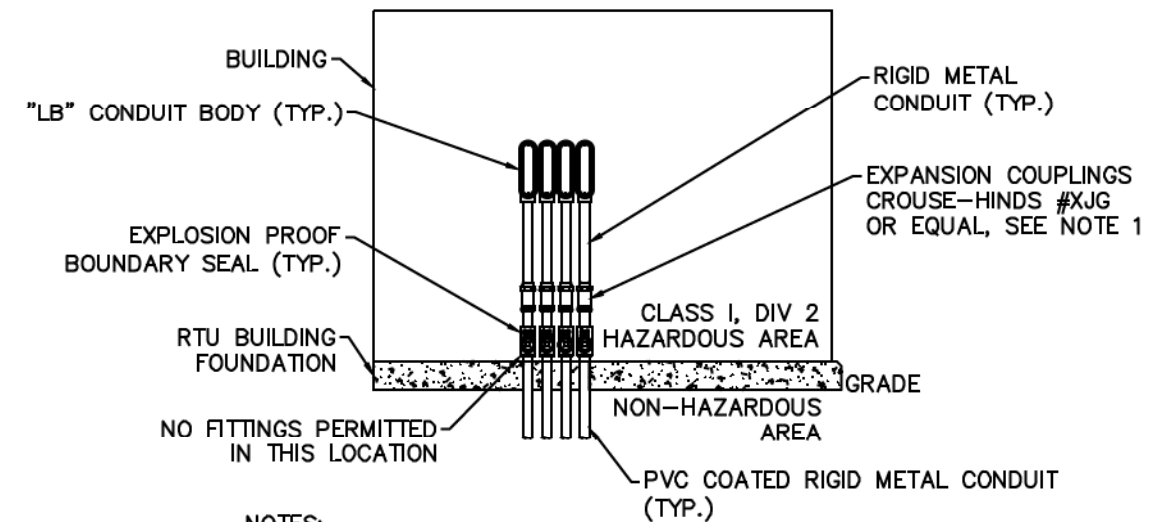
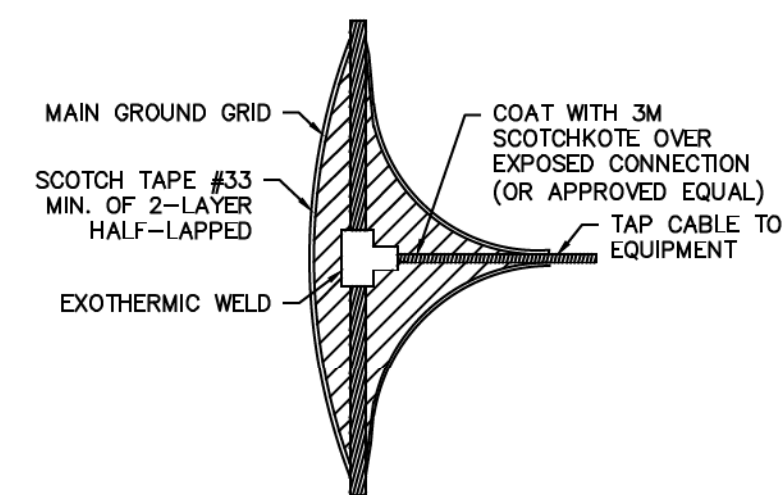

DETAIL #3
EXTERIOR CONDUIT TO BUILDING INSTALLATION
(NOT TO SCALE)

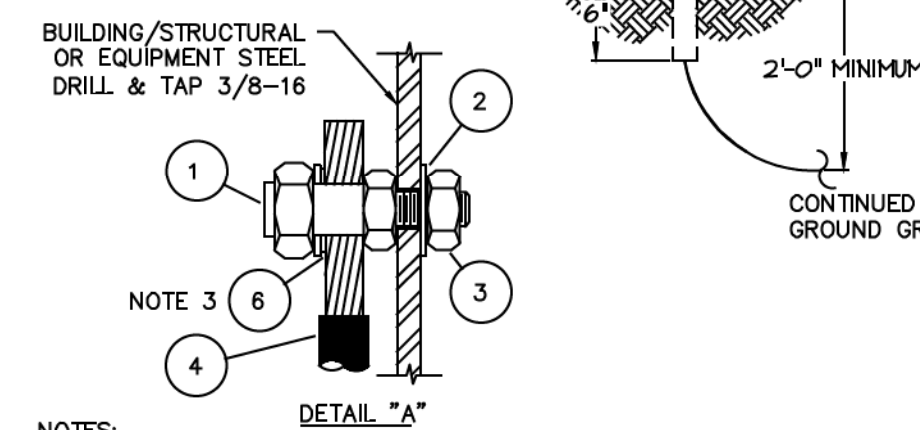

MATERIAL		
ITEM	QUANTITY	DESCRIPTION
1	1	GROUNDING CONNECTOR, SERVIT PST, #2 AWG TO FLAT SURFACE, BURNDY TYPE KC
2	1	WASHER, 3/8", SPLIT LOCKWASHER, SILICON BRONZE, BURNDY TYPE 38-SW-BOX
3	1	NUT, 3/8-16, SILICON BRONZE, BURNDY TYPE 38C-HEN-BOX
4	AS REQ'D	WIRE, #2 AWG, STRANDED HMWPE INSULATED GREEN COPPER.
5	AS REQ'D	CONDUIT SLEEVE, 1" SCH. 80 PVC
6	AS REQ'D	OXIDE-INHIBITING JOINT COMPOUND, BURNDY TYPE PENETROX A-13

GROUNDING DETAILS
SKID/STRUCTURE GROUNDING TYPICAL

BILL OF MATERIALS-SSD INSTALLATION DETAIL #1		
NO.	QUANTITY	DESCRIPTION
1	1	SSD CONDUCTORS, MTL-6-36-B-X, - #6 AWG WIRE, FURNISHED WITH COMPRESSION TERMINALS
2	1	DAIRYLAND SOLID-STATE DECOUPLER SSD-(3/1)-1.2-100
3	2	M8 THREADED STUD PIN BRAZING KIT, BAC PART #278-190-0430
4	2	CERAMIC FERRULE FOR THREADED PINS
5	1	HEX NUT, M8-1.25, 316-SS OR APPROVED EQUIVALENT
6	1	FLAT WASHER, 5/16" DIAMETER, 316-SS OR APPROVED EQUIVALENT
7	1	SSD MOUNTING HARDWARE, DAIRYLAND STUD MOUNTING KIT: HCN-M8
8	1	HEX NUT, 3/8-16, 316-SS OR APPROVED EQUIVALENT
9	1	FLAT WASHER, 3/8" DIAMETER, 316-SS OR APPROVED EQUIVALENT
10	1	STUD, 3/8"-16, 316-SS OR APPROVED EQUIVALENT
11	1	BURNDY COMPRESSION TERMINAL, TERMINAL CRIMPED TO 2/0 WIRE AND BOLTED TO POSITIVE TERMINAL, BURNDY PART NUMBER: YA26LBOX

- NOTES:
- M8 PINS TO BE PIN-BRAZED ONTO PIPE. NO CLOSER THAN 3" FROM ANY WELD. SSD BRACKET TO BE MOUNTED ON PINS. CONDUCTORS TO BE CUT TO SHORTEST LENGTH POSSIBLE & RUN IN THE MOST DIRECT MANNER BETWEEN THE SSD TERMINAL AND THE CONNECTION POINT.
 - CONNECT THE NEGATIVE TERMINAL OF THE DECOUPLING DEVICE TO CATHODICALLY PROTECTED PIPE AND THE POSITIVE TERMINAL TO STATION SIDE PIPE.
 - EXACT ORIENTATION OF SSD IS TO BE DETERMINED IN THE FIELD.
 - SURFACE IS TO BE PREPPED AND PAINTED ACCORDING TO ESGN SPECIFICATIONS FOR ANY PIN-BRAZING.
 - ALL CRIMPED RING TERMINALS ON CONDUCTORS ARE TO BE COVERED WITH HEAT SHRINK WRAP.

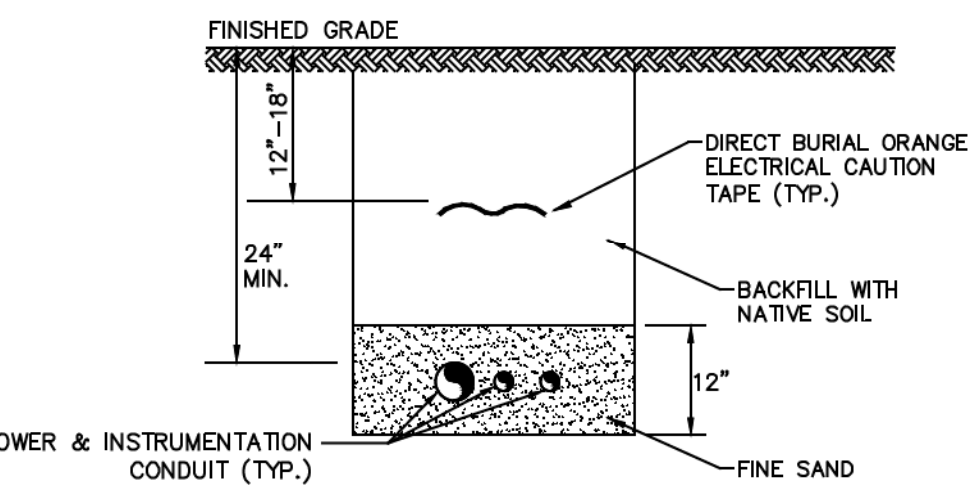

OPEN BOTTOM PULL BOX - TYPICAL
(NOT TO SCALE)

DETAIL #2
UNDERGROUND CABLE/CONDUIT BURIAL
(NOT TO SCALE)

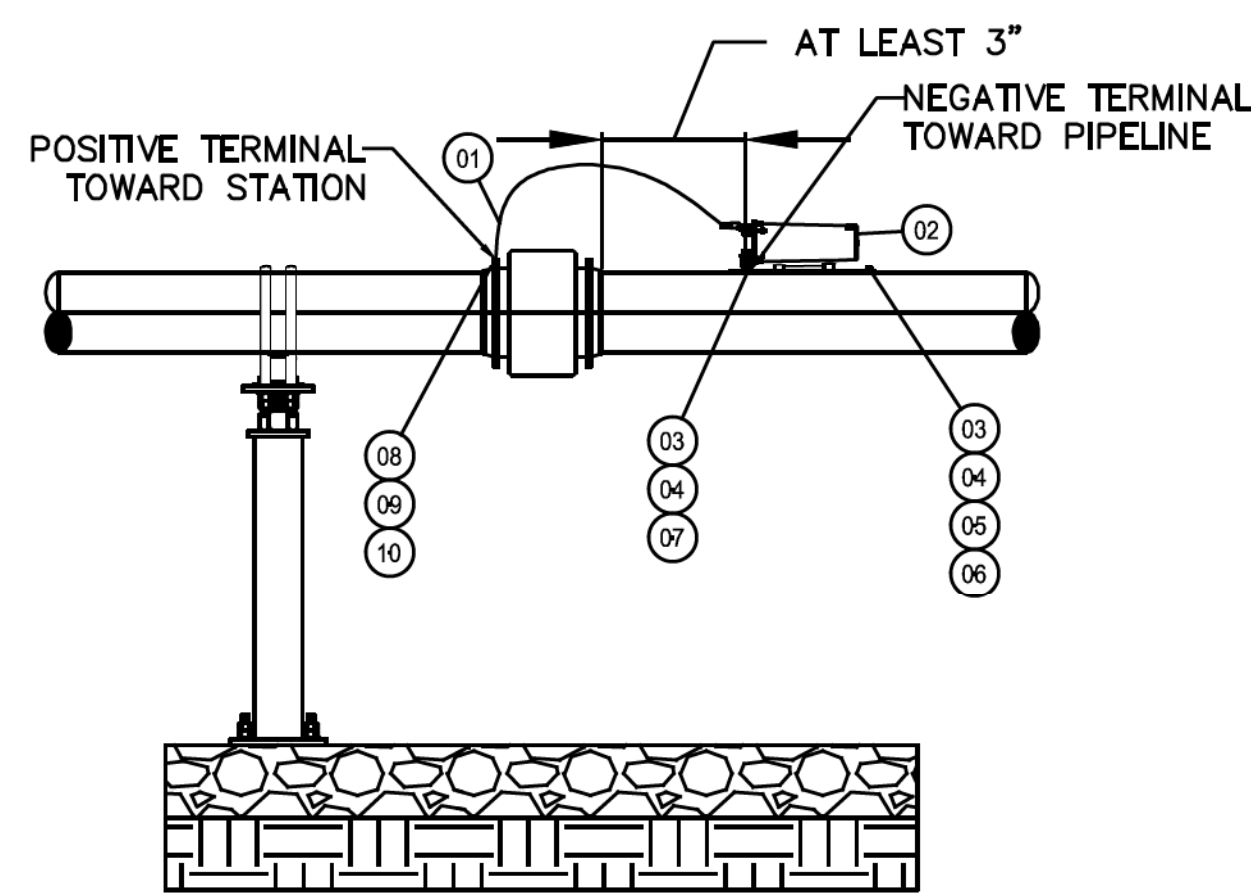

SSD INSTALLATION DETAIL #1:
INSTALLATION ACROSS A HORIZONTALLY
INSTALLED MONOLITHIC INSULATOR
NOT TO SCALE

MASTER nVENT ERICO CADWELD MOLD AND METAL MATERIALS**						
APPLICATION	RUN	TAP	MOLD NUMBER	WELDING MATERIAL	CADWELD PLUS WELDING MATERIAL	NOTES
GROUNDING	#2/0	GROUND ROD	GT182G	#115	#115PLUSF20	GROUND ROD TO GROUND HEADER TEE CONNECTION
GROUNDING	2" - 4" PIPE	#2/0	VSC2GV3C	#90	#90PLUSF20	TYP. FENCE CONNECTION
GROUNDING	1-1/2" - 4" PIPE	#2	VSC1TV3C	#45	#45PLUSF20	TYP. FENCE CONNECTION
GROUNDING	1-1/2" - 4" PIPE	#4	VSC1LV3C	#45	#45PLUSF20	TYP. FENCE CONNECTION
GROUNDING	#2/0	#2/0	PTC2G2G	#115	#115PLUSF20	GROUND ROD TO GROUND HEADER OVERLAP CONNECTION
GROUNDING	#2/0	#2	PTC2G1V	#90	#90PLUSF20	EQUIPMENT TO GROUND HEADER OVERLAP CONNECTION
GROUNDING	#2/0	#2/0	PTC2G1V	#90	#90PLUSF20	GROUND LOOP OVERLAP CONNECTOR

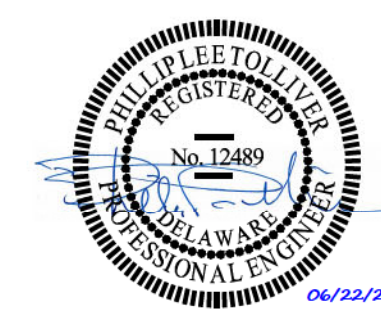

REVISIONS			
NO.	DATE	DESCRIPTION	BY

MIRA
MORRIS & RITCHIE ASSOCIATES, INC.
ENGINEERS, PLANNERS, SURVEYORS AND LANDSCAPE ARCHITECTS
111 RUTHAR DRIVE
NEWARK, DE 19711
(302) 326-2200
MRA@GMAIL.COM
© 2025 MORRIS & RITCHIE ASSOCIATES, INC.

EASTERN SHORE
NATURAL GAS
500 ENERGY LANE, SUITE 200 DOVER, DE 19901
TELEPHONE (302) 734-6710 - FAX (302) 734-6745

CONSTRUCTION DETAILS
6" PROPOSED PIPELINE
CAMDEN CONTROLLER
KENT COUNTY, DE

ESNG PROJECT CODE: ES XXXX	DATE: 6/19/2026
MRA PROJECT NO: 23098	SCALE: AS SHOWN
DESIGN/CHECK BY: JTH/CWB	SHEET: 13 OF 18

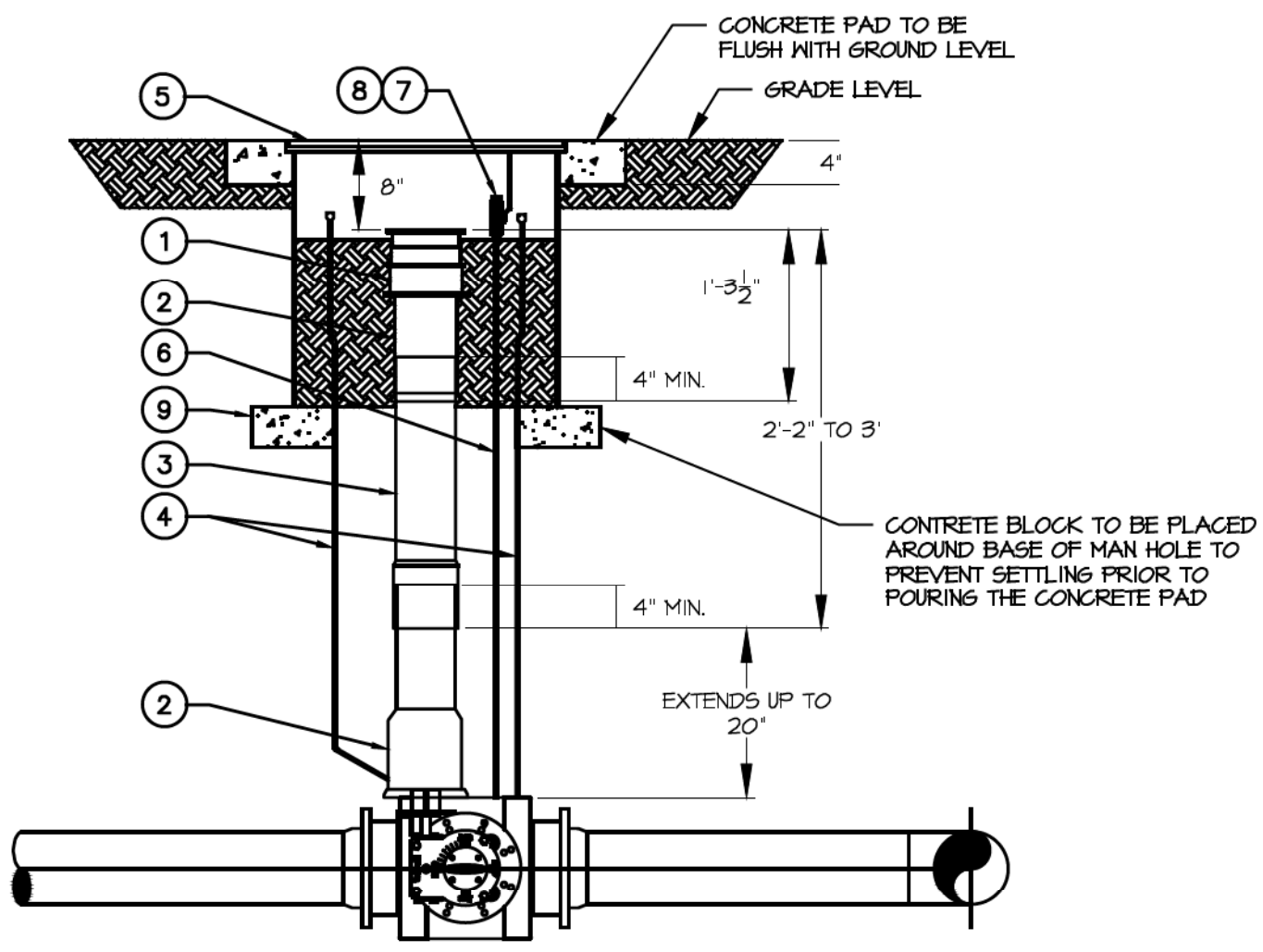

NOTES:
 1) MUST HAVE A 4" OVERLAP JOINING EXTENSION WITH VALVE BOX.
 2) USE TOP AND BOTTOM OF VALVE BOX FIRST, IF NOT LONG ENOUGH ADD EXTENSION No. P-65 TO THE MIDDLE OF ORIGINAL VALVE BOX.

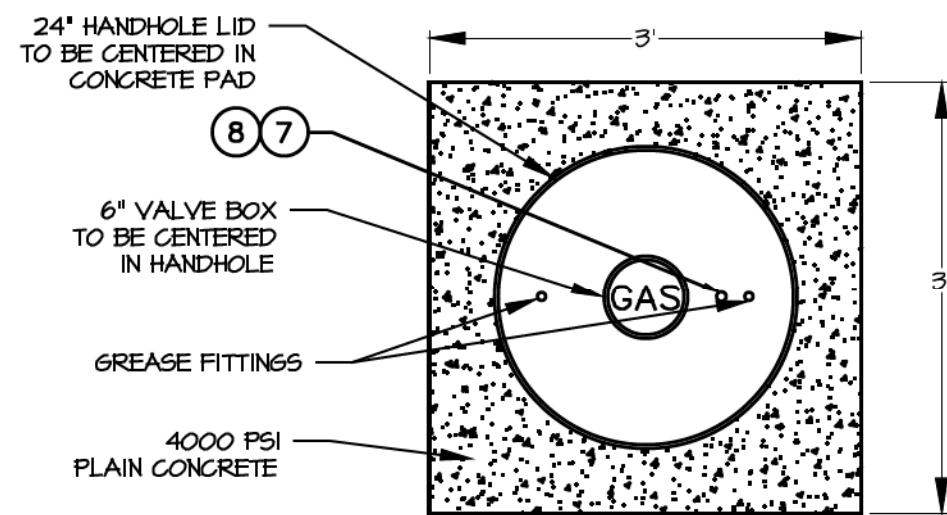

VALVE BOX DETAIL

PART #	PART NAME	DESCRIPTION
1	No. P-11B	CAST IRON LID ATTACHED TO No. 8250.
2	No. 8250	6" PLASTIC VALVE BOX. COMES IN TWO PARTS, BELL NUMBER 101.
3	No. P-65	6" PLASTIC VALVE BOX EXTENSION. IF NEEDED, INSTALL BETWEEN THE TOP AND BOTTOM PIECES OF No. 8250.
4	GREASE FITTINGS	GREASE FITTINGS ATTACHED TO THE VALVE AND EXTENDS INTO THE PEMCO VALVE BOX.
5	PEMCO 24" VALVE BOX	PEMCO 24" X 24" ROUND VALVE BOX.
6	BODY BLEED TUBING	TUBING TIES INTO THE BACK SIDE OF THE VALVE.
7	APOLLO 1/2" BALL VALVE	1/2" BALL VALVE FOR BODY BLEED.
8	1/2" PLUG	1/2" PLUG ATTACHED TO THE BALL VALVE.
9	CONCRETE BLOCK	COMMON 4" X 8" X 16" OR EQUIVALENT BLOCK.

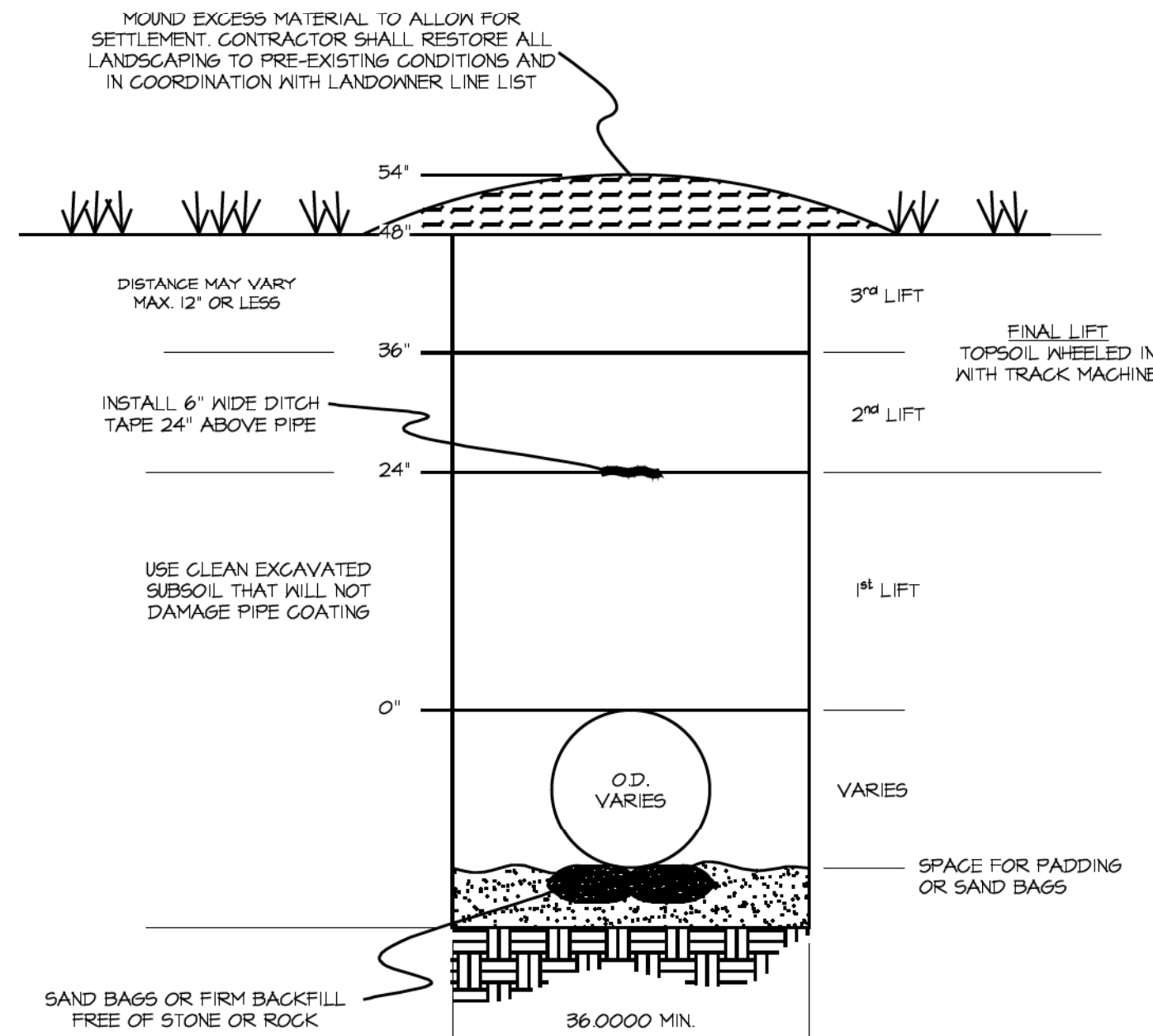

NOTES:
 1. BELL HOLES AND BORE PITS TO BE MECHANICALLY TAMPED ONCE 24-INCHES OF BACKFILL MATERIAL COVERS PIPE.
 2. CONTRACTOR SHALL FOLLOW STATE OR LOCAL REQUIREMENTS FOR BACKFILL WITHIN STATE OR LOCAL RIGHT-OF-WAY OR RAILROAD PROPERTY.

TRENCH BACK FILL DETAIL FOR AGRICULTURAL OR RESIDENTIAL APPLICATION
 N.T.S.

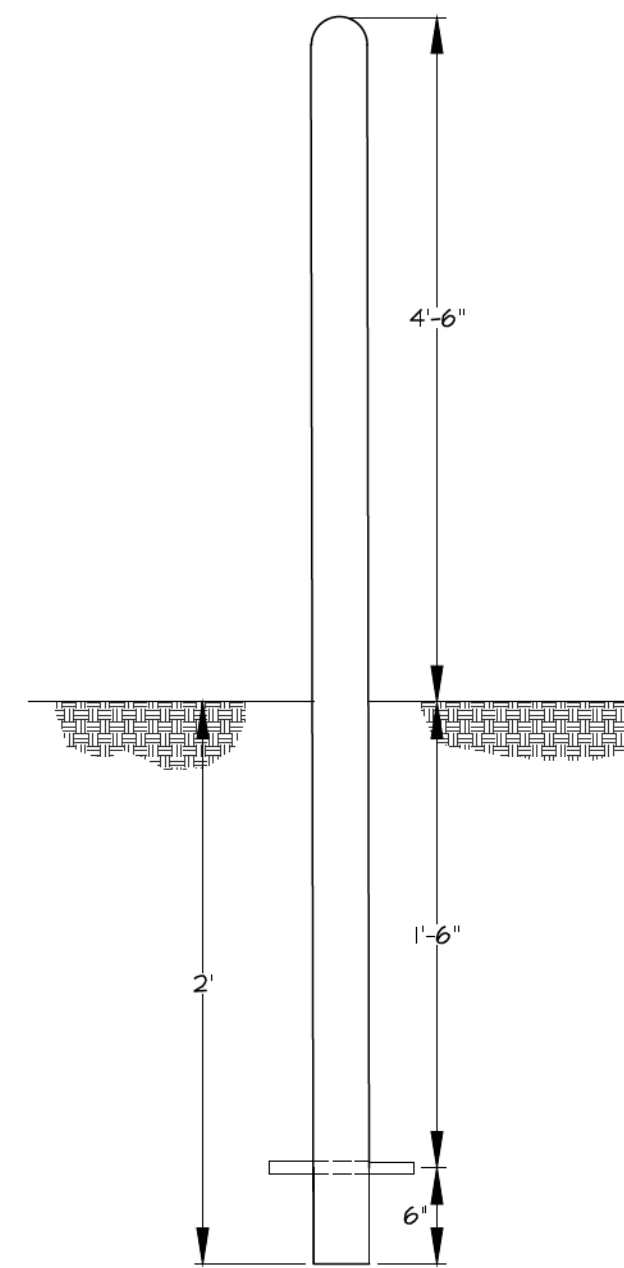

NOTES:
 1. COMPANY TO FURNISH MARKER POSTS, TYPICALLY 3-1/2" x 6'-6" POLY PIPE WITH 3/4" x 4" ANCHOR BAR 6" FROM BOTTOM.
 2. POLY PIPE TO BE PLACED 2'-0" UNDER FINISH GRADE WITH 4'-6" OF POLY PIPE EXPOSED ABOVE GROUND.
 3. LOCATION OF PIPELINE MARKER POSTS TO BE PROVIDED BY ESNG.
 4. PIPE LINE MARKERS SHOULD INCLUDE "CAUTION GAS PIPELINE DO NOT DIG" IN ADDITION THE 811 LOGO AND NUMBER SHOULD BE ABOVE THE EASTERN SHORE NATURAL GAS LOGO.

PIPELINE MARKER POST
 NOT TO SCALE

Material Schedule			
Item #	Quantity	Units	Description
1	1	EA	SERIES 6033116 UTILITY MARKER W/ ESNG GRAPHIC #2622, 3" OD X 72" LENGTH, BISON 11-TERMINAL STAINLESS STEEL TEST STATION AND CAP #DTCUL30385YEL
2	40	FT	WIRE No. 8 AWG STRANDED COPPER BLACK, THHN
4	2	EA	THERMITE CARTRIDGE No. 15 MAX. OR PIN BRAZE

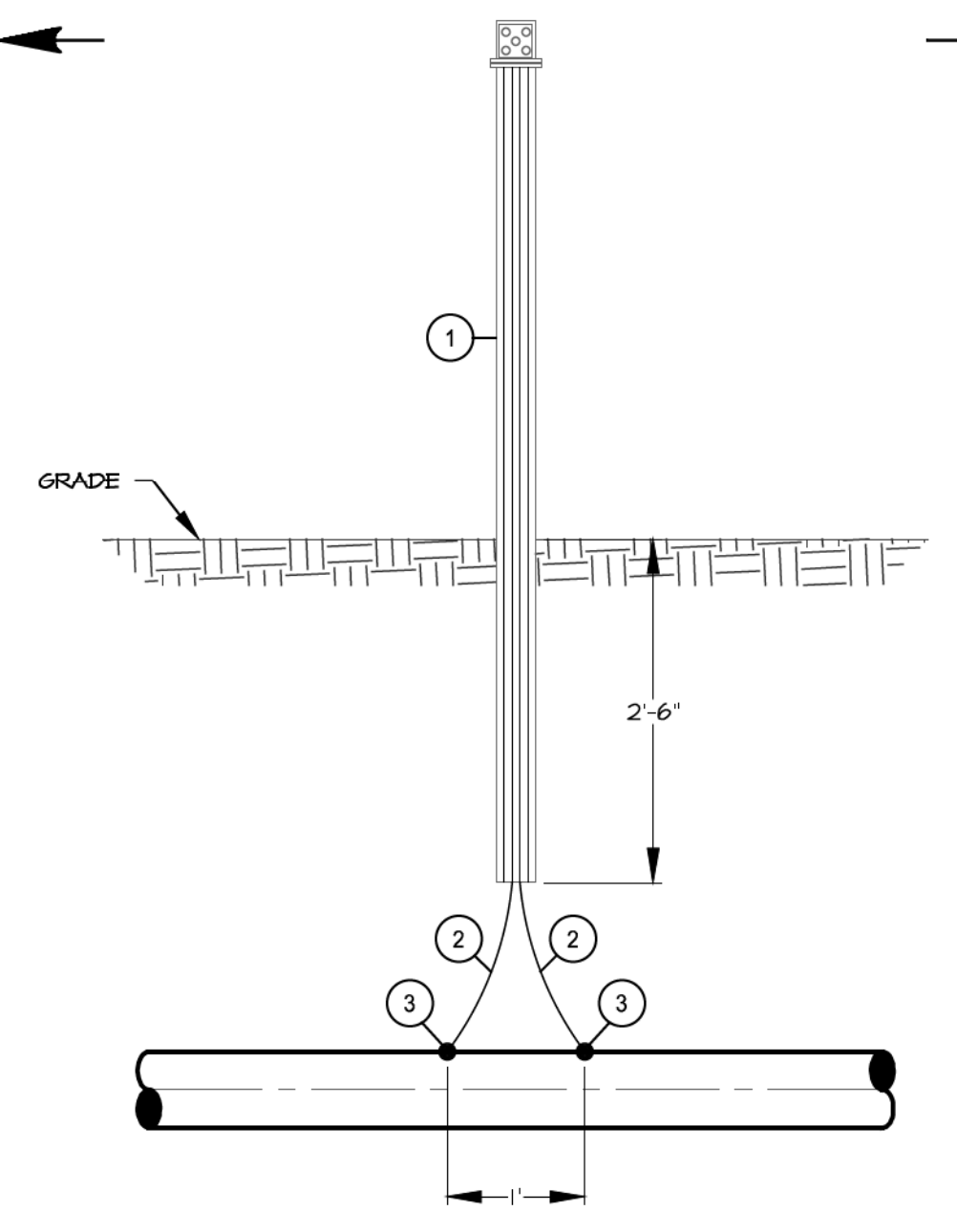

NOTES:
 1) No. 8 AWG STRANDED COPPER WIRES THERMITE WELDED (MAX SIZE No. 15 CARTRIDGE) OR PIN BRAZED TO STEEL CARRIER PIPE.
 2) WELD TO BE COATED WITH 2-PART EPOXY, 3-PART MAX TAPE OR COMPANY APPROVED EQUIVALENT.
 3) ALL TEST WIRES TO EXTEND 2' BEYOND TOP OF TEST BOX.
 4) WIRES TO BE PLACED AT A NOMINAL DEPTH OF 3' FROM GRADE AND PROTECTED BY 3/4" CONDUIT PROVIDED BY ESNG.

TEST STATION TS-02A

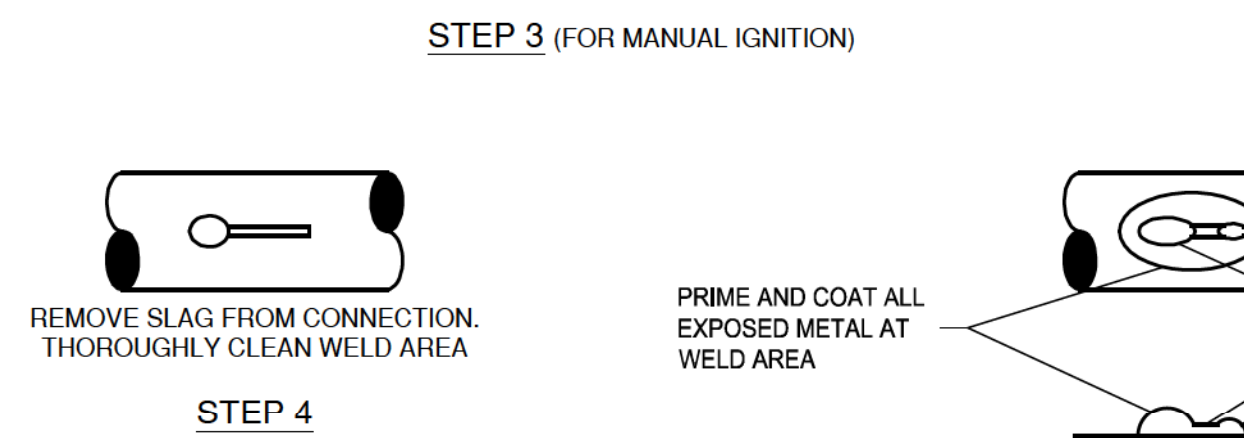
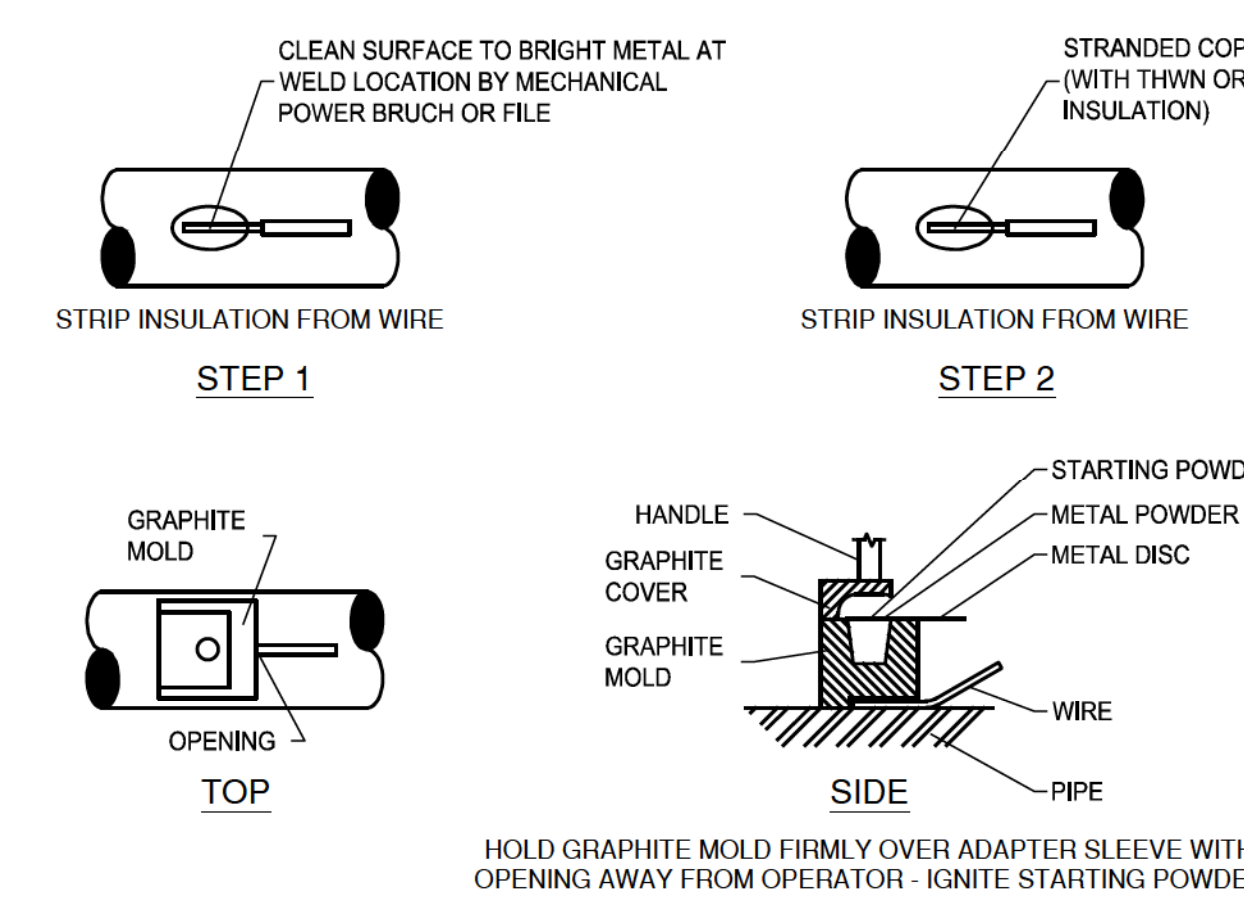

NOTE:
 1. THERMITE WELDS MADE TO GAS MAIN SHALL BE COATED WITH TWO PART EPOXY OR THREE PART WAX TAP OR APPROVED EQUAL.
 2. REPAIR PIPE COATING IN ACCORDANCE WITH MANUFACTURERS RECOMMENDATIONS.

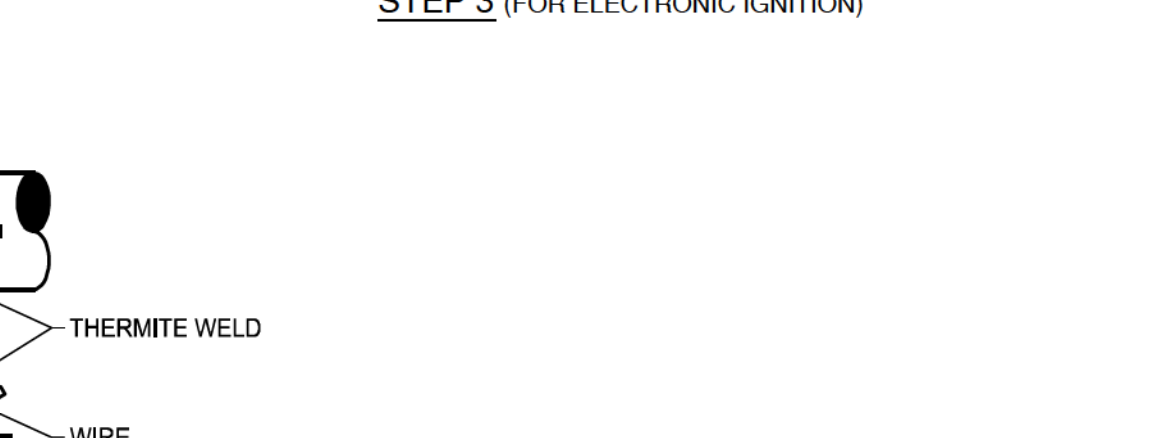
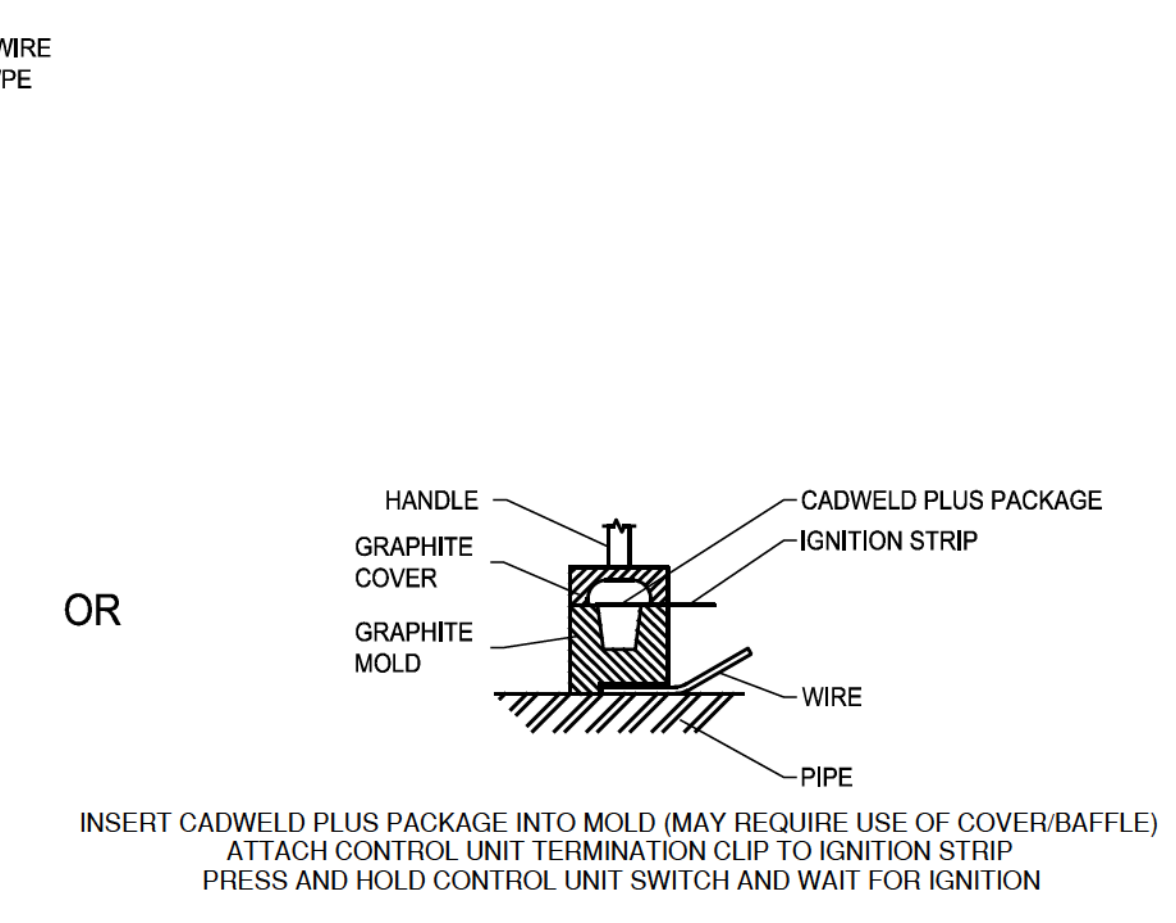

THERMITE WELD DETAILS

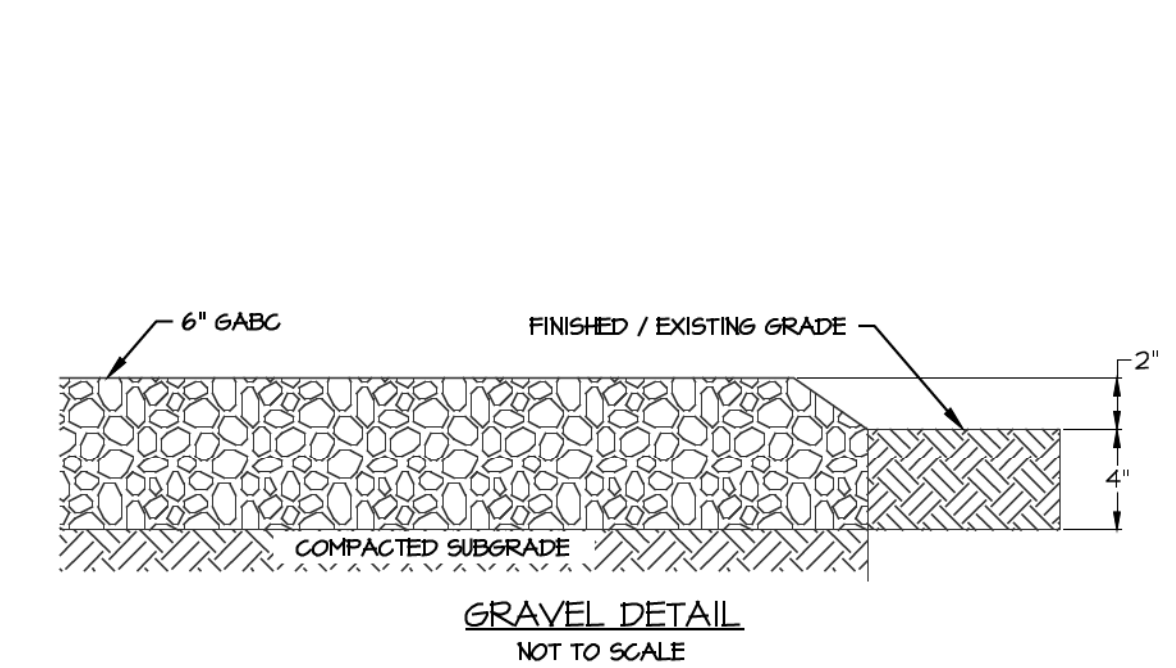
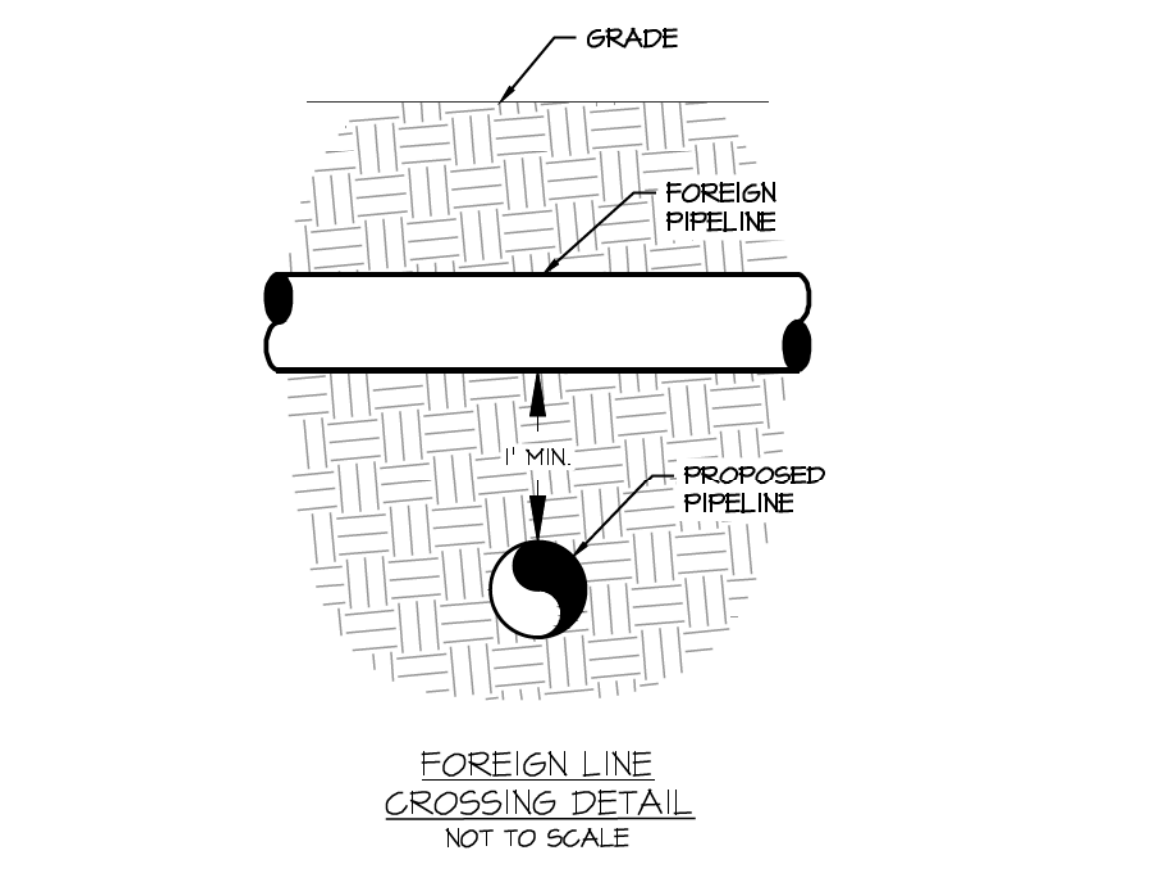

GRAVEL DETAIL
 NOT TO SCALE

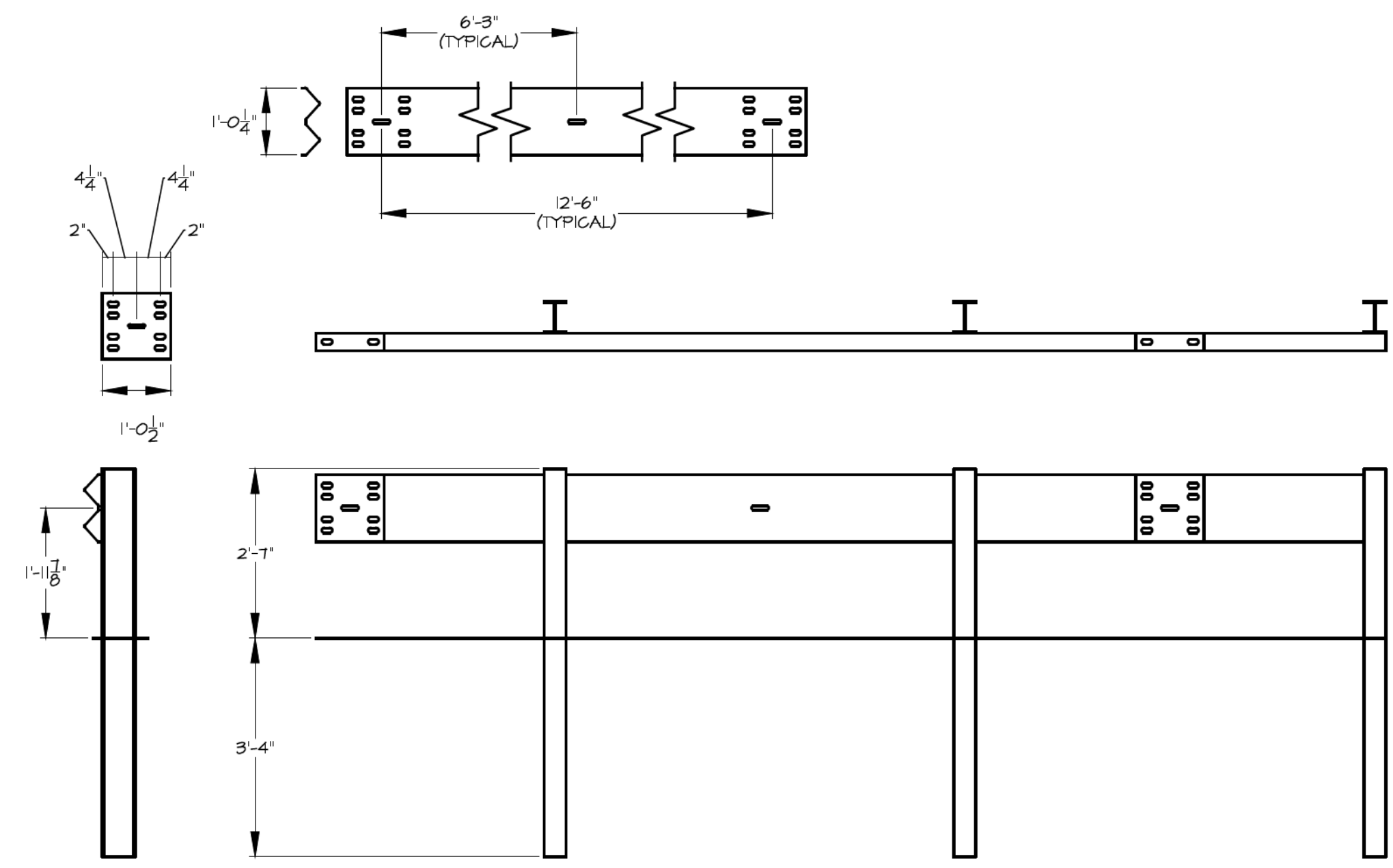

GUARDRAIL DETAIL
 ALSO SEE DEDOT 2014 STANDARDS MANUAL B-1 GUARDRAIL APPLICATIONS



REVISIONS			
NO.	DATE	DESCRIPTION	BY

MRA
MORRIS & RITCHIE ASSOCIATES, INC.
 ENGINEERS, PLANNERS, SURVEYORS AND LANDSCAPE ARCHITECTS
 111 RUTHAR DRIVE
 NEWARK, DE 19711
 (302) 326-2200
 MRAGTA.COM
 © 2025 MORRIS & RITCHIE ASSOCIATES, INC.

EASTERN SHORE
 NATURAL GAS
 500 ENERGY LANE, SUITE 200 DOVER, DE 19901
 TELEPHONE (302) 734-6710 • FAX (302) 734-6745

CONSTRUCTION DETAILS
6" PROPOSED PIPELINE
CAMDEN CONTROLLER
KENT COUNTY, DE

ESNG PROJECT CODE:	ES XXXX	DATE:	6/19/2026
MRA PROJECT NO:	23098	SCALE:	AS SHOWN
DESIGN/CHECK BY:	JTH/CWB	SHEET:	14 OF 18

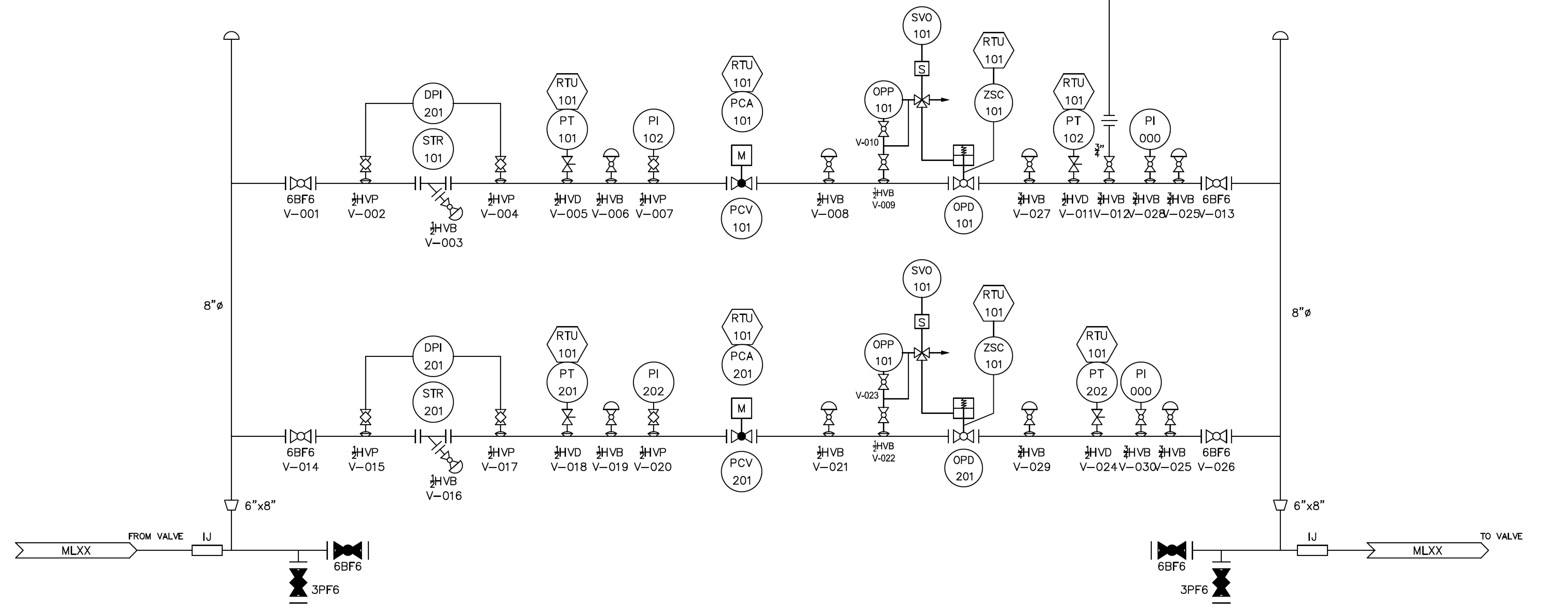
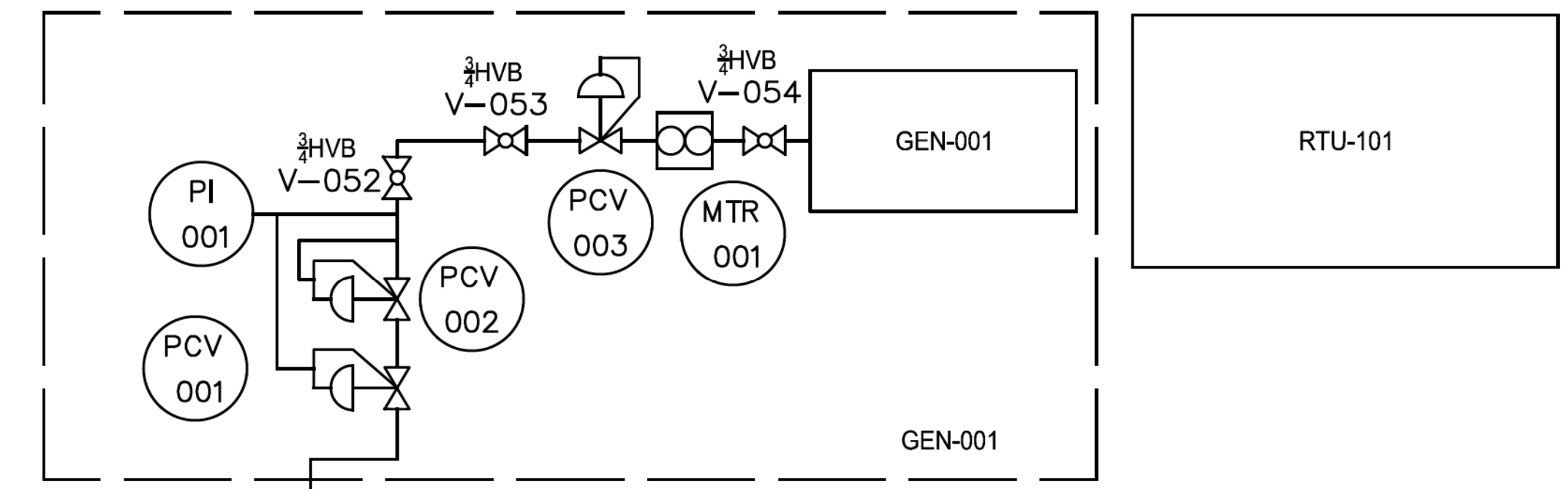

CAMDEN CONTROLLER PIPING AND INSTRUMENTATION DETAILS

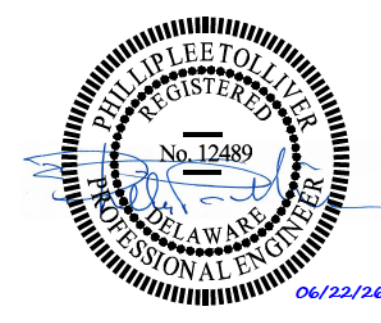

REVISIONS			
NO.	DATE	DESCRIPTION	BY

MRA
MORRIS & RITCHE ASSOCIATES, INC.
 ENGINEERS, PLANNERS, SURVEYORS AND LANDSCAPE ARCHITECTS
 111 RUTHAR DRIVE
 NEWARK, DE 19711
 (302) 326-2200
 MRAGTA.COM
 © 2025 MORRIS & RITCHE ASSOCIATES, INC.

EASTERN SHORE
 NATURAL GAS
 500 ENERGY LANE, SUITE 200 DOVER, DE 19901
 TELEPHONE (302) 734-6710 - FAX (302) 734-6745

6" PROPOSED PIPELINE CAMDEN CONTROLLER KENT COUNTY, DE			
ESNG PROJECT CODE:	ES XXXX	DATE:	6/19/2026
MRA PROJECT NO:	23098	SCALE:	N/A
DESIGN/CHECK BY:	JTH/CWB	SHEET:	15 OF 18

LINE TYPES
TABLE 1

	PRIMARY PROCESS (MAJOR)
	SECONDARY PROCESS (MINOR)
	PACKAGE/SKID LIMITS
	INSTRUMENT OR PROCESS
	PNEUMATIC SIGNAL
	ELECTRIC SIGNAL
	HYDRAULIC SIGNAL
	CAPILLARY TUBE
	LOGIC-SYSTEM LINK SOFTWARE OR DATA LINK

LINE TYPES
TIE-IN PROCEDURE

	PRESSURIZED (GREEN)
	DE-PRESSURIZED (RED)
	LOCATION (CYAN)
	REMOVING (RED)

VALVE POSITION

	OPEN
	CLOSED

VALVE CONNECTION DESIGNATIONS

	THREADED
	FLANGED
	SOCKET WELD
	BUTT WELD

VALVE SYMBOL SIZES
TABLE 3

	> 2" PIPE SIZE
	< 2" PIPE SIZE

CONTINUATION ARROWS
TABLE 4

	UNIDIRECTIONAL
	BIDIRECTIONAL

PRIMARY FLOW DEVICES
TABLE 5

	FLOW SIGHT GLASS
	ROTAMETER
	ORIFICE PLATE IN QUICK-CHANGE FITTING
	VORTEX METER
	TURBINE METER
	AVERAGING PITOT TUBE (ANNUBAR)
	PITOT TUBE OR PITOT-VENTURI TUBE
	MASS FLOW (CORIOLIS)
	POSITIVE DISPLACEMENT METER
	ULTRASONIC METER
	FLOW CONDITIONER
	VENTURI TUBE
	FLOW NOZZLE
	RESTRICTION ORIFICE FLANGE SET

VALVE & ACTUATOR SYMBOLS

	GATE VALVE (UNDEFINED VALVE)
	BALL VALVE
	PLUG VALVE
	GLOBE VALVE
	CHECK VALVE
	NEEDLE VALVE
	BUTTERFLY VALVE
	EXCESS FLOW VALVE
	ANGLE VALVE
	3-WAY VALVE
	4-WAY VALVE
	DOUBLE BLOCK & BLEED VALVE
	BLOCK & BLEED VALVE (INSTRUMENT)
	PRESSURE RELIEF VALVE
	PRESSURE RELIEF VALVE
	VACUUM RELIEF VALVE
	PRESSURE AND VACUUM RELIEF VALVE
	SHUTTLE VALVE
	3-WAY SOLENOID OPERATED VALVE VENTS WHEN DE-ENERGIZED
	3-WAY SOLENOID OPERATED VALVE WITH MANUAL RESET
	PILOT OPERATED RELIEF VALVE
	PILOT OPERATED RELIEF VALVE
	PISTON OPERATED VALVE, SINGLE ACTING
	PISTON OPERATED VALVE, DOUBLE ACTING
	DOUBLE ACTING PISTON, SPRING RETURN
	SOLENOID ACTUATED VALVE
	MOTOR ACTUATED VALVE
	GAS ACTUATED VALVE
	GAS-HYDRAULIC ACTUATED VALVE
	ELECTRO-HYDRAULIC ACTUATED VALVE
	AIR-HYDRAULIC ACTUATED VALVE
	DIAPHRAGM ACTUATED VALVE
	DIAPHRAGM ACTUATED VALVE W/MANUAL OVERRIDE
	PRESSURE REDUCING REGULATOR W/EXTERNAL PRESSURE TAP
	BACK PRESSURE REGULATOR
	PRESSURE-REDUCING REGULATOR
	3-WAY TEMPERATURE REGULATOR SELF CONTAINED
	DIAPHRAGM ACTUATED VALVE W/POSITIONER
	3-WAY PILOT OPERATED VALVE VENTS WHEN DE-ENERGIZED
	MOTOR OPERATOR / CONTROL VALVES

MANUAL VALVE IDENTIFICATION
TABLE 7

VALVES 2" AND ABOVE

VALVES BELOW 2"

Sequential Number V-001...V-050

Rating, Connection Type, Valve Type, Size

Hand Valve, Valve Type, Size (No Sequence Number)

VALVE TYPE CONNECTION TYPE RATING

CODE	TYPE	CODE	TYPE	CODE	TYPE
A	ANGLE	F	FLANGED	1	ANSI 150#
B	BALL	W	BUTTWELD	3	ANSI 300#
C	CHECK	T	THREADED	6	ANSI 600#
D	DOUBLE BLOCK/BLEED	Z	SOCKETWELD	9	ANSI 900#
F	BUTTERFLY	X	WELD X FLANGE	15	ANSI 1500#
G	GLOBE	AA	WOG 600#		
N	NEEDLE	A	WOG 800#		
P	PLUG	B	WOG 2000#		
S	SOLENOID	C	WOG 3000#		
U	GATE / UNDEFINED	D	WOG 6000#		
Z	SPECIAL				

NOTES:
1. REFERENCE ISA STANDARD, "INSTRUMENTATION SYMBOLS AND IDENTIFICATION", ANSI/ISA-55.1 (LATEST EDITION).
2. REFERENCE NISOURCE GAS TRANSMISSION & STORAGE PIPING MATERIAL LINE CLASS SPECIFICATIONS FOR COMPLETE SPECIFICATION IDENTIFICATION LISTING. (SWEET NATURAL GAS SERVICE ONLY).

MISCELLANEOUS SYMBOLS
TABLE 8

	REDUCER (CONCENTRIC)
	REDUCER (ECCENTRIC)
	SWAGE
	FLANGE
	BLIND FLANGE (DRILL & TAP)
	UNION
	INSULATING FLANGES
	INSULATING UNION
	INSULATING JOINT
	SPECTACLE BLIND (OPEN)
	SPECTACLE BLIND (CLOSED)
	WELD CAP
	THREADED CAP
	THREADED PLUG (ON VALVE)
	HOSE CONNECTION
	PIG SIGNAL
	CLAPPER TYPE VENT (RAIN CAP)
	BLOW OFF CLOSURE
	GOOSE NECK VENT
	SPACER
	FILTER OR BASKET STRAINER
	STRAINER ("Y" TYPE)
	STRAINER ("T" TYPE)
	EXPANSION JOINT
	EXPANSION LOOP
	FLEXIBLE CONNECTION
	TEST RING W/VALVE (BLEED RING)
	BLANKING CAP
	NOZZLE
	MULTIPLE COUPLINGS AROUND PIPE
	COUPLING
	PIPE TAP (O-LET)
	SPHERICAL TEE
	FLOW ARROW
	TYPICAL INSTRUMENT VALVE

HEAT TRACE TYPE
TABLE 14

CODE	TYPE
E	ELECTRICAL TRACE
O	HOT OIL TRACE
G	GLYCOL TRACE
S	STEAM TRACE
N	NONE USED

TS = TEMPORARY STRAINER
CS = CONE STRAINER

THICKNESS
INSULATION FUNCTION & MATERIAL (TABLES 12 & 13)
TYPE INSULATED & HEAT TRACED PIPE
HEAT TRACE TYPE (TABLE 14) [ELECTRICAL TRACE SHOWN]

LINE NUMBER IDENTIFICATION
TABLE 9

PIPE SIZE: 20"-GMC1-007-2FFE

SERVICE CODE: (TABLE 10)
SPEC ID: (TABLE 11)

HEAT TRACE TYPE (TABLE 14)
INSULATION MATERIAL (TABLE 12)
INSULATION THICKNESS (TABLE 13)
LINE SEGMENT NUMBER

LINE NUMBER EXAMPLES
TABLE 15

20"-GMC1-007-2FFE

20"-GMC1-008-2FFE

20"-GMC1-007-2FFE

END OF LINE NUMBER DESIGNATION (LINE NUMBER BREAK)

SERVICE CODES
TABLE 10

CODE	SERVICE	CODE	SERVICE
AC	AIR, COMBUSTION	MD	METHANOL, DRIP
AI	AIR, INSTRUMENT	MI	METHANOL, INJECTION
AP	AIR, PLANT	OH	OIL, HYDRAULIC
AS	AIR, STARTING	OI	OIL, INJECTION
AU	AIR, UTILITY	OL	OIL, LUBRICATING
		OS	OIL, SEALING
C	CONDENSATE	SL	STEAM SERVICE
DL	DEHY, LINE	SS	SANITARY SEWER
EP	EXHAUST PIPING	WC	WATER, COOLING
FD	FLUID, DRAIN	WD	WATER, DRAIN
FP	FLUID, PIPELINE LIQUIDS	WH	WATER, HEATING
		V	VENT

SPEC ID EXAMPLES
TABLE 11

SPECIFICATION NUMBER	CODE	DESIGN TEMPERATURE	DESIGN PRESSURE	NOTE 2
B	B31.8	-20° to 140° F	275 PSIG	CL 150 (C.S)
C	B31.8	-20° to 130° F	720 PSIG	CL 300 (C.S)
H	B31.8	-20° to 200° F	1350 PSIG	CL 600 (C.S)
J1	B31.3	300° F	175 PSIG	CL 150 (S.S)
J3	B31.3	-20° to 130° F	500 PSIG	CL 300 (S.S)
K	IPC	100° F	180 PSIG	CL 150 (GALV)
L	IPC	100° F	180 PSIG	CL 150 (PVC)

INSULATION FUNCTION
TABLE 12

CODE	FUNCTION
C	COLD CONSERVATION
F	FREEZE PROTECTION
G	GENERAL PURPOSE HEAT CONSERVATION
H	PERSONNEL PROTECTION
P	SOUND ATTENUATION

INSULATION MATERIAL
TABLE 13

CODE	MATERIAL
C	CALCIUM SILICATE
F	FIBERGLASS
G	CELLULAR GLASS
M	(FOAM GLASS)
O	MINERAL WOOL
U	OTHER (SPECIFY)
	URETHANE

LINE SEGMENT NUMBER
TABLE 16

NUMBER	SERVICE
100-199	GB- GAS BYPASS GD- GAS DISCHARGE GS- GAS SUCTION
200-299	GN- GAS NATURAL GV- GAS VENT
300-399	GB- GAS BYPASS (FUEL GAS) GF- GAS FUEL GV- GAS VENT (FUEL GAS)
400-499	OL- OIL LUBE VE- VIBRATION ELEMENT VS* - RESERVED FOR SHUTDOWN DEVICE
500-599	AI- AIR INSTRUMENT AB- AIR BYPASS AS- AIR STARTING AU- AIR UTILITY AP- AIR PLANT AV- AIR VENT
600-699	WC- WATER COOLING WP- WATER PIPING
700-799	FD- FLUID DRAIN FP- FLUID P/L LIQUIDS

INSTRUMENT ABBREVIATIONS
(INSIDE INSTRUMENT BALLOONS)

AA*	ANALYSIS ALARM	AG	ABOVE GROUND
AC	ANALYSIS CONTROLLER (SAMPLER)	ALM	ALARM
AE	ANALYSIS ELEMENT (SAMPLER)	APU	AUXILIARY POWER UNIT
AI	ANALYSIS INDICATOR	A/M	AUTO-MANUAL SELECTOR
AIC	ANALYSIS INDICATING CONTROLLER	AS	AIR SUPPLY
AIS*	ANALYSIS INDICATING SWITCH	ASV	ANTI-SURGE VALVE
AIT	ANALYSIS INDICATING TRANSMITTER	ASC	ANTI-SURGE CONTROLLER
AP	ANALYSIS POINT (CHROMATOGRAPH)	ATM	ATMOSPHERE
AR	ANALYSIS RECORDER	ATS	AUTO TRANSFER SWITCH
AS*	ANALYSIS SWITCH	BD	BLOW DOWN
AT	ANALYSIS TRANSMITTER (CHROMATOGRAPH)	BF	BLIND FLANGE
AV	ANALYSIS CONTROL VALVE	BIF	BURIED ISOLATING FLANGE
AV*	ANALYSIS VALVE	BG	BELOW GROUND
BA*	BURNER ALARM	CC	CORROSION COUPON
BE	BURNER ELEMENT	CE	CORROSION COUPON/PROBE
BS	BURNER SWITCH	CL	CLOSE
BT	BURNER THERMOCOUPLE	CS	CONE STRAINER
ES*	VOLTAGE INDICATOR	CSC	CAR SEAL CLOSED
ES*	VOLTAGE SWITCH	CSD	CAR SEAL OPEN
FA*	FLOW ALARM	DE	DE-ENERGIZE
FC	FLOW CONTROL VALVE	DR	DRYER REGULATOR
FCV	FLOW CONTROL VALVE	EFM	ELECTRONIC FLOW MEASUREMENT
FE	FLOW ELEMENT	ELEV	ELEVATION
FFC	FLOW RATIO CONTROLLER	EL	ELECTRIC SUPPLY
FI	FLOW INDICATOR	ESD	EMERGENCY SHUTDOWN
FIC	FLOW INDICATING CONTROLLER	(F)	FURNISHED WITH EQUIPMENT
FIT	FLOW INDICATING TRANSMITTER	FB	FULL BORE
FLP	FAIL LAST POSITION	FI	FAIL INTERMEDIATE
FO	FLOW RESTRICTION ORIFICE	FL	FLANGED END
FQ	FLOW TOTALIZER/FLOW COMPUTER	FC	FAIL CLOSED
FQI	FLOW TOTALIZING INDICATOR	FO	FAIL OPEN
FQI*	FLOW TOTALIZING SWITCH	FL	FAIL LAST
FR*	FLOW RECORDING CONTROL VALVE	F/S	FAST SLOW SELECTOR
FRCV	FLOW RECORDING CONTROL VALVE	GOV	GAS OPERATED VALVE
FS*	FLOW SWITCH	GS	GAS SUPPLY
FS*	FLOW SWITCH	LC	LEVEL CONTROLLER
FT	FLOW TRANSMITTER	LCV	LEVEL CONTROL VALVE
FV	FLOW VALVE	LG	LEVEL GAUGE GLASS
FV	FLOW STRAIGHTENING VANE	LI	LEVEL INDICATOR (OTHER THAN L6)
FY	FLOW RELAY	LIC	LEVEL INDICATING CONTROLLER
FZ	FLOW COMPUTING RELAY (MASS)	LR	LEVEL RECORDER
HC	HAND CONTROLLER	LS*	LEVEL SWITCH
HCV	HAND CONTROL VALVE	LT	LEVEL TRANSMITTER
HS	HAND SWITCH	LV	LEVEL VALVE
HV	HAND VALVE	MA*	MOISTURE ALARM
GU	INSTRUMENT GAS SUPPLY COLUMN	MC	MOISTURE CONTROLLER
L*	LEVEL DEVICE	ME	MOISTURE ELEMENT
LC	LEVEL CONTROLLER	MI	MOISTURE INDICATOR
LCV	LEVEL CONTROL VALVE	MS	MOISTURE RECORDER
LG	LEVEL GAUGE GLASS	MS*	MOISTURE SWITCH
LI	LEVEL INDICATOR (OTHER THAN L6)	MT	MOISTURE ANALYZER/TRANSMITTER
LIC	LEVEL INDICATING CONTROLLER	OPPV	OVER PRESSURE PROTECTION VALVE
LR	LEVEL RECORDER	OSP	OVER SPEED SWITCH
LS*	LEVEL SWITCH	OSS*	OVER SPEED SWITCH
LT	LEVEL TRANSMITTER	PA*	PRESSURE ALARM
LV	LEVEL VALVE	PC	PRESSURE CONTROLLER
MA*	MOISTURE ALARM	PCV	PRESSURE CONTROL VALVE (SELF-CONTAINED)
MC	MOISTURE CONTROLLER	PDIA	PRESSURE DIFFERENTIAL INDICATING ALARM
ME	MOISTURE ELEMENT	PDCV	PRESSURE DIFFERENTIAL CONTROL VALVE
MI	MOISTURE INDICATOR	PD	PRESSURE DIFFERENTIAL INDICATOR
MS	MOISTURE RECORDER	PDIC	PRESSURE DIFFERENTIAL INDICATING CONTROLLER
MS*	MOISTURE SWITCH	POIS	PRESSURE DIFFERENTIAL INDICATING SWITCH
MT	MOISTURE ANALYZER/TRANSMITTER	PDR	PRESSURE DIFFERENTIAL RECORDER
OPPV	OVER PRESSURE PROTECTION VALVE	PDT	PRESSURE DIFFERENTIAL TRANSMITTER
OSP	OVER SPEED SWITCH	PDI	PRESSURE DIFFERENTIAL INDICATING TRANSMITTER
OSS*	OVER SPEED SWITCH	PEV	PRESSURE EQUALIZATION VALVE
PA*	PRESSURE ALARM	PI	PRESSURE INDICATOR
PC	PRESSURE CONTROLLER	PIC	PRESSURE INDICATING CONTROLLER
PCV	PRESSURE CONTROL VALVE (SELF-CONTAINED)	PIT	PRESSURE INDICATING TRANSMITTER
PDIA	PRESSURE DIFFERENTIAL INDICATING ALARM	PR	PRESSURE RECORDER
PDCV	PRESSURE DIFFERENTIAL CONTROL VALVE	PRC	PRESSURE RECORDING CONTROLLER
PD	PRESSURE DIFFERENTIAL INDICATOR	PRV	PRESSURE REGULATING VALVE
PDIC	PRESSURE DIFFERENTIAL INDICATING CONTROLLER	PS*	PRESSURE SWITCH
POIS	PRESSURE DIFFERENTIAL INDICATING SWITCH	PSE	PRESSURE SAFETY HEAD
PDR	PRESSURE DIFFERENTIAL RECORDER	PSV	PRESSURE SAFETY RELIEF VALVE
PDT	PRESSURE DIFFERENTIAL TRANSMITTER	PSV	PRESSURE SAFETY RELIEF VALVE
PDI	PRESSURE DIFFERENTIAL INDICATING TRANSMITTER	PT	PRESSURE TRANSMITTER
PEV	PRESSURE EQUALIZATION VALVE	PV	PRESSURE CONTROL VALVE
PI	PRESSURE INDICATOR	PY	PRESSURE RELAY
PIC	PRESSURE INDICATING CONTROLLER	RSI	REMOTE SHUT-IN
PIT	PRESSURE INDICATING TRANSMITTER	RSI*	REMOTE SHUT-IN
PR	PRESSURE RECORDER	SDV	SHUTDOWN VALVE
PRC	PRESSURE RECORDING CONTROLLER	SE	SPEED ELEMENT (TACHOMETER PICK-UP)
PRV	PRESSURE REGULATING VALVE	SE*	SPEED SWITCH
PS*	PRESSURE SWITCH	ST	SPEED TRANSMITTER
PSE	PRESSURE SAFETY HEAD	STR	STRAINER
PSV	PRESSURE SAFETY RELIEF VALVE	SVC	SOLENOID VALVE CLOSED
PSV	PRESSURE SAFETY RELIEF VALVE	SVO	SOLENOID VALVE OPEN
PT	PRESSURE TRANSMITTER	TA*	TEMPERATURE ALARM
PV	PRESSURE CONTROL VALVE	TC	TEMPERATURE CONTROLLER
PY	PRESSURE RELAY	TCV	TEMPERATURE CONTROL VALVE (SELF-CONTAINED)
RSI	REMOTE SHUT-IN	TDI	TEMPERATURE DIFFERENTIAL INDICATOR
RSI*	REMOTE SHUT-IN	TE	TEMPERATURE ELEMENT (WITH THERMOWELL)
SDV	SHUTDOWN VALVE	TI	TEMPERATURE INDICATOR (WITH THERMOWELL)
SE	SPEED ELEMENT (TACHOMETER PICK-UP)	TI	TEMPERATURE INDICATING CONTROLLER
SE*	SPEED SWITCH	TICV	TEMPERATURE INDICATING CONTROL VALVE
ST	SPEED TRANSMITTER	TR	TEMPERATURE RECORDER
STR	STRAINER	TRC	TEMPERATURE RECORDING CONTROLLER
SVC	SOLENOID VALVE CLOSED	TRCV	TEMPERATURE RECORDING CONTROL VALVE
SVO	SOLENOID VALVE OPEN	TS*	TEMPERATURE SWITCH
TA*	TEMPERATURE ALARM	TT	TEMPERATURE TRANSMITTER
TC	TEMPERATURE CONTROLLER	ITT	TEMPERATURE INDICATING TRANSMITTER
TCV	TEMPERATURE CONTROL VALVE (SELF-CONTAINED)	TV	TEMPERATURE CONTROL VALVE
TDI	TEMPERATURE DIFFERENTIAL INDICATOR	TW	TEMPERATURE TEST CONNECTION (THERMOWELL)
TE	TEMPERATURE ELEMENT (WITH THERMOWELL)	VA*	VIBRATION ALARM
TI	TEMPERATURE INDICATOR (WITH THERMOWELL)	VE	VIBRATION ELEMENT
TI	TEMPERATURE INDICATING CONTROLLER	VS*	RESERVED FOR SHUTDOWN DEVICE
TICV	TEMPERATURE INDICATING CONTROL VALVE	XA*	ANNUNCIATOR POINT
TR	TEMPERATURE RECORDER	XI	PIG PASSAGE INDICATOR
TRC	TEMPERATURE RECORDING CONTROLLER	XII	PIG SIG INDICATOR
TRCV	TEMPERATURE RECORDING CONTROL VALVE	XS	DIGITAL PROGRAMMABLE SWITCH TO SPECIAL RELAY (USUALLY A SOLENOID)
TS*	TEMPERATURE SWITCH	XY	SPECIAL RELAY (USUALLY A SOLENOID) DEVICE: I/P, SOV, RELAY, ETC.
TT	TEMPERATURE TRANSMITTER	ZA*	POSITION ALARM (MOTION)
ITT	TEMPERATURE INDICATING TRANSMITTER	ZE	POSITION DETECTOR (MOTION)
TV	TEMPERATURE CONTROL VALVE	ZI	POSITION INDICATOR LAMP (VALVE CLOSED)
TW	TEMPERATURE TEST CONNECTION (THERMOWELL)	ZIC	POSITION INDICATOR LAMP (VALVE OPEN)
VA*	VIBRATION ALARM	ZS*	POSITION SWITCH (MOTION)
VE	VIBRATION ELEMENT	ZSC	POSITION INDICATOR SWITCH (VALVE CLOSED)
VS*	RESERVED FOR SHUTDOWN DEVICE	ZSO	POSITION INDICATOR SWITCH (VALVE OPEN)
XA*	ANNUNCIATOR POINT	ZT	POSITION TRANSMITTER
XI	PIG PASSAGE INDICATOR		
XII	PIG SIG INDICATOR		
XS	DIGITAL PROGRAMMABLE SWITCH TO SPECIAL RELAY (USUALLY A SOLENOID)		
XY	SPECIAL RELAY (USUALLY A SOLENOID) DEVICE: I/P, SOV, RELAY, ETC.		
ZA*	POSITION ALARM (MOTION)		
ZE	POSITION DETECTOR (MOTION)		
ZI	POSITION INDICATOR LAMP (VALVE CLOSED)		
ZIC	POSITION INDICATOR LAMP (VALVE OPEN)		
ZS*	POSITION SWITCH (MOTION)		
ZSC	POSITION INDICATOR SWITCH (VALVE CLOSED)		
ZSO	POSITION INDICATOR SWITCH (VALVE OPEN)		
ZT	POSITION TRANSMITTER		

* ALARMS, SWITCHES AND ANNUNCIATORS MAY HAVE SUFFIX LETTERS AS FOLLOWS:
L DENOTES LOW ALARM
LL DENOTES LOW SHUTDOWN
H DENOTES HIGH ALARM
HH DENOTES HIGH SHUTDOWN

NOTE: IDENTIFICATION OF INSTRUMENTS NOT COVERED IN THE LISTINGS ABOVE SHALL CONFORM TO ANSI/ISA 55.1 "INSTRUMENT SYMBOLS AND IDENTIFICATION".

P&ID SYMBOLS AND LEGENDS

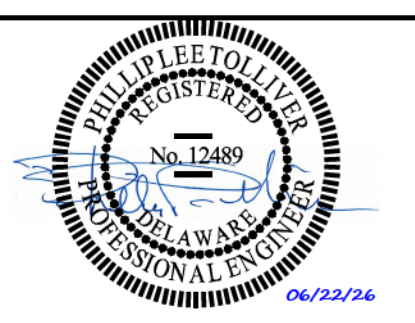

INSTRUMENT IDENTIFICATION LETTERS

TABLE 17

NOTE 1

FIRST-LETTER		SUCCEEDING-LETTERS		
MEASURED OR INITIATING VARIABLE	MODIFIER	READOUT OR PASSIVE FUNCTION	OUTPUT FUNCTION	MODIFIER
A	ANALYSIS	ALARM		
B	BURNER, COMBUSTION	USER'S CHOICE	USER'S CHOICE	USER'S CHOICE
C	USER'S CHOICE		CONTROL	CLOSE
D	USER'S CHOICE	DIFFERENTIAL		
E	VOLTAGE	SENSOR (PRIMARY ELEMENT)		
F	FLOW RATE	RATIO (FRACTION)		
G	USER'S CHOICE	GLASS, VIEWING DEVICE		
H	HAND			HIGH
I	CURRENT (ELECTRICAL)	INDICATE		
J	POWER	SCAN		
K	TIME, TIME SCHEDULE	TIME RATE OF CHANGE	CONTROL STATION	
L	LEVEL			LOW
M	USER'S CHOICE	MOMENTARY		MIDDLE, INTERMEDIATE
N	UNIT	USER'S CHOICE	USER'S CHOICE	USER'S CHOICE
O	USER'S CHOICE	ORIFICE, RESTRICTION		OPEN
P	PRESSURE, VACUUM	POINT (TEST) CONNECTION		
Q	QUANTITY	INTEGRATE, TOTALIZE		
R	RADIATION	RECORD		
S	SPEED, FREQUENCY	SAFETY	SWITCH	
T	TEMPERATURE		TRANSMIT	
U	MULTIVARIABLE		MULTIFUNCTION	MULTIFUNCTION
V	VIBRATION, MECHANICAL ANALYSIS		VALVE, DAMPER, LOUVER	
W	WEIGHT, FORCE		WELL	
X	STATION	X AXIS	UNCLASSIFIED	UNCLASSIFIED
Y	EVENT, STATE OR PRESENCE	Y AXIS	RELAY, COMPUTE, CONVERT	
Z	POSITION, DIMENSION	Z AXIS	DRIVER, ACTUATOR, UNCLASSIFIED FINAL CONTROL ELEMENT	

GENERAL INSTRUMENT OR FUNCTION SYMBOLS

TABLE 19

NOTE 1

LOCATION/ACCESSIBILITY	DISCRETE INSTRUMENTS	SHARED DISPLAY AND CONTROL (DCS)	PROGRAMMABLE LOGIC CONTROL (PLC)	COMPUTER FUNCTION (RTU)
FIELD MOUNTED				
PRIMARY LOCATION NORMALLY ACCESSIBLE TO AN OPERATOR				
PRIMARY LOCATION NORMALLY INACCESSIBLE TO AN OPERATOR				
AUXILIARY LOCATION NORMALLY ACCESSIBLE TO AN OPERATOR				
AUXILIARY LOCATION NORMALLY INACCESSIBLE TO AN OPERATOR				

L/L, H/AH-INSTRUMENTS WITH OUTPUTS FOR ALARMS, TRIPS, PILOT LIGHTS OR INTERLOCK WITH OTHER INSTRUMENT CONTROLS.

COMPUTED OR RELAY FUNCTION DESIGNATIONS

TABLE 20

FUNCTION DESIGNATIONS	CONVERT DESIGNATIONS
= HIGH SELECTOR	= EXPONENTIAL
= LOW SELECTOR	= CHARACTERIZE
= SUMMING	= EXTRACT SQUARE ROOT
= ROOT EXTRACTION	= PERCENT
= PROPORTIONAL	= BIAS (+ OR -)
= INTEGRAL	= BOOST
= DIFFERENTIAL	= GAIN
= AVERAGE	= DERIVATIVE
= INTERLOCK	= REVERSE
= CURRENT TO PNEUMATIC	

INSTRUMENT TAG NUMBER LEGEND

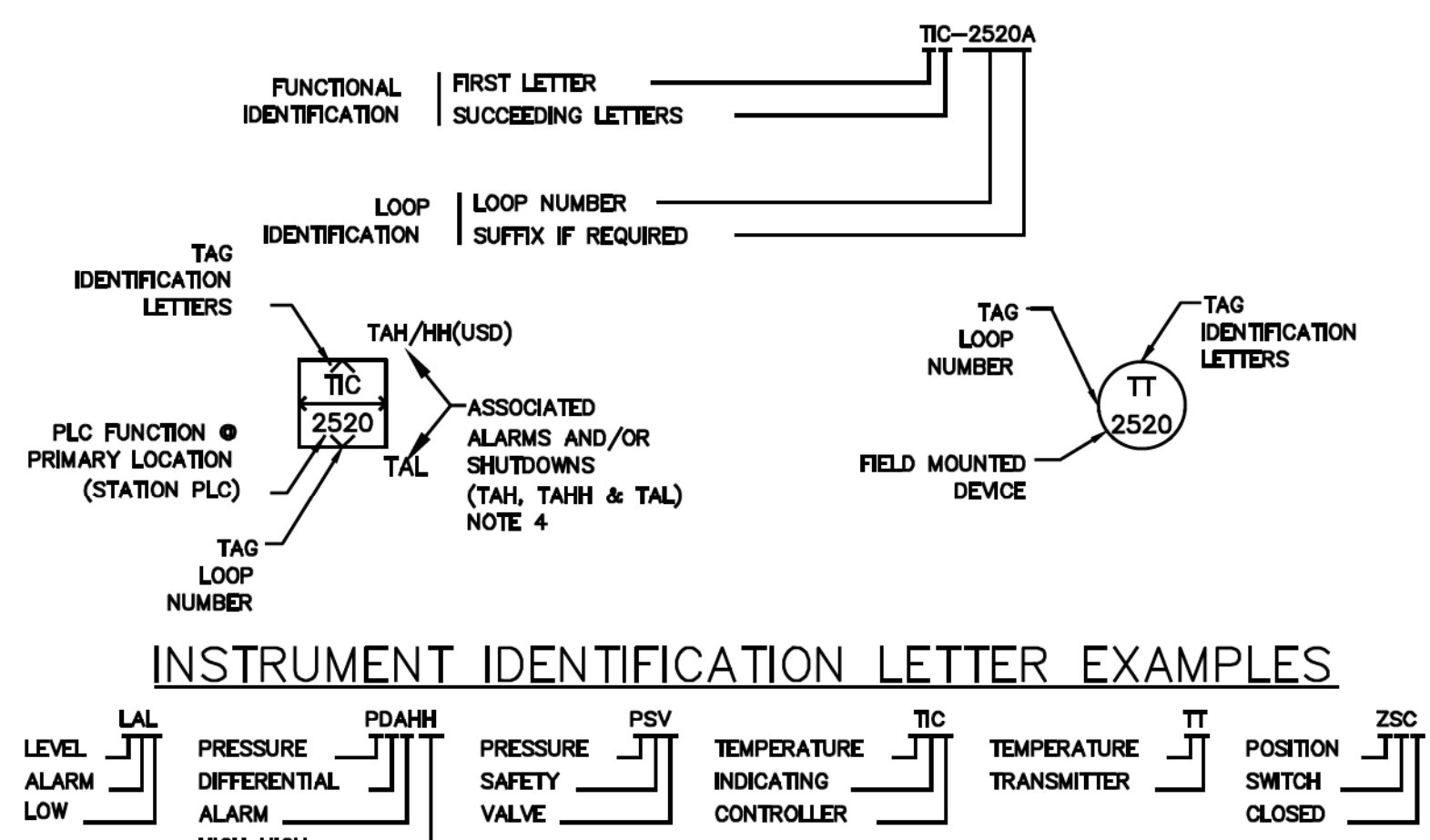

INSTRUMENT IDENTIFICATION LETTER EXAMPLES

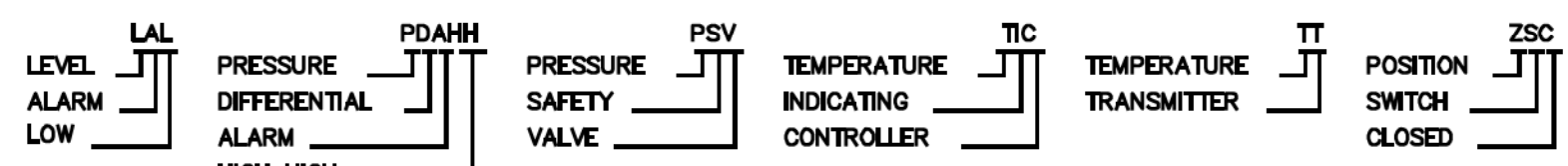

MISCELLANEOUS

TABLE 18

SHUTDOWN SYSTEM DESIGNATIONS	HAND SWITCH DESIGNATIONS
ESD FACILITY EMERGENCY SHUTDOWN	HOA F/S FAST SLOW
USD UNIT SHUTDOWN	HOA HAND OFF AUTO
SSD STATION SHUTDOWN	S/S START STOP
	L/L LEAD LAG
	L/R LOCAL REMOTE
	O/C OPEN CLOSED
	OSC OPEN STOP CLOSED

NOTES:
 1. REFERENCE ISA STANDARD, "INSTRUMENTATION SYMBOLS AND IDENTIFICATION", ANSI/ISA-S5.1 (LATEST EDITION).
 2. EQUIPMENT SYMBOLS SHOWN DO NOT COVER MAJOR ENGINEERED EQUIPMENT.
 3. SEE TO ISA STANDARD REFERENCED IN NOTE 1 FOR COMPLETE LISTING OF FUNCTION DESIGNATIONS.
 4. HIGH HIGH AND LOW LOW ALARMS TRIP SHUTDOWNS AND ARE GIVEN SHUTDOWN SYSTEM DESIGNATIONS PER TABLE 18.
 5. EQUIPMENT TAG NUMBERS SEQUENCED BY DIVISIONS OF 10 OR MORE TO

EQUIPMENT TAGGING LEGEND

TABLE 23

CATEGORY	TYPE	DESCRIPTION	TAG NUMBER SERIES
NONE	CAVERNS	CV	CAVERNS
NONE	ROTATING EQUIPMENT	B BLOWERS C COMPRESSORS M MOTOR, ELECTRICAL F FANS G GENERATOR, ELECTRICAL GT GAS TURBINES P PUMPS RE RECIPROCATING ENGINE ST STEAM TURBINES	
	PRESSURE VESSELS	A ACCUMULATOR C COALESCEUR D DRIERS/DEHYDRATORS F FILTERS FC FILTER/COALESCEUR FS FILTER SEPARATOR KO KNOCKOUT PC PACKED COLUMN/TOWER PD PULSATION DAMPENERS RX REACTOR S SEPARATOR SC SCRUBBER SL SLUG CATCHER SP SPHERES ST STORAGE/SURGE TANKS (PRESSURE RETAINING) TC TRAYED COLUMN/TOWER V VESSELS	
	HEAT EXCHANGERS	NONE SPACE HEATER AC AIR COOLED DP DOUBLE PIPE MT MULTI-TUBE PF PLATE & FRAME ST SHELL AND TUBE	
F	FIRED EQUIPMENT	B BOILER BH BATH CA CATALYTIC HEATER CH COIL HEATER EL ELECTRIC HEATER F FURNACE FA FORCED AIR SPACE HEATER H HEATER IN INCINERATOR L FLARE TH THERMOXIDIZER WH WATER HEATER	
T	TANKS (ATMOSPHERIC PRESSURE)		
M	MIXING EQUIPMENT	A AGITATOR J JET MIXER S STATIC IN-LINE MIXER	
SK	SKIDDED/PACKAGED EQUIPMENT	ALL ALL	
NONE	OTHER	FA FLAME ARRESTOR BD BUILDING L LAUNCHER/SCRAPER TRAP MR METER RUNS O ODERIZER PV PROVERS R RECEIVER/SCRAPER TRAP S SILENCER STR STRAINER SV STRAIGHTENING VANE XPMR TRANSFORMER	

EQUIPMENT TAGGING EXAMPLE

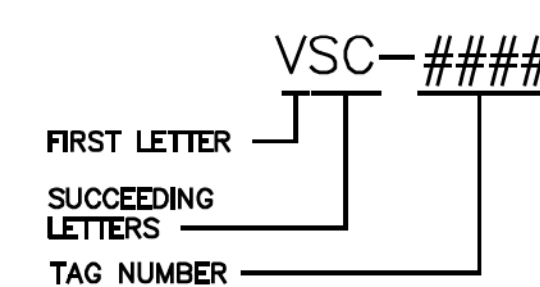

EQUIPMENT SYMBOLS

TABLE 24

NOTE 2

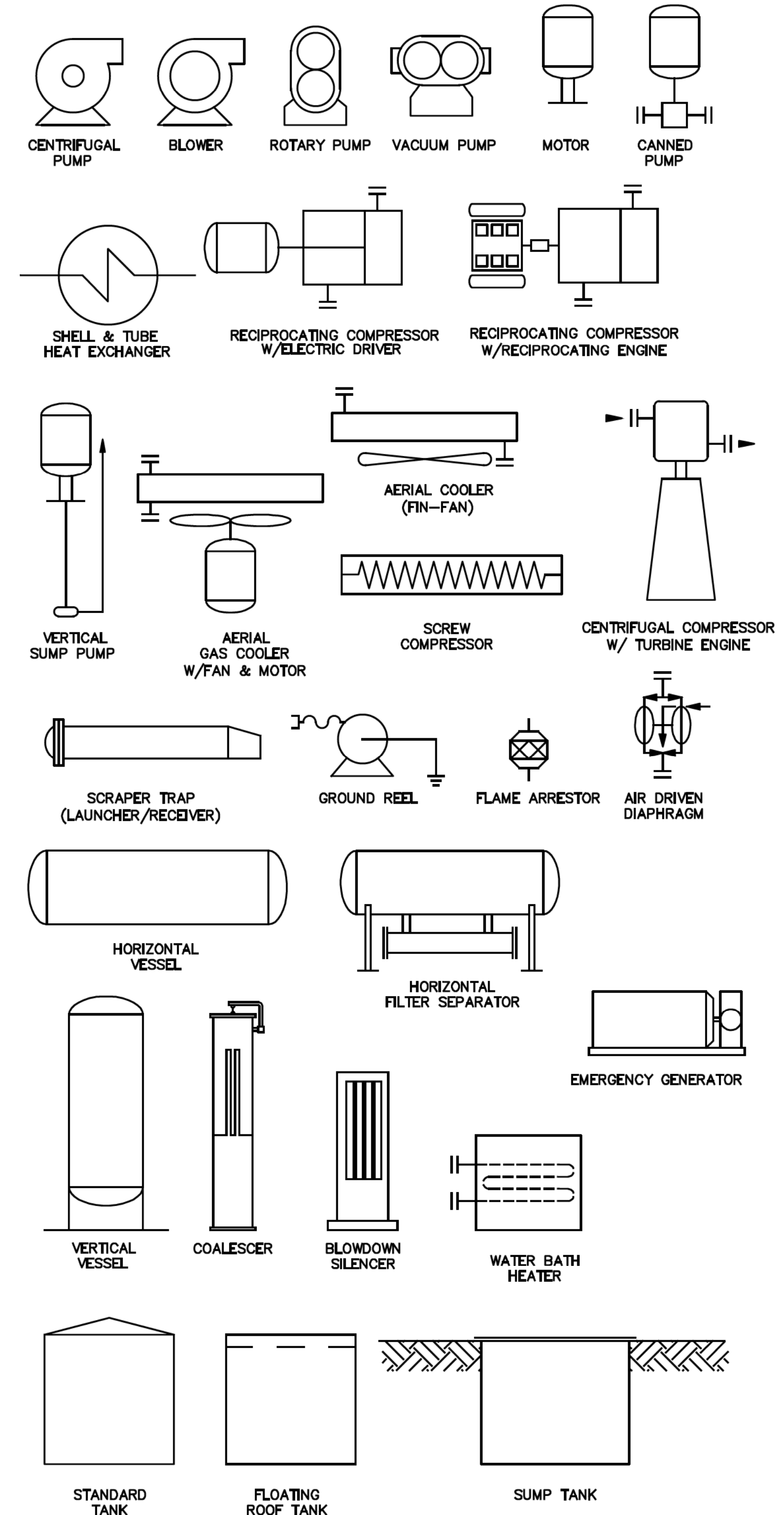

P&ID SYMBOLS AND LEGENDS

6" PROPOSED PIPELINE
 CAMDEN COUNTY CONTROLLER
 KENT COUNTY, DE

ESNG PROJECT CODE: ES XXXX	DATE: 6/19/2026
MRA PROJECT NO: 23098	SCALE: N/A
DESIGN/CHECK BY: JTH/CWB	SHEET: 17 OF 18

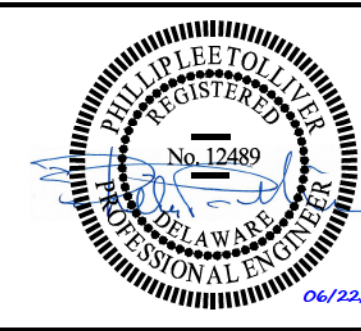

REVISIONS			
NO.	DATE	DESCRIPTION	BY

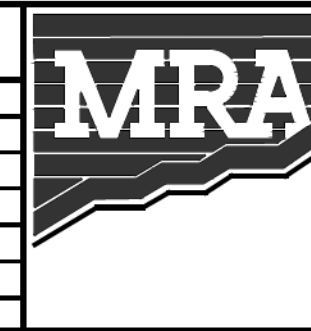

MORRIS & RITCHIE ASSOCIATES, INC.
 ENGINEERS, PLANNERS, SURVEYORS AND
 LANDSCAPE ARCHITECTS
 111 RUTHAR DRIVE
 NEWARK, DE 19711
 (302) 326-2200
 MRA@TA.COM
 © 2025 MORRIS & RITCHIE ASSOCIATES, INC.

EASTERN SHORE
 NATURAL GAS
 500 ENERGY LANE, SUITE 200 DOVER, DE 19901
 TELEPHONE (302) 734-6710 • FAX (302) 734-6745

OWNERSHIP

ANGLES

PLAN VIEW 1" = 30'

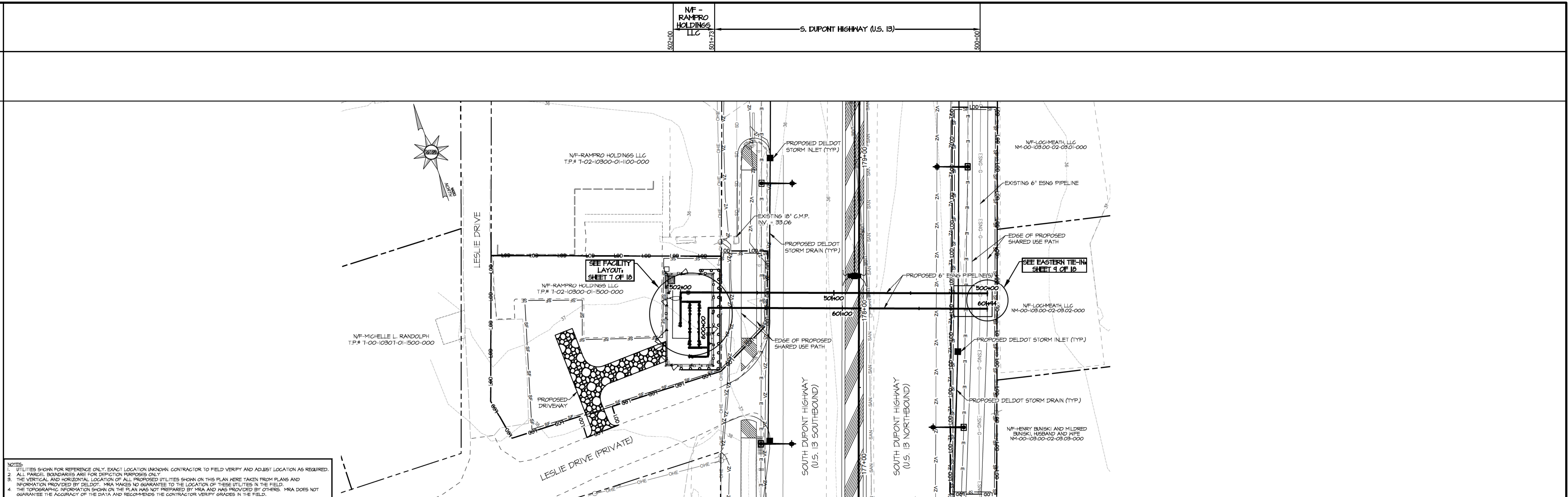

NOTES:
 1. UTILITIES SHOWN FOR REFERENCE ONLY. EXACT LOCATION UNKNOWN. CONTRACTOR TO FIELD VERIFY AND ADJUST LOCATION AS REQUIRED.
 2. ALL PARCEL BOUNDARIES ARE FOR DEPICTION PURPOSES ONLY.
 3. THE VERTICAL AND HORIZONTAL LOCATION OF ALL PROPOSED UTILITIES SHOWN ON THIS PLAN WERE TAKEN FROM PLANS AND INFORMATION PROVIDED BY DELDOT. MRA MAKES NO GUARANTEE TO THE LOCATION OF THESE UTILITIES IN THE FIELD.
 4. THE TOPOGRAPHIC INFORMATION SHOWN ON THE PLAN WAS NOT PREPARED BY MRA AND WAS PROVIDED BY OTHERS. MRA DOES NOT GUARANTEE THE ACCURACY OF THE DATA AND RECOMMENDS THE CONTRACTOR VERIFY GRADES IN THE FIELD.

STATIONS

MATERIAL

TERRAIN

CONSTRUCTION METHOD

ALL STATIONS REFER TO THE PROPOSED NORTHERN 6" INLET PIPELINE

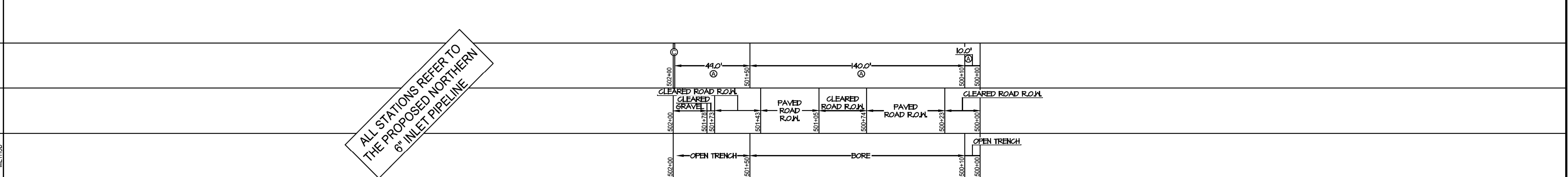

PROFILE 1" = 30'

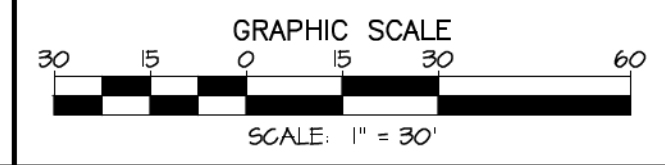
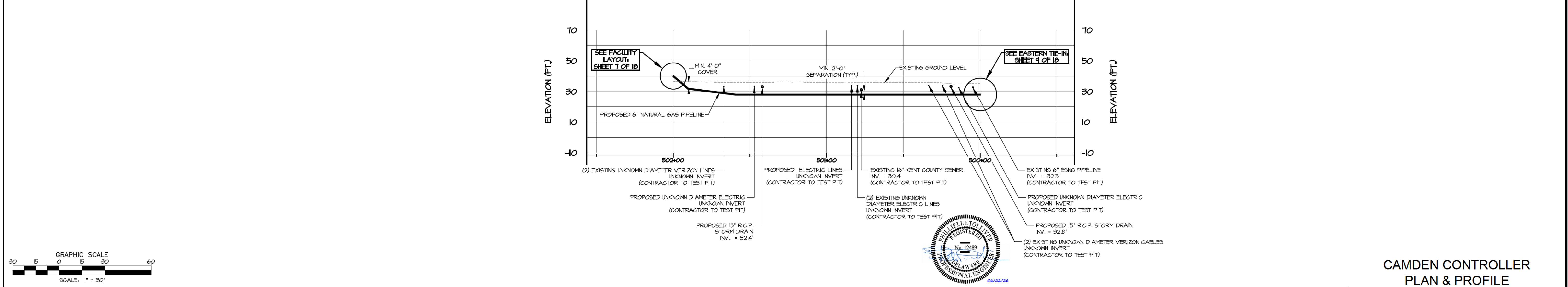

MATERIAL SPECIFICATIONS			
ITEM	DESCRIPTION	QTY	ITEM
A	PIPE, 6" x 0.280" X-52 W/ 14-16 MILS FBE & 40 MILS POWERCONCRETE	392'	
B	ELBOW, 6" x 0.280" Y-52 3R, 90° BEND	1	

TEST LEAD/STATIONS			
STATION	TYPE	STATION	TYPE

REFERENCE DRAWINGS			REVISIONS	
DESCRIPTION	DRAWING NUMBER	NO.	DATE	DESCRIPTION

MRA
 MORRIS & RITCHIE ASSOCIATES, INC.
 ENGINEERS, PLANNERS, SURVEYORS AND LANDSCAPE ARCHITECTS
 111 RUTHAR DRIVE
 NEWARK, DE 19711
 (302) 326-2200
 MRA@GTA.COM
 © 2024 MORRIS & RITCHIE ASSOCIATES, INC.

EASTERN SHORE
 NATURAL GAS
 500 ENERGY LANE, SUITE 200 DOVER, DE 19901
 TELEPHONE (302) 734-6710 - FAX (302) 734-6745

CAMDEN CONTROLLER PLAN & PROFILE
6" PROPOSED PIPELINE
CAMDEN CONTROLLER
KENT COUNTY, DE

ESNG PROJECT CODE: ES XXXX DATE: 6/19/2026
 MRA PROJECT NO: 23098 SCALE: 1" = 30'
 DESIGN/CHECK BY: JTH/CWB SHEET: 18 OF 18