

WETLANDS AND SUBAQUEOUS LANDS SECTION PERMIT APPLICATION FORM

**For Subaqueous Lands, Wetlands, Marina and
401 Water Quality Certification Projects**

**State of Delaware
Department of Natural Resources and Environmental Control
Division of Water**

Wetlands and Subaqueous Lands Section



**APPLICATION FOR APPROVAL OF
SUBAQUEOUS LANDS, WETLANDS, MARINA
AND WATER QUALITY CERTIFICATION PROJECTS**

PLEASE READ THE FOLLOWING INSTRUCTIONS CAREFULLY**Application Instructions:**

1. Complete each section of this basic application and appropriate appendices as thoroughly and accurately as possible. Incomplete or inaccurate applications will be returned.
2. All applications must be accompanied by a scaled plan view and cross-section view plans that show the location and design details for the proposed project. Full construction plans must be submitted for major projects.
3. All applications must have an original signature page and proof of ownership or permitted land use agreement.
4. Submit an original and two (2) additional copies of the application (total of 3) with the appropriate application fee and public notice fee* (prepared in separate checks) to:

**Department of Natural Resources and Environmental Control
Wetlands and Subaqueous Lands Section
89 Kings Highway
Dover, Delaware 19901**

*Application and public notice fees are non-refundable regardless of the Permit decision or application status.

5. No construction may begin at the project site before written approval has been received from this office.

Helpful Information:

1. Tax Parcel Information:

New Castle County	(302) 395-5400
Kent County	(302) 736-2010
Sussex County	(302) 855-7878
2. Recorder of Deeds:

New Castle County	(302) 571-7550
Kent County	(302) 744-2314
Sussex County	(302) 855-7785
3. A separate application and/or approval may be required through the Army Corps of Engineers. Applicants are strongly encouraged to contact the Corps for a determination of their permitting requirements. For more information, contact the Philadelphia District Regulator of the Day at (215) 656-6728 or visit their website at: <http://www.nap.usace.army.mil/Missions/Regulatory.aspx>.
4. For questions about this application or the Wetlands and Subaqueous Lands Section, contact us at (302) 739-9943 or visit our website at: <http://www.dnrec.delaware.gov/wr/Services/Pages/WetlandsAndSubaqueousLands.aspx>. Office hours are Monday through Friday 8:00 AM to 4:30 PM, except on State Holidays.

APPLICANT'S REVIEW BEFORE MAILING

DID YOU COMPLETE THE FOLLOWING?

<u> X </u>	Yes	BASIC APPLICATION
<u> X </u>	Yes	SIGNATURE PAGE (Page 3)
<u> X </u>	Yes	APPLICABLE APPENDICES
<u> X </u>	Yes	SCALED PLAN VIEW
<u> X </u>	Yes	SCALED CROSS-SECTION OR ELEVATION VIEW PLANS
<u> X </u>	Yes	VICINITY MAP
<u> X </u>	Yes	COPY OF THE PROPERTY DEED & SURVEY
<u> N/A </u>	Yes	THREE (3) COMPLETE COPIES OF THE APPLICATION PACKET
<u> X </u>	Yes	APPROPRIATE APPLICATION FEE & PUBLIC NOTICE FEE (Separate checks made payable to the State of Delaware)

Submit 3 complete copies of the application packet to:

**Department of Natural Resources and Environmental Control
Wetlands and Subaqueous Lands Section
89 Kings Highway
Dover, Delaware 19901**

Before signing and mailing your application packet, please read the following:

The Department requests that the contractor or party who will perform the construction of your proposed project, if other than the applicant, sign the application signature page along with the applicant in the spaces provided. When the application is signed by the contractor as well as the applicant, the Department will issue the Permit to both parties. For Leases, the contractor will receive a separate construction authorization that will make them subject to all of the terms and conditions of the Lease relating to the construction

Section 1: Applicant Identification

1. Applicant's Name: Pilottown Marina, Inc. Telephone #: _____
 Mailing Address: c/o Joe Stewart Fax #: _____
P.O. Box 101 E-mail: Jstewartde@comcast.net
Lewes, Delaware 19958
2. Consultant's Name: David Small Company Name: Verdantas LLC
 Mailing Address: 1060 S. Governors Avenue Telephone #: 302-674-9280
Suite 101 Fax #: _____
Dover, DE 19904 E-mail: dsmall@verdantas.com
3. Contractor's Name: Dave Nornes Company Name: Ray Nornes Inc.
 Mailing Address: 508-1 Sunlight Lane Telephone #: 410-726-1852
Berlin, MD 21811 Fax #: _____
 E-mail: dnornes@aol.com

Section 2: Project Description

4. Check those that apply:
 New Project/addition to existing project? Repair/Replace existing structure? (If checked, must answer #16)
5. Project Purpose (attach additional sheets as necessary):
Pilottown Maria requires maintenance dredging of their marina located off of the Lewes & Rehoboth Canal. Hydraulic maintenance dredging includes the removal of up to 2,988.68 c.y. to -6' MLW, with disposal into geotubes for dewatering and then to an off-site location, Chris Magee disposal site, located at 30541 Gum Road, Frankford, Delaware 19945.
6. Check each Appendix that is enclosed with this application:

<input type="checkbox"/>	A. Boat Docking Facilities	<input type="checkbox"/>	G. Bulkheads	<input type="checkbox"/>	N. Preliminary Marina Checklist
<input type="checkbox"/>	B. Boat Ramps	<input type="checkbox"/>	H. Fill	<input type="checkbox"/>	O. Marinas
<input type="checkbox"/>	C. Road Crossings	<input type="checkbox"/>	I. Rip-Rap Sills and Revetments	<input type="checkbox"/>	P. Stormwater Management
<input type="checkbox"/>	D. Channel Modifications/Dams	<input type="checkbox"/>	J. Vegetative Stabilization	<input type="checkbox"/>	Q. Ponds and Impoundments
<input type="checkbox"/>	E. Utility Crossings	<input type="checkbox"/>	K. Jetties, Groins, Breakwaters	<input checked="" type="checkbox"/>	R. Maintenance Dredging
<input type="checkbox"/>	F. Intake or Outfall Structures	<input type="checkbox"/>	M. Activities in State Wetlands	<input type="checkbox"/>	S. New Dredging

Section 3: Project Location

7. Project Site Address: _____ County: N.C. Kent Sussex
Pilottown Road at Marina Drive Site owner name (if different from applicant): _____
Lewes, DE 19958 Address of site owner: _____
8. Driving Directions: From DE-1 S, turn left onto Nassau Rd, turn left onto New Road, at the traffic circle, take the 1st exit and stay on New Road, turn right onto Pilottown Road, destination is on the left
 (Attach a vicinity map identifying road names and the project location)
9. Tax Parcel ID Number: 3-35-4.19-98.00 Subdivision Name: _____

WSLS Use Only:	Permit #s: _____
Type	SP <input type="checkbox"/> SL <input type="checkbox"/> SU <input type="checkbox"/> WE <input type="checkbox"/> WQ <input type="checkbox"/> LA <input type="checkbox"/> SA <input type="checkbox"/> MP <input type="checkbox"/> WA <input type="checkbox"/>
Corps Permit: SPGP 18 <input type="checkbox"/> 20 <input type="checkbox"/> Nationwide Permit #:	Individual Permit # _____
Received Date: _____	Project Scientist: _____
Fee Received? Yes <input type="checkbox"/> No <input type="checkbox"/> Amt: \$ _____	Receipt #: _____
Public Notice #:	Public Notice Dates: ON _____ OFF _____

Section 3: Project Location (Continued)

10. Name of waterbody at Project Location: Lewes & Rehoboth Canal waterbody is a tributary to: Delaware Bay
11. Is the waterbody: Tidal Non-tidal Waterbody width at mean low or ordinary high water Approx. 250 ft
12. Is the project: On public subaqueous lands? On private subaqueous lands?*
- In State-regulated wetlands? In Federally-regulated wetlands?

*If the project is on private subaqueous lands, provide the name of the subaqueous lands owner:

Pilottown Marina Inc.

(Written permission from the private subaqueous lands owner must be included with this application)

13. Present Zoning: Agricultural Residential Commercial Industrial Other

Section 4: Miscellaneous

14. A. List the names and complete mailing addresses of the immediately adjoining property owners on all sides of the project (attach additional sheets as necessary):

#3-35-4.18-83.00 - G. Lawrence Adams, P.O. Box 88, Lewes, DE 19958

#3-35-4.19-102.00 - Lambert's Cove, 409 Pilottown Road, Lewes, DE 19958

- B. For wetlands and marina projects, list the names and complete mailing addresses of property owners within a 1,000 foot radius of the project (attach additional sheets as necessary):

Not Applicable.

15. Provide the names of DNREC and/or Army Corps of Engineers representatives whom you have discussed the project with:

Jason Baumgartner (DNREC)

A. Have you had a State Jurisdictional Determination performed on the property? Yes No

B. Has the project been reviewed in a monthly Joint Permit Processing Meeting? Yes No

*If yes, what was the date of the meeting? _____

16. Are there existing structures or fill at the project site in subaqueous lands? Yes No

*If yes, provide the permit and/or lease number(s):

SL-410/01

*If no, were structures and/or fill in place prior to 1969? Yes No

17. Have you applied for or obtained a Federal permit from the Army Corps of Engineers?

No Pending Issued Denied Date: January 25, 2017

Type of Permit: Maintenance Dredging Federal Permit or ID #: CENAP-OP-R-2016-1049-23

A modification to the issued federal permit is being requested due to the change in disposal method.

18. Have you applied for permits from other Sections within DNREC?

No Pending Issued Denied Date: _____ Permit or ID #: _____

Type of permit (circle all that apply): Septic Well NPDES Storm Water

Other: _____

Section 5: Signature Page

19. Agent Authorization:

If you choose to complete this section, all future correspondence to the Department may be signed by the duly authorized agent. In addition, the agent will become the primary point of contact for all correspondence from the Department.

I do not wish to authorize an agent to act on my behalf

I wish to authorize an agent as indicated below:

I, Joe Stewart, hereby designate and authorize David Small
 (Name of Applicant) (Name of Agent)

to act on my behalf in the processing of this application and to furnish any additional information requested by the Department.

Authorized Agent's Name: David Small
 Mailing Address: 1060 South Governors Avenue
Suite 101
Dover, DE 19939

Telephone #: 302-239-6634
 Fax #: _____
 E-mail: dsmall@verdantas.com

20. Agent's Signature:

I hereby certify that the information on this form and on the attached plans are true and accurate to the best of my knowledge. I further understand that the Department may request information in addition to that set forth herein if deemed necessary to appropriately consider this application.

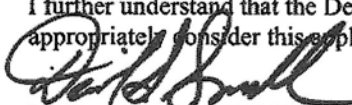
 Agent's Signature

7/21/2025
 Date

21. Applicant's Signature:

I hereby certify that the information on this form and on the attached plans are true and accurate to the best of my knowledge and that I am required to inform the Department of any changes or updates to the information provided in this application. I further understand that the Department may request information in addition to that set forth herein if deemed necessary to appropriately consider this application. I grant permission to authorized Department representatives to enter upon the premises for inspection purposes during working hours.

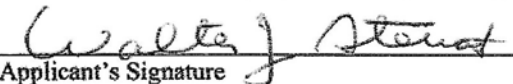
 Applicant's Signature
Joe Stewart - WALTER J. STEWART
 Print Name

1 May 2025
 Date

22. Contractor's Signature:

I hereby certify that the information on this form and on the attached plans are true and accurate to the best of my knowledge, and that I am required to inform the Department of any changes or updates to the information provided in this application. I further understand that the Department may request information in addition to that set forth herein if deemed necessary to appropriately consider this application.

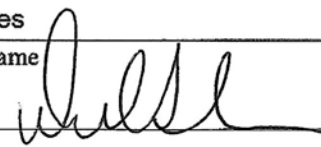
Dave Nornes
 Contractor's Name

 Print Name

12/15/2025
 Date

Authorization Agreement

This Authorization Agreement ("Agreement") is made and entered into as of the date signed below by and between:

Chris Magee ("Owner")
30541 Gum Road
Frankford, Delaware 19945

and

Pilottown Marina Inc. ("Pilottown")
P.O. Box 101
Lewes, Delaware 19958

Purpose

The purpose of this Agreement is to provide written authorization from the Owner for Pilottown to utilize the Owner's facility located at 30541 Gum Road, Frankford, Delaware 19945 ("Facility") for the disposal of dredge material resulting from dredging operations associated with the Pilottown Marina.

Authorization

Chris Magee hereby authorizes Pilottown Marina Inc. to utilize the Facility for the disposal and storage of dredge material as necessary and appropriate, in accordance with all applicable laws, regulations, and permitting requirements.

Terms and Conditions

- The Association agrees to comply with all federal, state, and local regulations governing the disposal of dredge material.
- The Association will ensure that all dredge material disposed of at the Facility is managed responsibly and does not cause harm to the property or environment.
- This authorization is effective upon signature and will remain in effect until revoked in writing by the Owner or upon completion of the dredge material disposal project.
- Any damages to the Facility resulting from disposal activities shall be repaired or compensated by the Association.
- Both parties agree to cooperate in good faith to ensure the safe and lawful execution of this Agreement.

Acceptance and Signature

By signing below, the Owner acknowledges and authorizes Pilottown Marina Inc. to utilize the Facility at 30541 Gum Road, Frankford, Delaware 19945 for the disposal of dredge material.

Owner (Chris Magee):

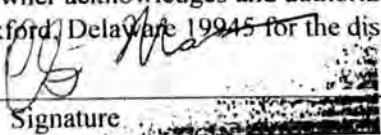
Signature

Date: 12/11/25

Pilottown Marina Inc. Representative:

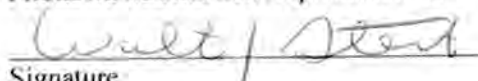
Signature

WALTER J. STEWART
Print

Date: 12/11/25

Scaled Plan View &
Scaled Cross Section



LEGEND

- PILOTTOWN MARINA DREDGE AREA
- - - - - SEDIMENT PROFILE
- DREDGE PROFILE
- / / / / / PROPOSED DREDGING
17,100.31 S.F. AREA TO BE DREDGED TO EL. -6.00
2,988.68 C.Y. TO BE REMOVED
PERMIT LIMITS VOLUME TO 4,320 C.Y.
- - - - - PROPERTY BOUNDARY
- 335-4.19-98.00 PARCEL IDENTIFICATION NUMBER (PIN)

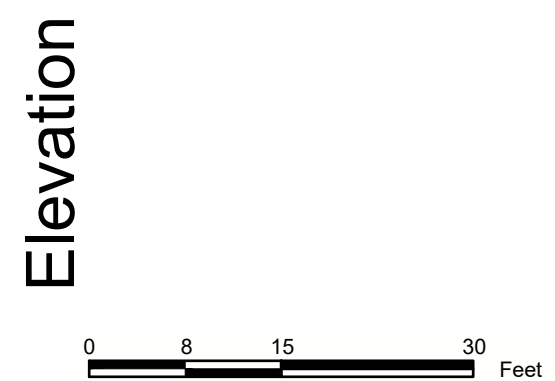
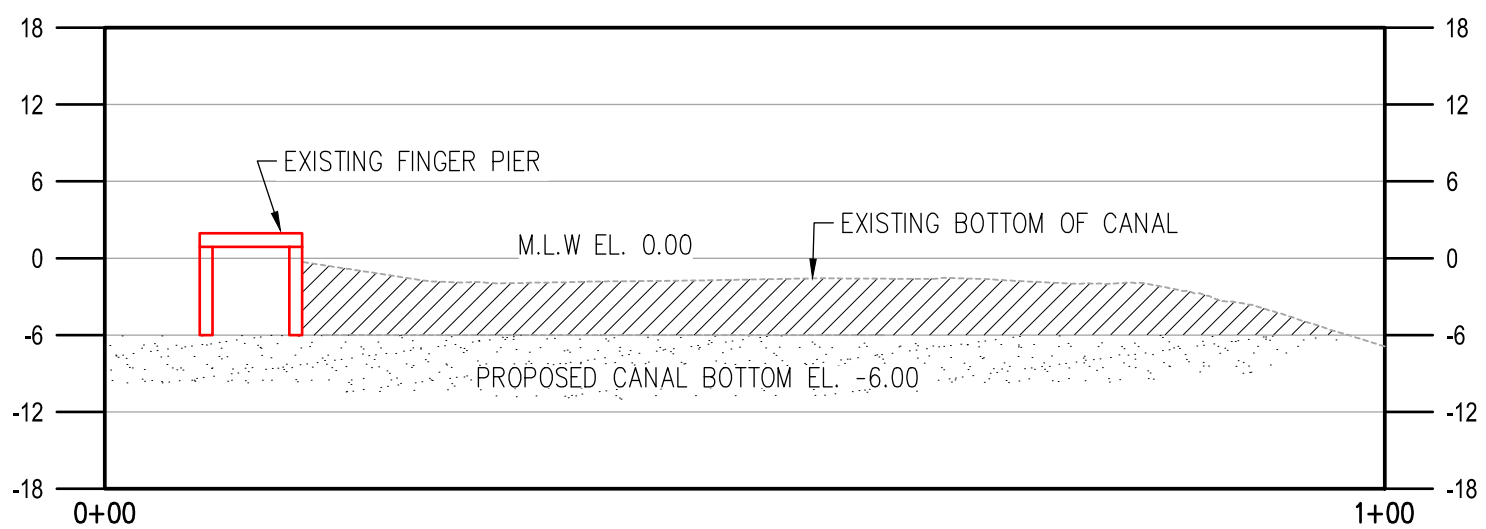

DISCLAIMER: Verdantas LLC has furnished this map to the Client for its sole and exclusive use as a preliminary planning and screening tool. This map is reproduced from geospatial information compiled from third-party sources which may change over time and are not accurate as to mapping, surveying or engineering standards. Verdantas LLC makes no representation or warranty as to the content, accuracy, timeliness or completeness of any information. In no event will Verdantas LLC, its owners, officers, employees or agents, be liable for damages of any kind arising out of the use of this map by Client or any other party.



Harborside Development III, LLC

**Maintenance Dredging Plan
DNREC Permit Application**

409 Pilottown Road
Lewes, Delaware

Project Number	25883
Date	12/12/2025
Author	MN
Scale	AS NOTED
Figure	1

z:\project_files\ga-hz\harborside\25883 - pilottown marina permitting\cad\steeles and plans\25883-site plan-pliko b4-pilottown marina.mxd-2025-12-12.dwg 12/12/2025 10:05 AM

Parcel Map



Pilottown Marina
335-4.19-98.00

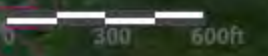

Layers Search Basemaps Select Area Eagleview Print

Show Search Results/Eagleview

Chris Magee Site
553-5.00-31.00

X: -8364225.160032 Y: 4648497.869024

Vicinity Map

Vicinity Map

Pilottown Marina & Chris Magee CDF

Legend

- Chris Magee CDF
- Pilottown Marina

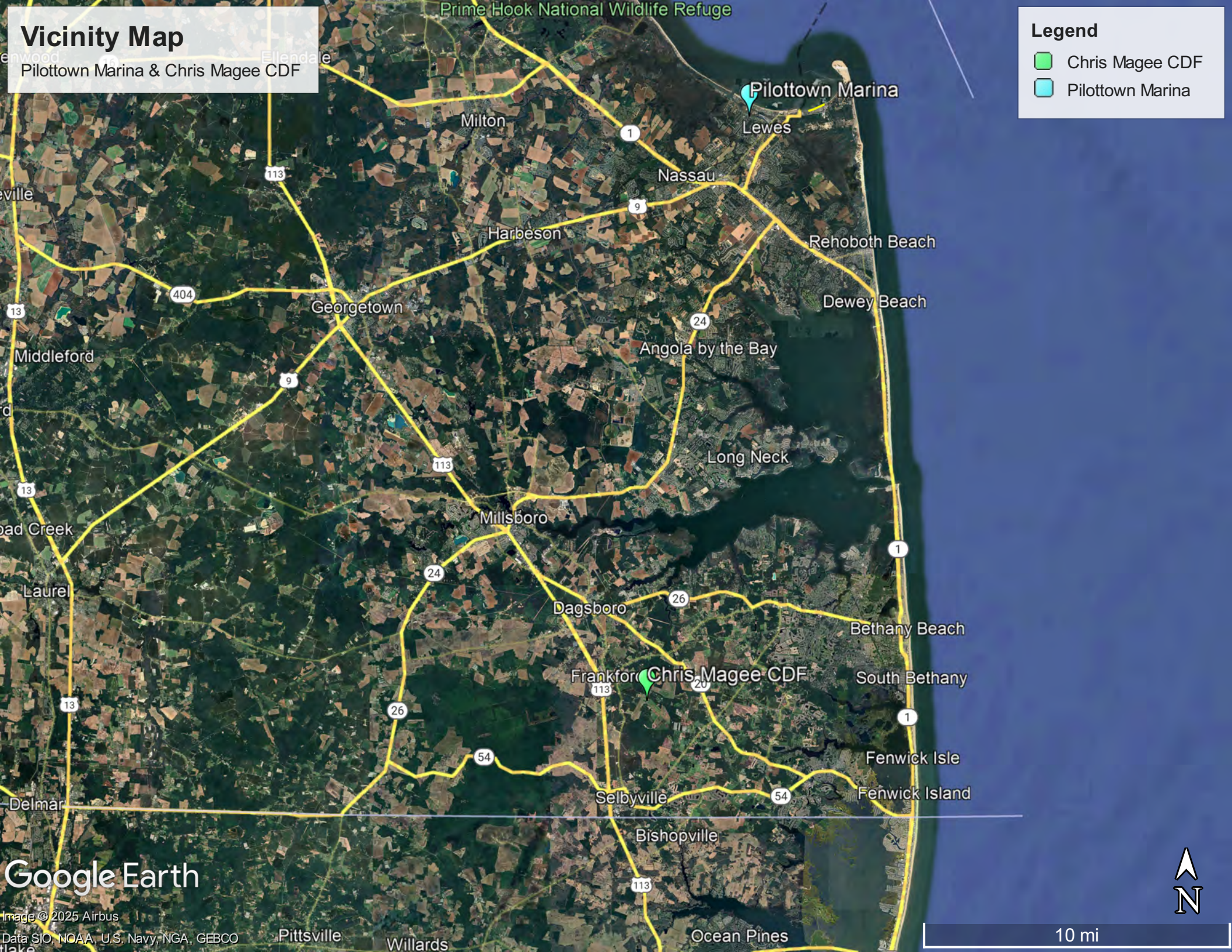

Google Earth

Image © 2025 Airbus
Data SIO, NOAA, U.S. Navy, NGA, GEBCO

Pittsville

Willards

Ocean Pines

10 mi

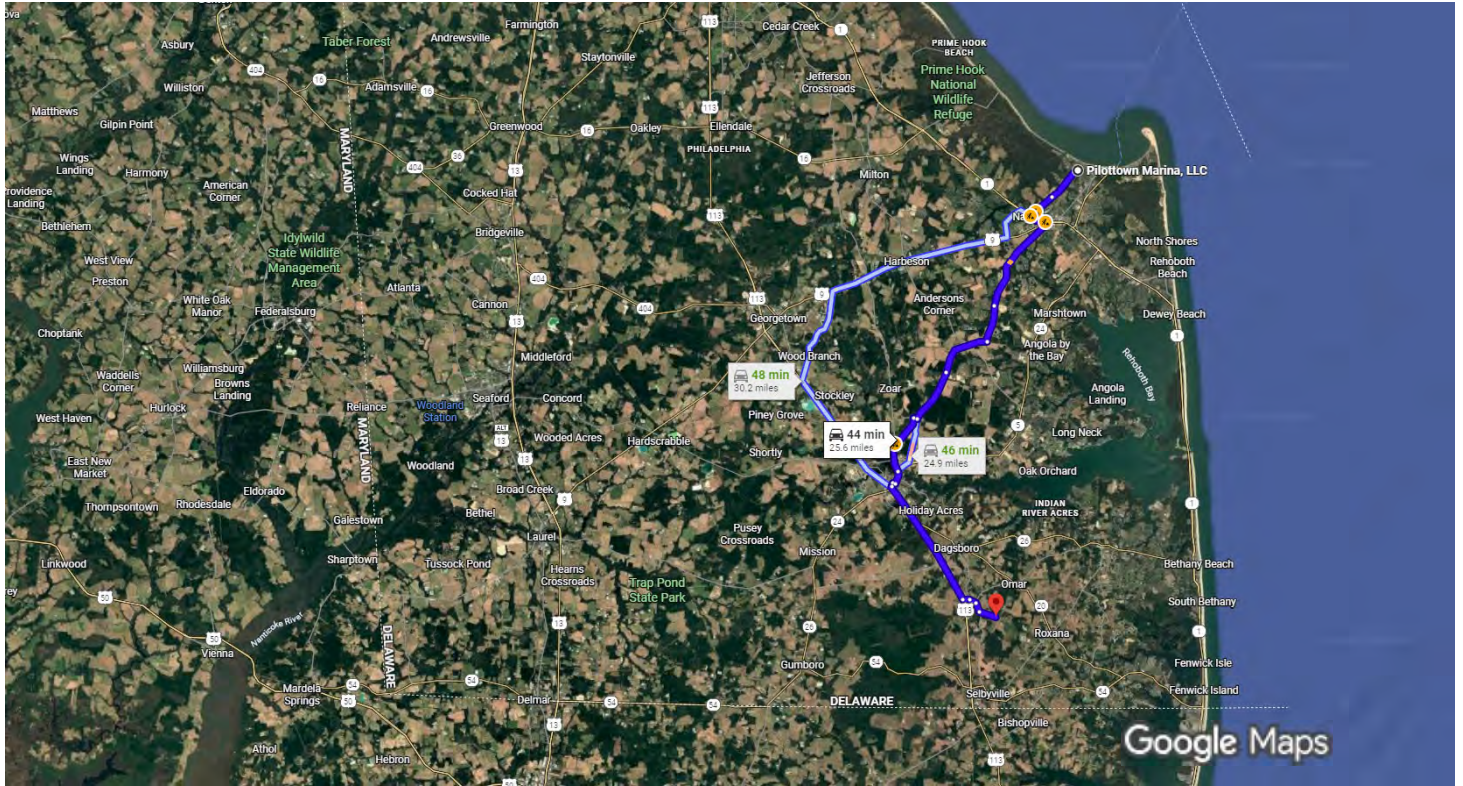

Imagery ©2025 , Map data ©2025 Google 2 mi

Pilottown Marina, LLC
Lewes, DE 19958

Take New Rd to DE-1S

- _____ 7 min (3.1 mi)
- ↑ 1. Head northwest on Pilottown Rd toward New Rd
_____ 463 ft
- ↶ 2. Turn left onto New Rd
_____ 1.6 mi
- 🔄 3. At the traffic circle, take the 2nd exit and stay on New Rd
_____ 1.2 mi
- ↶ 4. Turn left onto Nassau Rd
_____ 0.2 mi

Continue on DE-1 S to Belltown Rd

- _____ 2 min (0.7 mi)
- ↑ 5. Continue straight onto DE-1 S
_____ 0.6 mi
- ↷ 6. Sharp right onto US-9 W
_____ 0.1 mi

Follow DE-23/Beaver Dam Rd/Beaver Dm Rd, Rd 48 and Hollyville Rd to Rd 297/Mt Joy Rd

- 17 min (10.6 mi)
- 7. Use the left 2 lanes to turn left onto Belltown Rd
390 ft
 - 8. At the traffic circle, take the 1st exit onto DE-23/Beaver Dam Rd/Beaver Dm Rd
4.2 mi
 - 9. Turn right onto DE-23 S/Beaver Dam Rd/Beaver Dm Rd
1.6 mi
 - 10. Turn right onto Rd 48/Hollymount Rd
i Continue to follow Rd 48
2.5 mi
 - 11. Continue onto Hollyville Rd
2.3 mi
 - 12. Turn right onto Rd 297/Mt Joy Rd
24 sec (0.2 mi)

Follow Doc Frame Rd to DE-30

- 2 min (1.4 mi)
- 13. Turn left onto Doc Frame Rd
1.4 mi
 - 14. Turn right toward DE-30
82 ft

Continue on DE-30. Take US-113 S/W Dupont Blvd to Gum Rd

- 17 min (8.8 mi)
- 15. Turn left onto DE-30
1.3 mi
 - 16. Merge onto DE-24BUS
0.5 mi
 - 17. Turn right onto W Monroe St
0.1 mi
 - 18. Turn left onto Houston St/Rte 82A
0.2 mi
 - 19. Turn left onto US-113 S/W Dupont Blvd
i Pass by AutoZone Auto Parts (on the right in 0.8 mi)
5.7 mi
 - 20. Turn left onto Daisey St
0.3 mi
 - 21. Turn right onto Clayton Ave/Rte 401

↑ 22. Continue onto Main St 171 ft

↑ 23. Continue onto Rd 376/Pepper Rd 0.3 mi

↑ 23. Continue onto Rd 376/Pepper Rd 0.4 mi

↶ 24. Turn left onto Gum Rd 1 min (0.7 mi)

30451 Gum Rd

Frankford, DE 19945

Property Deed & Survey

3-35-4.19-98.00

PREPARED BY AND RETURN TO:

Sergovic Carmean Weidman,

McCartney Owens, P.A.

406 S. Bedford Street, Suite 1

P.O. Box 751

Georgetown, DE 19947-0751

2016, **THIS CONFIRMATORY DEED**, is made this 22nd day of August

- BETWEEN -

PILOTTOWN MARINA, INC., a Delaware Corporation, c/o Theodore W. Becker of 221 Second Street, P.O. Box 101, Lewes, DE 19947, and formerly known as **F. R. ASSOCIATES, INC.**, a Delaware Corporation, party of the first part,

- AND -

PILOTTOWN MARINA, INC., a Delaware Corporation, c/o Theodore W. Becker of 221 Second Street, P.O. Box 101, Lewes, DE 19958, party of the second part.

WITNESSETH: That the said party of the first part, for and in consideration of the sum of One Dollar (\$1.00), lawful money of the United States of America, the receipt whereof is hereby acknowledged, hereby grants and conveys unto the party of the second part, and their heirs and assigns:

ALL that certain tract, piece or parcel of land, lying and being situate in the City of Lewes, Lewes and Rehoboth Hundred, Sussex County, Delaware, fronting on Pilottown Road and adjoining lands now or formerly of the Commissions of Lewes, adjoining the Lewes and Rehoboth Canal and lands now or formerly of Gladys R. Toms Estate and being more particularly described as follows, to wit:

BEGINNING at a point on the northeasterly side of Pilottown Road, said point being a corner of lands now or formerly of Gladys R. Toms Estate and the lands herein; thence North 56 degrees 44 minutes 20 seconds West for a distance of 396.99 feet to a point, said point being a corner for the lands herein and lands now or formerly of the Commissioners of Lewes; thence along and with the line of the lands herein and lands now or formerly of the Commissioners of Lewes North 39 degrees 12 minutes 30 seconds East for a distance of 210.14 feet to a point on the low water line of the Lewes and Rehoboth Canal; thence along and with the low water line and long the bulkhead the following four (4) courses and distances: (1) South 53 degrees 15 minutes 15 seconds East for a distance of 184.54 feet to a point; thence (2) North 65 degrees 54 minutes 30 seconds East for a distance of 12.12 feet to a point; thence (3) South 27 degrees 51 minutes 20 seconds East for a distance of 46.18 feet to a point; and (4) South 44 degrees 57

80

cm

minutes 45 seconds East for a distance of 183.21 feet to a point, being a corner for the lands herein and for lands now or formerly of Gladys R. Toms Estate; thence along and with the line of the lands herein and lands now or formerly of Gladys R. Toms Estate South 46 degrees 39 minutes 10 seconds West for a distance of 152.44 feet to a point on the said northeasterly side of Pilottown Road, being the point and place of beginning, and said to contain 1.75 acres of land, more or less.

BEING the same lands conveyed unto F. R. Associates, Inc., a Delaware Corporation, by Corrective Deed of Pilottown Marina Associates, a Delaware General Partnership, said Corrective Deed dated August 7, 1989, and filed for record in the Office of the Recorder of Deeds, in and for Sussex County, at Georgetown, Delaware, in Deed Book 1665, Page 118. The above Corrective Deed was to correct the address of the Grantee, said Deed dated August 7, 1989 and recorded in the Office of the Recorder of Deeds, in and for Sussex County, at Georgetown, Delaware, in Deed Book 1658, Page 249.

This Confirmatory Deed corrects the grantee, to Pilottown Marina, Inc., in reference to a Corporation name change for F.R. Associates, Inc. to Pilottown Marina, Inc., with the Office of the Secretary of State, State of Delaware, Division of Corporations, on July 24, 1989, a photocopy of which is attached hereto as Exhibit "1".

THE REMAINDER OF THIS PAGE WAS INTENTIONALLY LEFT BLANK
SIGNATURE PAGE TO FOLLOW

Consideration:	.00

County	.00
State	.00
Town	.00
Total	.00
Received: Maria T Aug 23, 2016	

IN WITNESS WHEREOF the said party of the first part has caused these presents to be signed by its proper officers and its corporate seal to be hereunto affixed the day and year aforesaid.

Pilottown Marina, Inc.

By: Theodore W. Becker
President

Attest Wally Stunt
Secretary

STATE OF DELAWARE :

: ss.

COUNTY OF SUSSEX :

BE IT REMEMBERED, that on this 22nd day of August A.D., 2016, personally came before me, the Subscriber, a Notary Public for the State and County aforesaid, Theodore W. Becker, President of Pilottown Marina, Inc., a Corporation of the State of Delaware, party to this Indenture, known to me personally to be such, and acknowledge this Indenture to be his act and Deed, and the act and the Deed of the said Corporation; that the signature of the President is in his own proper handwriting; that the seal affixed is the common and Corporate Seal of the said Corporation duly affixed by its authority; and that the act of signing, sealing, acknowledging and delivering the said Indenture was first duly authorized by resolution of the Board of Directors of the said Corporation.

GIVEN under my Hand and Seal of Office, the day and year aforesaid.

ELLEN LORRAINE McCABE
NOTARY PUBLIC
STATE OF DELAWARE
My commission expires May 10, 2020

Ellen Lorraine McCabe
NOTARY PUBLIC

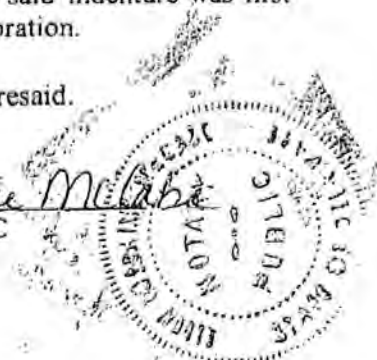

TOWN OF LEWES
REALTY TRANSFER TAX
Serial Number 2395
Amount of City Tax exempt
Date Recorded 8/23/16
By [Signature]

DAVID J. SIMMONS & ASSOCIATES, LLC

DAVID J. SIMMONS, J.D., M.TAX., L.L.M., (ESTATE PLANNING)

BOARD CERTIFIED WILLS, TRUSTS & ESTATES (FLORIDA BAR)

BOARD CERTIFIED SPECIALIST IN ESTATE PLANNING, TRUST AND PROBATE LAW (OHIO BAR)

FELLOW AMERICAN COLLEGE OF TRUST AND ESTATE COUNSEL

MEMBER OF FLORIDA, OHIO, AND NEW YORK BARS

EMAIL: dsimmons@djsestatelaw.com

July 2, 2025

To Whom It May Concern

This letter confirms that Walter J. Stewart is currently serving as President of Pilottown Marina, Inc. and has full authority to sign any documents regarding Pilottown Marina, Inc. Please see attached Corporate Resolution.

Please contact me at 330-283-2780 if you have any questions.

Sincerely,

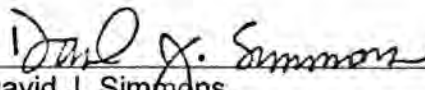

David J. Simmons

cc: Walter J. Stewart

FLORIDA OFFICE
900 Fifth Avenue South, Suite 202
Naples, Florida 34102
Phone: 239-529-5298

OHIO OFFICE
4690 Munson St., N.W., Suite B
Canton, Ohio 44718
Phone: 330-499-8899

Corporate Resolution for the Shareholders
of
Pilottown Marina, Inc.

The undersigned, being the Shareholders of Corporation, effective October 6, 2024, and until revoked by further resolution, authorize, approve, and ratify by unanimous consent, without a meeting, the following resolution:

WHEREAS, Pilottown Marina, Inc. (the "Corporation") is an S Corporation organized under the laws of Delaware; and

WHEREAS, the Board of Directors and all Shareholders approve authorizing the President to sign documents on behalf of the Corporation;

NOW, THEREFORE, BE IT RESOLVED THAT:

1. Walter J. Stewart, President, is authorized to sign and execute all documents, contracts, and agreements, including financial, legal, and operational documents, on behalf of the Corporation, as needed for its business, per the bylaws and applicable law.
2. This includes, but is not limited to, deeds, leases, loans, and bank account agreements.
3. All prior document-signing actions by the President are ratified.
4. Unanimously approved by all Shareholders, as shown by their signatures.

APPROVED BY:

Shareholders:

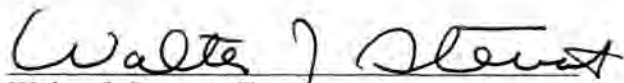

Walter J. Stewart, Trustee
The Theodore W. Becker, Jr. Revocable Trust
dated August 16, 1996

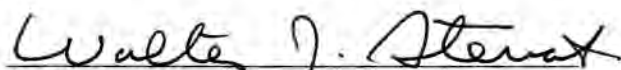

Walter J. Stewart, Trustee
The Walter J. Stewart Revocable Trust
dated August 16, 1996, as amended

PILOTTOWN MARINA

SUSSEX COUNTY, DE

HYDROGRAPHIC SURVEY

AUGUST 5, 2024

(MLW)

MLW Elevation	Mean Elevation	Color
-15.0	-13.0	
-11.0	-9.0	
-8.0	-7.0	
-7.0	-5.0	
-5.0	-3.0	
-3.0	+1.0	
+1.0	5.0	

LEWES AND REHOBOTH CANAL

← EBB

→ FLOOD

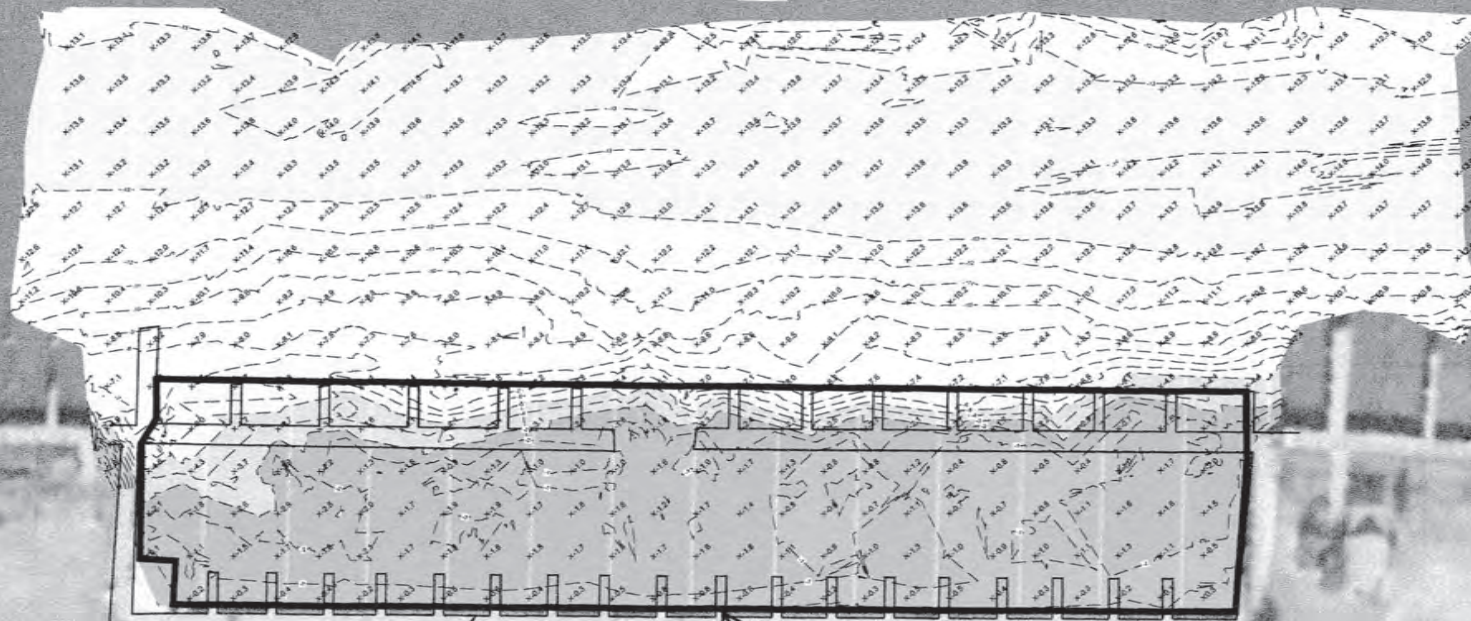

EXISTING PER - APPROXIMATE (TYP)

LIMIT OF CREDGING TO (18' MLW)
CUT VOLUME = 4,400 CY



LEGEND

- - - - - CONTOUR LINE
- x .00 ELEVATION LABEL 200' W

NOTES:

1. SOUNDINGS WERE OBTAINED USING AN UNIMBARA 2-Axis DEPTH SOUNDER @ 20MHZ.
2. SOUND VELOCITY OBTAINED USING AN UNIMBARA HYDROBAR.
3. THE DATA ON THIS MAP REPRESENT THE GENERAL CONDITIONS EXISTING ON AUGUST 5, 2024.
4. ROBERT PLITKO, JR. FAA REMOTE PILOT CERT# 4774514
5. ROBERT PLITKO, JR. DELAWARE LICENSED ENGINEER P# 1430

PILOTTOWN MARINA
PRE-CONSTRUCTION HYDROGRAPHIC SURVEY
VERTICAL DATUM: MLW

SUSSEX COUNTY DELAWARE

PLITKO ENGINEERING
P
HYDROGRAPHIC SURVEY
33 ATLANTIC AVE., STE 3
OCEAN VIEW, DE 19879
Phone (302) 537-1919



PROJECT DATUM
HORIZONTAL: 83' NAD 83
VERTICAL: MLW

RD SURVEY	DATE
DRAWING: DJC	08/05/24
REVIEW: RJP	
SHEET	

V100

Appendix R - Maintenance Dredging or Excavating

MAINTENANCE DREDGING OR EXCAVATING

- If dredged material is to be placed in a disposal site, a separate map showing the location of the disposal site should be attached. This drawing must indicate the proposed retention levees, weirs, spillways, and/or devices for retaining the materials.
- Bottom samples to determine heavy metals or other toxic materials must be taken and analyzed if deemed necessary by the DNREC staff. The responsibility, as well as the expense incurred for obtaining and analyzing these samples, must be borne by the applicant.
- If maintenance dredging is to be done, evidence of previous dredging must be provided. Any previously issued permit with drawings which indicates the date the dredging occurred, the area involved and dredging depth constitutes acceptable proof.
- Please make sure answers to all of the questions in this appendix correspond to information on the application drawings.

1. How many cubic yards of material will be MAINTENANCE DREDGED or excavated channelward of the:

- a. Tidal waters: mean high water line? 2,988 +/- ___ cu. yds.
 mean low water line? 2,988 +/- ___ cu. yds.
- b. Non-tidal waters: ordinary high water line? _____ cu. yds.

Does this account for the total volume of proposed dredging for the project? X Yes _____ No

If there is new dredging associated with this project (dredging beyond previously authorized dimensions) please fill out appendix S for new dredging.

2. What will be the dimensions of the dredged or excavated area relative to mean low water (for tidal areas only) or ordinary water level (for non-tidal areas only)?

400' +/- length -6' depth 50' +/- base width 400' +/- top width

3. What are average existing depths in area of proposed dredging? -3.65 ft. (mlw/ohw)
 Include a survey of proposed and existing depths on application drawings.

See attached 2024 Hydrographic Survey by Plitko

4. What is the proposed dredging depth in relation to surrounding bathymetry? -6.0 ft.(mlw/ohw)
 Indicate both proposed depths and surrounding depths on attached drawings.

5. By what method(s) (hydraulic, clamshell or other) will the dredging be done? If other, explain:

Hydraulic

6. What is proximity of the dredging project to the nearest creek bank or banks? 200 ft.
What are existing land uses along this bank(s)?

Undeveloped land.

Describe the existing shoreline along this bank (vegetation, rip-rap, bulkhead, etc.).

Vegetation

7. Describe characteristics of the material to be disposed including:
- Physical nature of material (i.e. sand, silt, clay, etc.). Give percentages of various fractions if available.

Material consists predominately of sandy mud.

- Chemical composition of material - Many areas have sediments with high concentration of pollutants (chemicals, organics etc.) which may be re-suspended or reintroduced into the water. For heavily industrialized sites, a chemical analysis of this material should be provided (if applicable).

Information not available.

- What are the dewatering properties of material to be disposal of?

Material is expected to dewater within a couple of months

8. How will the dredged or excavated material be transported to its disposal area?

Dredged material from the project site will be hydraulically pumped into geotubes to dewater in the Pilottown Marina parking lot. Following dewatering, the material will be transported via truck to the Chris Magee CDF.

9. Land Disposal Areas.

See attachment.

- Describe dimensions, characteristics and exact locations of the proposed dredged material disposal site (provide photographs, directions to, and complete plans of disposal site).
- Describe method of dredged material containment (embankment, behind bulkhead, etc.)
- What type of leachates will be produced by the spoil material and what is planned for the protection of groundwater?
- Disposal site coordinates _____ latitude _____ longitude
- What methods will be used to ensure that spoil water does not adversely affect water quality both during construction and after completion of the project?
- Describe present land use of the disposal site.

10. Water Disposal Areas/ Beneficial Use Projects

Describe methods to be used for water disposal including volumes and site selection, and containment (if applicable). Include Fill or Wetland Appendix if applicable.

Not applicable.

11. Describe the existing water characteristics at the site, including chemical analysis for water quality.

Information not available.

12. Identify the dredging and disposal schedule to ensure that operations do not degrade water quality during times of anadromous fish migration.

Dredging is expected to take place in 2026, and will comply with all time of year restrictions.

13. Has an Erosion and Sediment Control Plan been approved by the designated plan approval agency for the project? An Erosion and Sediment Control Plan is required for any project disturbing more than 5,000 square feet of uplands. Final approved plans must be received by this office prior to permit issuance.

Yes No Not required

Important time of year restriction information:

Please be advised that all dredging in the Inland Bays must be undertaken between September 1 and December 31 in order to protect summer and winter flounder and other aquatic species. Dredging in other Delaware waters may also be subject to certain time of year restrictions in order to protect fish and wildlife. Contact DNREC for more specific information regarding the restrictions that may apply within your project area.

Appendix R Attachment

Appendix R Attachment

9. Land Disposal Areas

- a. After the dredged material has dewatered in the geotubes, the material will be transported by truck to the Chris Magee CDF located at 30541 Gum Road in Frankford, Delaware 19945. A survey of the CDF is provided as an attachment to this permit application.
- b. During dewatering, the dredged material will be contained in geotubes, which will be further contained by silt fencing and riprap. At the Chris Magee Spoil site, dredged material will be contained by existing earthen berms.
- c. No adverse effects from the leachate are expected. Leachate is anticipated to be of similar quality to the surface water in the Lewes and Rehoboth Canal.
- d. Disposal site coordinates:
 - i. USACE CDF: Latitude: 38.507010° North, Longitude: -75.210613° West
- e. Dredged material will be hydraulically pumped directly into geotubes, so there will be no adverse impacts to water quality in the marina nor the adjacent waterway, Lewes and Rehoboth Canal, during dredging. While the dredged material dewateres in the geotubes, super silt fencing with a section of riprap, approximately 18-inches tall, will be used to control water flow in the Pilottown Marina parking lot. Following dewatering, the dredged material will be transported via truck to the Chris Magee Spoil Site. At the site, dredged material will be contained within an existing confined upland disposal area (existing earthen berms for containment; sluice for outflow).
- f. The geotubes will be placed in the parking lot of the Pilottown Marina, which is currently comprised of crushed shells. The Chris Magee Spoil site is currently used as an existing dredge spoil disposal area.

Disposal Site Aerial

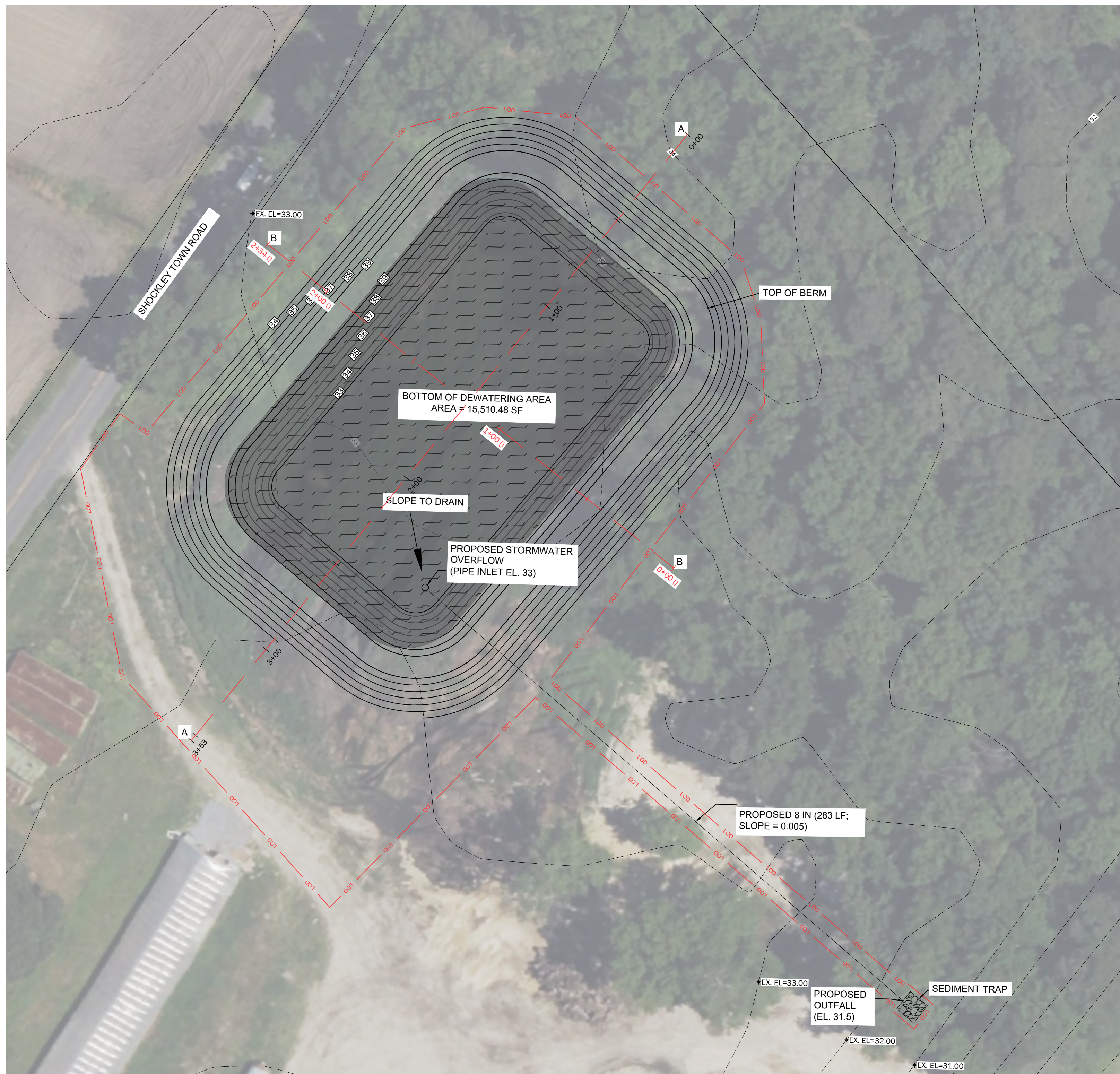

LEGEND

- LIMITS OF DISTURBANCE (1.55 AC)
- ADJACENT PROPERTY LINES
- EXISTING GRADE (BASED ON DELAWARE LIDAR DEM DATED 2014)
- STORMWATER OVERFLOW PIPE (8 IN)
- DREDGE MATERIAL DEWATERING AREA (AREA = 24,653 SF)

NOTES:

- TOTAL DREDGED MATERIAL = 2988 CY (80,676 CF) PER EXISTING PERMIT
- VOLUME OF DEWATERING AREA PROVIDED = 110,938.5 CF
- BOUNDARY SURVEY HAS NOT BEEN CONDUCTED ON THE PROJECT SITE.

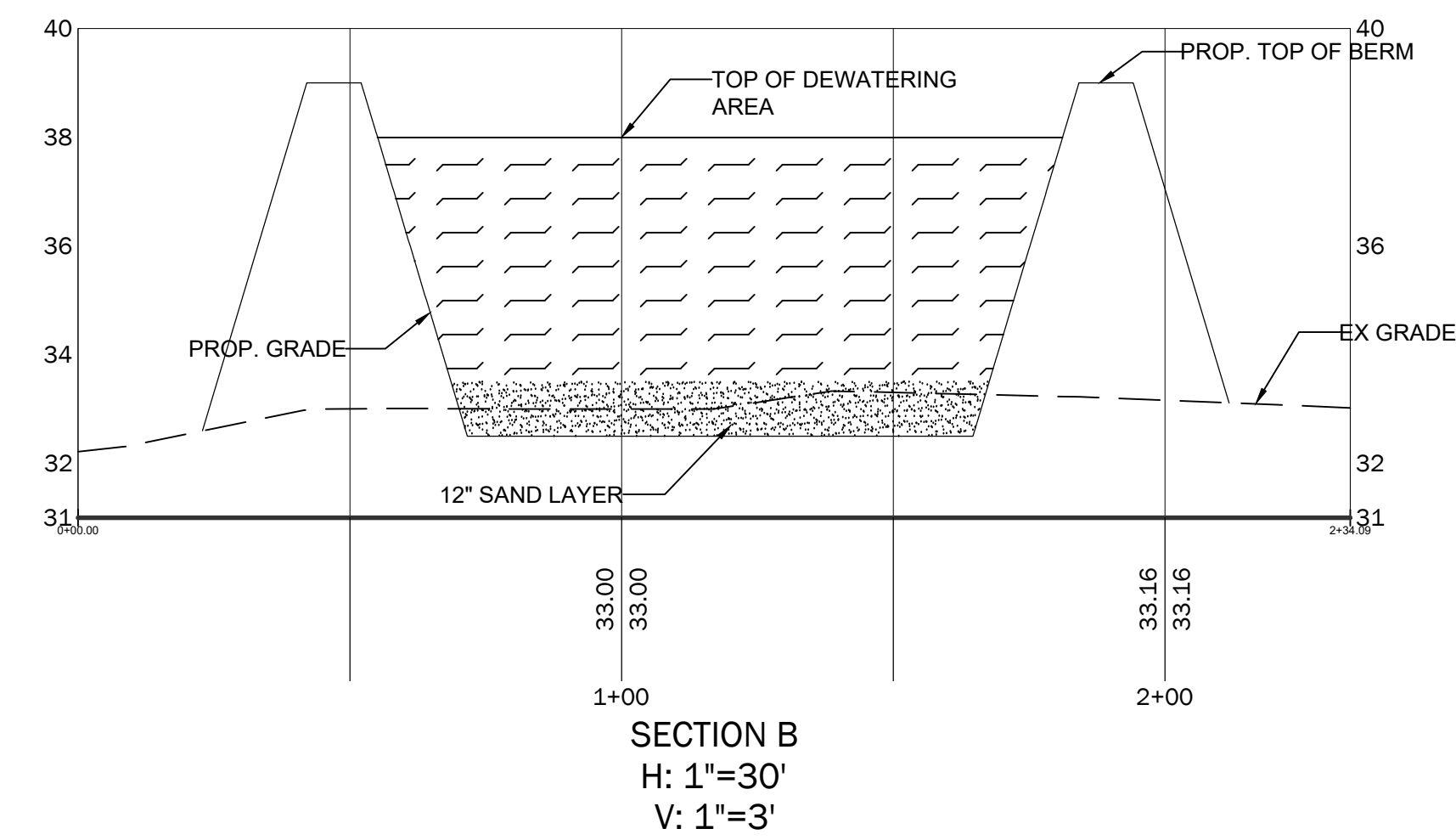
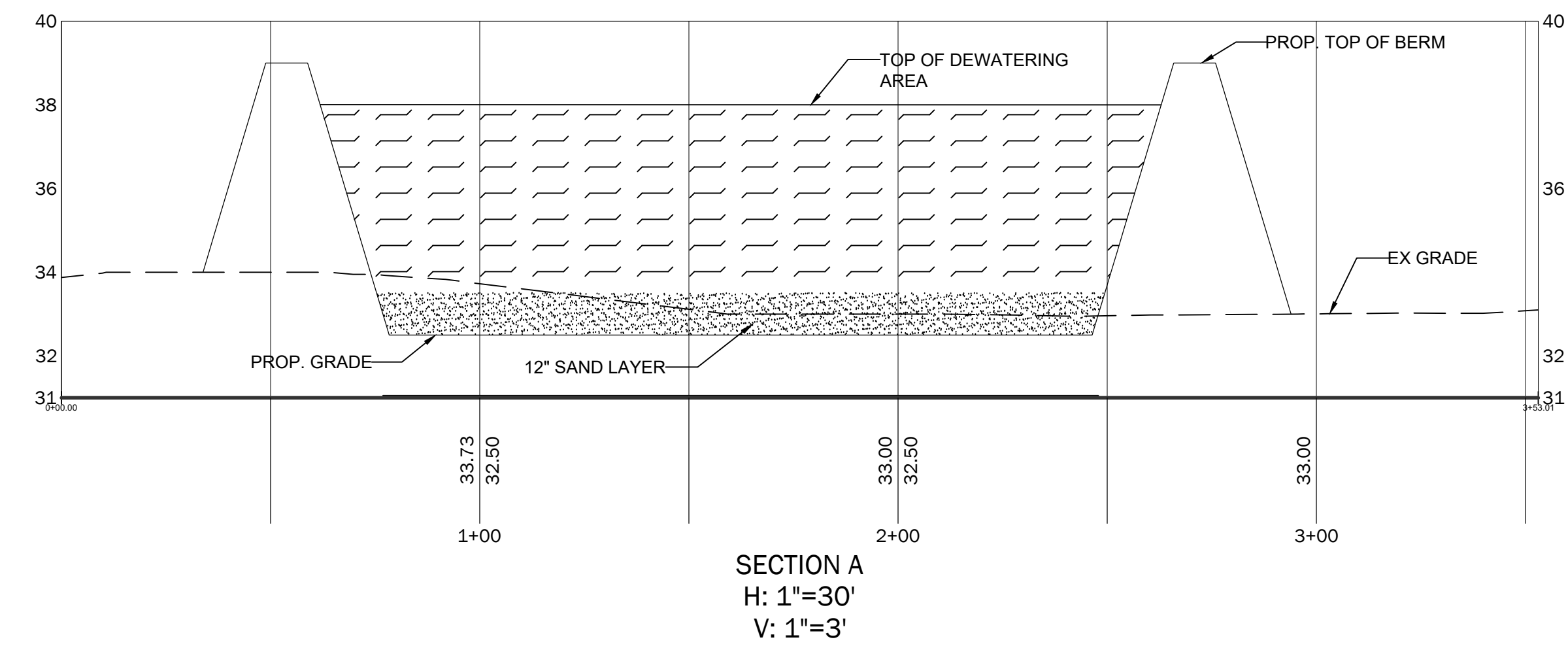

REVISIONS

PLITKO ENGINEERING
 ENGINEER - SURVEY - HYDROGRAPHIC
 53 ATLANTIC AVE., STE 3
 OCEAN VIEW, DE 19970
 Phone (302)-537-1919

**PILOTTOWN MARINA
 DREDGE DISPOSAL AREA**
 TAX MAP: 533-5.00-31.00
 30541 GUM ROAD
 FRANKFORD SUSSEX COUNTY DELAWARE

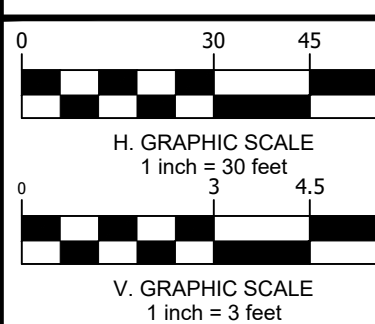





SITE PLAN:	DATE
DRAWING:	8/27/25
REVIEW: RP	

SHEET
C100

Pilottown Marina

(3) 30'x 150' Geo-Tubes.

Legend

-  Discharge Box
-  Line Measure
-  Pilottown Marina
-  Discharge Box



Google Earth

Image © 2025 Airbus

200 ft

Pilottown Marina
2021 DNREC Permit (SP-302/20)



STATE OF DELAWARE
DEPARTMENT OF NATURAL RESOURCES AND
ENVIRONMENTAL CONTROL

DIVISION OF WATER

RICHARDSON & ROBBINS BUILDING
89 KINGS HIGHWAY
DOVER, DELAWARE 19901

WETLANDS &
SUBAQUEOUS LANDS

PHONE
(302) 739-9943

Pilottown Marina, Inc.
c/o: Theodore W. Becker, Jr.
P.O. Box 101
Lewes, DE 19958
Tax Parcel: (Dredging) 3-35-4.19-98.00
Disposal Site Tax Parcel.: 3-35-4.19-67.00

Subaqueous Lands Permit: SP-302/20
Water Quality Certification: WQ-302/20
Wetlands Permit: WE-302/20
Date of Issuance: 2/2/2021
Construction Expiration Date: 2/2/2024
Amended Date: N/A

SUBAQUEOUS LANDS PERMIT

GRANTED TO:

Pilottown Marina, Inc.

FOR THE FOLLOWING ACTIVITIES:

- To hydraulically maintenance dredge to a depth of -6 feet MLW, removing up to 4,035 cubic yards of material.
- To temporarily place a 12-inch diameter pipeline across approximately 120 linear feet of State-regulated tidal wetlands.
- To hydraulically pump up to 4,035 cubic yards of material to an Army Corps of Engineers upland, confined disposal facility, located approximately 1,100 feet east of the dredging location.

LOCATED ON PRIVATE SUBAQUEOUS LANDS AND STATE-REGULATED WETLANDS:

In the Lewes and Rehoboth Canal
At Pilottown Marina
At the intersection of Pilottown Road & Marina Drive
Lewes, Sussex County, Delaware

Pursuant to the provisions of 7 Del. C., §7205, the Department's Regulations Governing the Use of Subaqueous Lands, 7 Del. C., Section 6604, the Department's Wetlands Regulations, 7 Del. C., Section 6003, the Department's Surface Water Quality Standards and Section 401 of the Clean Water Act, permission is hereby granted on this 2nd day of February A.D. 2021, to construct the above-referenced project in accordance with the approved plans (5 sheets), as approved on January 21, 2021; and the application dated August 12, 2020, and received by this Division on August 13, 2020.

WHEREAS, pursuant to the provisions of 7 Del. C., §7203 and 7 Del. C. §6604, the Secretary of the Department of Natural Resources and Environmental Control through his duly authorized representative finds that it is not contrary to the public interest if this project is approved subject to the terms and conditions herein set forth.

WHEREAS, in accordance with Section 401 of the Clean Water Act, 33 U.S.C. Section 1341 and 7 Del. C., Chapter 60, the State of Delaware, by and through the Department of Natural Resources and Environmental Control, certifies that the permitted activity will be conducted in a manner which will not violate the applicable water quality standards of the State of Delaware, subject to the terms and conditions of this approval.

NOW THEREFORE, this Permit/Certification is issued subject to the attached Subaqueous Lands Permit and the Wetlands General Conditions and the following special conditions:

SPECIAL CONDITIONS (Subaqueous Lands & Wetlands Permits)

1. This approval is in accordance with the plans and application submitted to the Department of Natural Resources and Environmental Control, a copy of which is attached hereto and made a part hereof.
2. The authorized activity in subaqueous lands shall be for the explicit purpose of maintaining navigable water depths; the authorized activity in State-regulated tidal wetlands is for the explicit purpose of placing a temporary pipeline to transfer the dredged material to the disposal area. Any other use without prior written approval shall constitute reason for this Permit being revoked.
3. This Permit shall be valid for a three (3) year period and authorizes the hydraulic dredging of up to 3,500 cubic yards of material during one dredging event.
4. The Wetlands and Subaqueous Lands Section shall be notified prior to the commencement of the dredging.
5. In order to protect marsh nesting birds (clapper rail & seaside sparrow) and populations of *Paralichthys dentatus* (summer flounder) & *Morone saxatilis* (striped bass), no work shall take place between March 1 to September 30 of any given year.
6. The sediments will be transported by a hydraulic pipeline. The pipeline shall be placed across State-regulated wetlands in a manner that it does not negatively impact the surrounding environment. Any wetlands disturbed during this dredging event shall be restored to their pre-disturbance conditions.
7. The pipeline shall be kept in good condition at all times and any leaks or breaks shall be promptly and properly repaired.
8. To avoid adverse impacts to fish species, measures shall be taken to minimize sedimentation during the dredging event.
9. Erosion and sediment control measures shall be implemented in accordance with the specifications and criteria in the current Delaware Erosion and Sediment Control Handbook, so as to minimize entry and dispersal of sediment and other contaminants in surface waters.

10. Prior to the commencement of the dredging operation, the disposal area and berms shall be examined to ensure that they are in good condition, and repairs shall be completed if necessary. The WSLs shall be notified of any changes in the location of the disposal area prior to the commencement of dredging operations.
11. All dredging and filling are to be conducted in a manner consistent with sound conservation and water pollution control practices. Spoils and fill areas are to be contained in a manner that prevents the entrance of the dredged material into any surface water or wetland.
12. The pipeline shall be placed in the Lewes and Rehoboth Canal in accordance with the approved plans and in a manner such that it does not impede navigation or cause hazardous conditions. The WSLs shall be notified of any significant change to the alignment of the pipeline shown on the approved plans prior to the change of said alignment.
13. The post-dredging water depth shall not exceed 6.0 feet below the MLW line. A post-dredging bathymetric survey of the site, showing depths relative to mean low water shall be submitted to this office within 60 days of the completion of the dredging.
14. The permittee shall notify the Wetlands and Subaqueous Lands Section within ten (10) days of completion of the dredging by completing and submitting the enclosed Contractor's Post Construction Completion Report form.

SPECIAL CONDITIONS (Water Quality Certification)

1. All dredging and filling are to be conducted in a manner consistent with sound conservation and water pollution control practices. Spoils and fill areas are to be contained in a manner that prevents the entrance of the dredged material into any surface water or wetland.
2. The work authorized herein shall be completed in accordance with the terms and conditions of the Department of the Army Individual Permit CENAP-OP-R-2016-1049-23.

IN WITNESS WHEREOF, I, Steven M. Smailer, the duly authorized representative of Shawn M. Garvin, Secretary of the Department of Natural Resources and Environmental Control, have hereunto set my hand this 2nd day of February, 2021.

By Steven M. Smailer, Environmental Program Administrator
the duly authorized representative of the Secretary of the
Department of Natural Resources and Environmental Control

Zach Messick, Environmental Scientist
Wetlands and Subaqueous Lands Section



STATE OF DELAWARE
 DEPARTMENT OF NATURAL RESOURCES AND
 ENVIRONMENTAL CONTROL
 DIVISION OF WATER
 RICHARDSON & ROBENS BUILDING
 89 KINGS HIGHWAY
 DOVER, DELAWARE 19901

WETLANDS &
 SUBAQUEOUS LANDS

PHONE
 (302) 739-9943

**SUBAQUEOUS LANDS PERMIT
 CONTRACTOR'S COMPLETION REPORT
 POST-CONSTRUCTION**

Subaqueous Lands Permit Number: SP/WE/WQ-302/20

Name: Pilottown Marina, Inc.

Address: At the intersection of Pilottown
 Road & Marina Drive, Lewes, DE 19958

Parcel #: 3-35-4.19-98.00

*I hereby certify that I have constructed the project authorized by the above-referenced
 Subaqueous Lands Permit in accordance with the approved plans for the project.*

Printed Name of Contractor

Name of Company

Contractor's Signature

Date

Telephone Number

Upon completion of construction, this form shall be completed, signed by the contractor, and
 mailed to the Wetlands and Subaqueous Lands Section at:

**DNREC
 Wetlands and Subaqueous Lands Section
 89 Kings Highway
 Dover, Delaware 19901**

Or faxed to the Wetlands and Subaqueous Lands Section at: 302-739-6304

*This form must be received by the Department within ten days of the date that
 construction is completed.*

For official use only

Compliance inspection date _____ *Built in accordance with plans* Yes No

Scientist: _____

Affix
Proper
Postage
Here

Mail to:

DNREC – Wetlands and Subaqueous Lands Section
89 Kings Highway
Dover, DE 19901



WETLANDS AND SUBAQUEOUS LANDS SECTION

PERMIT NO.: SP/WE/WQ-302/20

CONSTRUCTION EXPIRATION DATE: 2/2/2024

FOR THE FOLLOWING ACTIVITIES:

- To hydraulically maintenance dredge to a depth of -6 feet MLW, removing up to 4,035 cubic yards of material.
- To temporarily place a 12-inch diameter pipeline across approximately 120 linear feet of State-regulated tidal wetlands.
- To hydraulically pump up to 4,035 cubic yards of material to an Army Corps of Engineers upland, confined disposal facility, located approximately 1,100 feet east of the dredging location.

LOCATED ON PUBLIC SUBAQUEOUS LANDS AND STATE-REGULATED WETLANDS:

In the Lewes and Rehoboth Canal
At Pilottown Marina
At the intersection of Pilottown Road & Marina Drive
Lewes, Sussex County, Delaware

ISSUED TO: Pilottown Marina, Inc.

LOCATION OF WORK: Same as above

DISPLAY THIS CERTIFICATE IN A HIGHLY

VISIBLE LOCATION ON THE JOB SITE.

Authorized

by: _____

**PROPOSED HYDRAULIC MAINTENANCE
DREDGING (4,035+ C.Y.) TO -6' MLW**

IN: Pilottown Marina, adjacent to
Lewes and Rehoboth Canal
AT: Pilottown Road at Marina Drive
Lewes, Sussex County, DE 19958
Tax Map Parcel #3-35-4, 19-98, 00
APPLICANT: Pilottown Marina, Inc.
DATE: August 12, 2020

**W.S.L.S.
APPROVED PLANS**

PERMIT #: SP/WE-302
DATE: 01/21/2021
BY: Zach Messick
(SEE PERMIT CONDITIONS)

**Delaware
State Park
Lands**

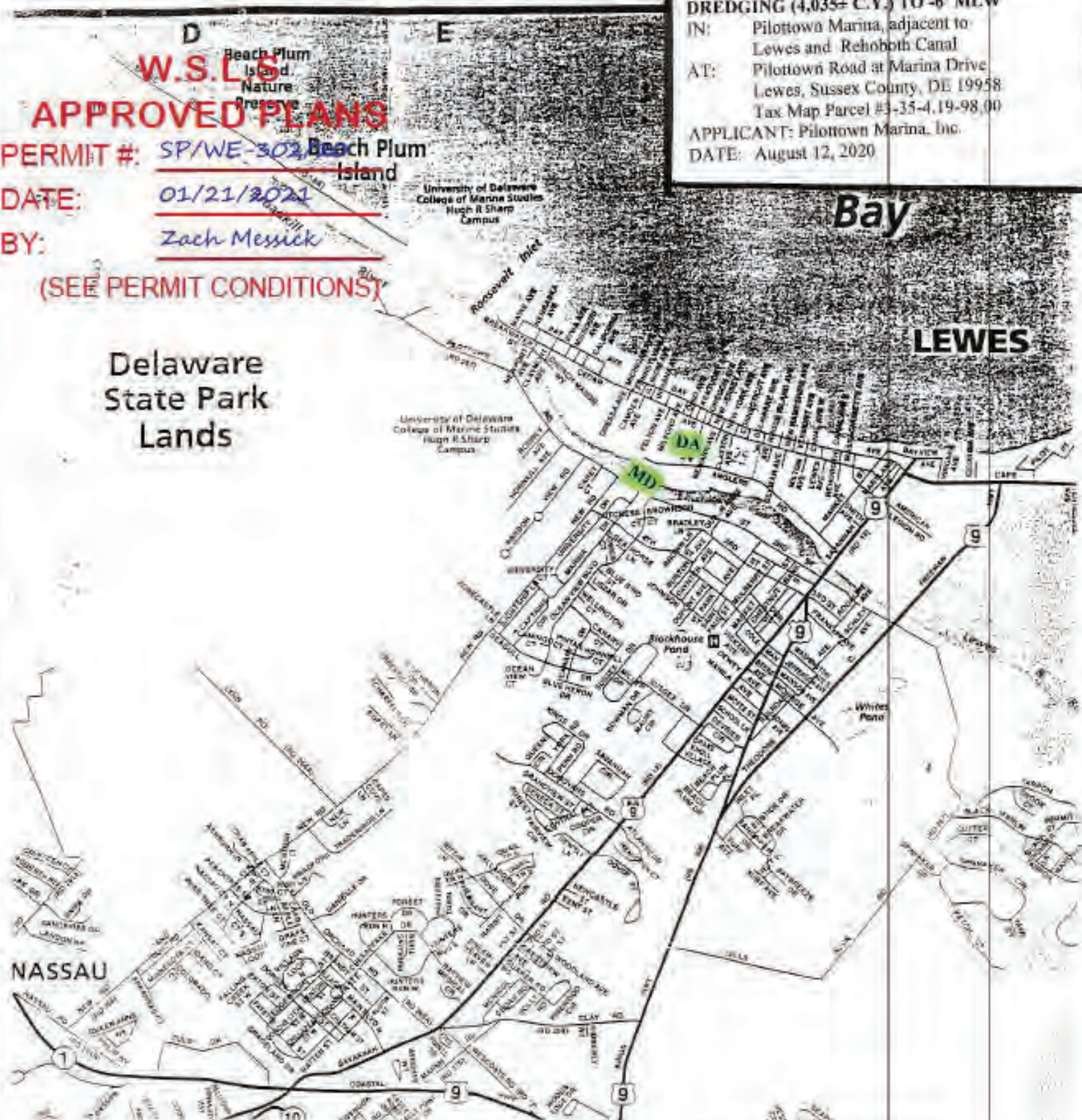

Figure 2. Map of Lewes and vicinity, Delaware, showing maintenance dredging (MD) site, Pilottown Marina, Pilottown Road, Lewes; and disposal area (DA) west of Anglers Road, Lewes Beach. Directions to Pilottown Marina (From Dover, DE): SR-1 southbound toward Lewes; left turn (cross northbound lanes) then right onto Nassau Road; left onto New Road to end; right onto Pilottown Road; marina is on left, across from Marina Drive. Directions to disposal area: Exit marina and turn left onto Pilottown Road; left at traffic light onto Savannah Road; cross Lewes and Rehoboth Canal drawbridge; left onto Cedar Street; left onto Newark Avenue to end. Disposal site is across wooded berm at end of street. Also see Figure 1.

**PROPOSED HYDRAULIC MAINTENANCE
DREDGING (4,035 C.Y.) TO -6' MLW**
 IN: Pilottown Marina, adjacent to
 Lewes and Rehoboth Canal
 AT: Pilottown Road at Marina Drive
 Lewes, Sussex County, DE 19958
 Tax Map Parcel #3-35-4.19-98.00
 APPLICANT: Pilottown Marina, Inc.
 DATE: August 12, 2020



**W.S.L.S
APPROVED PLANS**

PERMIT #: SP/WE-302/20

DATE: 01/21/2021

BY: Zach Messick

(SEE PERMIT CONDITIONS)

Figure 3. Maintenance dredging site location, Pilottown Marina, Tax Map Parcel #3-35-4.19-98.00 (Pilottown Road at Marina Drive, Lewes, Sussex County, Delaware). Disposal site is across waterway (Tax Map Parcel #3-35-4.19-67.00). Adjacent property owners:

<u>Tax Map Parcel #</u>	<u>Name, address of owner</u>
#3-35-4.18-83.00	G. Lawrence Adams, P.O. Box 88, Lewes, DE 19958
#3-35-4.19-102.00	Lambert's Cove, 409 Pilottown Road, Lewes DE 19 958



Figure 4. USGS topographic map, Lewes, Delaware, showing locations of maintenance dredging (MD) site and disposal area (DA), adjacent to Lewes and Rehoboth Canal, Lewes, Delaware. Scale: 1" = 2,000'

W.S.L.S
APPROVED PLANS

PERMIT #: SP/WE-302/20

DATE: 01/21/2021

BY: Zach Messick

PROPOSED HYDRAULIC MAINTENANCE
DREDGING (4,035± C.Y.) TO -6' MLW

IN: Pilottown Marina, adjacent to
Lewes and Rehoboth Canal

AT: Pilottown Road at Marina Drive
Lewes, Sussex County, DE 19958
Tax Map Parcel #3-35-4.19-98.00

APPLICANT: Pilottown Marina, Inc.

DATE: August 12, 2020

(SEE PERMIT CONDITIONS)

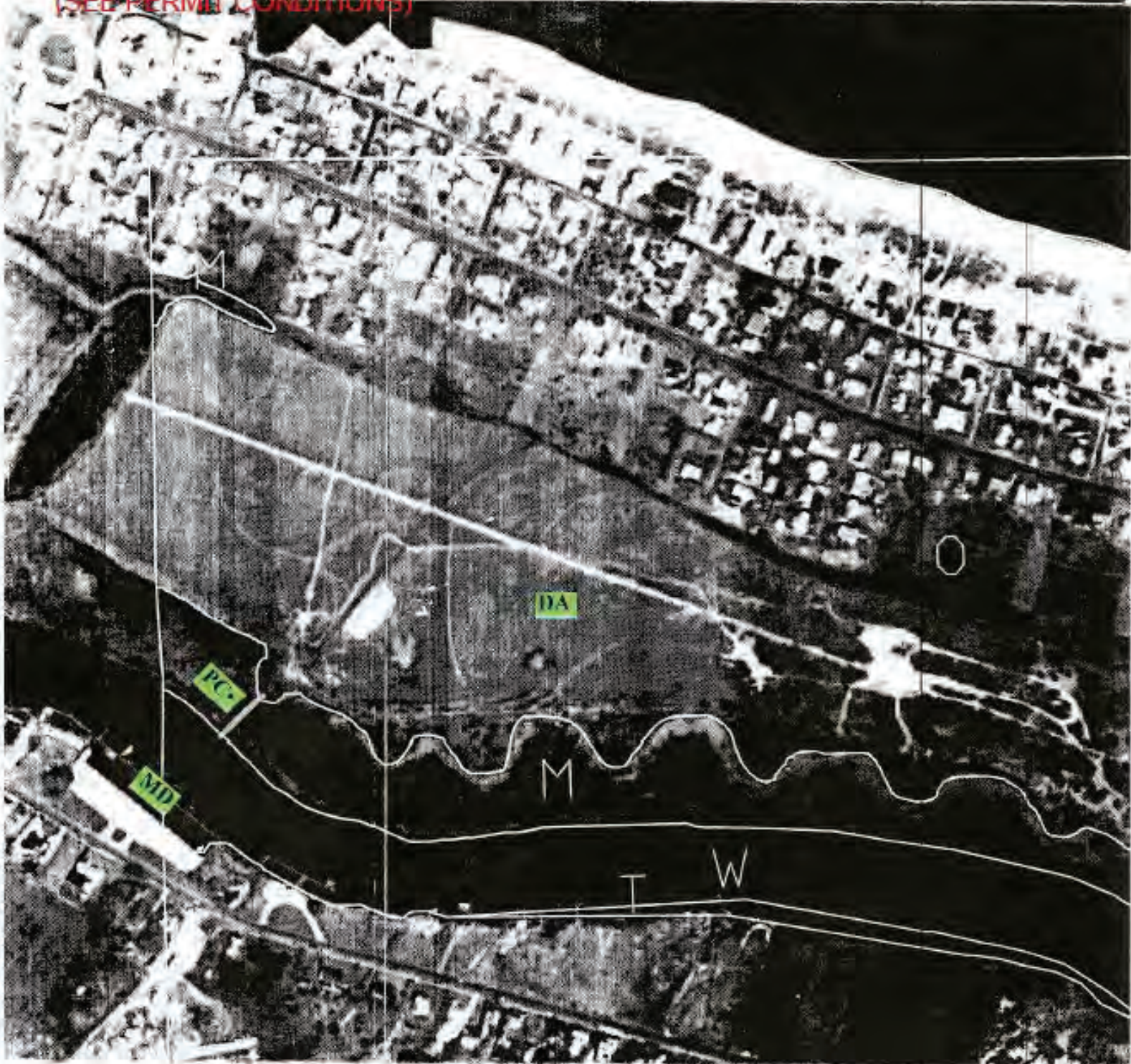

Figure 5. State of Delaware DNREC Wetland Map #DNR066 showing locations of maintenance dredging (MD) site; hydraulic pipeline crossing (PC); and disposal area (DA). Hydraulic pipeline will cross approximately 120' of *Spartina alterniflora* marsh (mapped "M") to access upland disposal area. Scale: 1" = 300'.

W.S.L.S

APPROVED PLANS

PERMIT #: SP/WE-302/20

DATE: 01/21/2021

BY: Zach Messick

(SEE PERMIT CONDITIONS)



DREDGING (4,035± C.Y.) TO -6' MLW

IN: Pilottown Marina, adjacent to
Lewes and Rehoboth Canal
AT: Pilottown Road at Marina Drive
Lewes, Sussex County, DE 19958
Tax Map Parcel #3-35-4.10-08.00

APPLICANT: Pilottown Marina, Inc.

DATE: August 12, 2020



Imagery ©2020 Maxar Technologies, U.S. Geological Survey, USDA Farm Service Agency, Map data ©2020 100 ft

Figure 6. Aerial photograph showing Pilottown Marina (maintenance dredging site, MD), adjacent to Lewes and Rehoboth Canal; disposal area (DA); and pipeline crossing (PC).



Figure 7. Photograph of Pilottown Marina (maintenance dredging site), marina basin adjacent to Lewes and Rehoboth Canal, Pilottown Road, Lewes, Delaware.

PROPOSED HYDRAULIC MAINTENANCE
 DREDGING (4,035± C.Y.) TO -6' MLW
 IN: Pilottown Marina, adjacent to
 Lewes and Rehoboth Canal
 AT: Pilottown Road at Marina Drive
 Lewes, Sussex County, DE 19958
 Tax Map Parcel #3-35-4.19-98.00
 APPLICANT: Pilottown Marina, Inc.
 DATE: August 12, 2020

W.S.L.S
APPROVED PLANS
 PERMIT #: SP/WE-302/20
 DATE: 01/21/2021
 BY: Zach Messick
 (SEE PERMIT CONDITIONS)

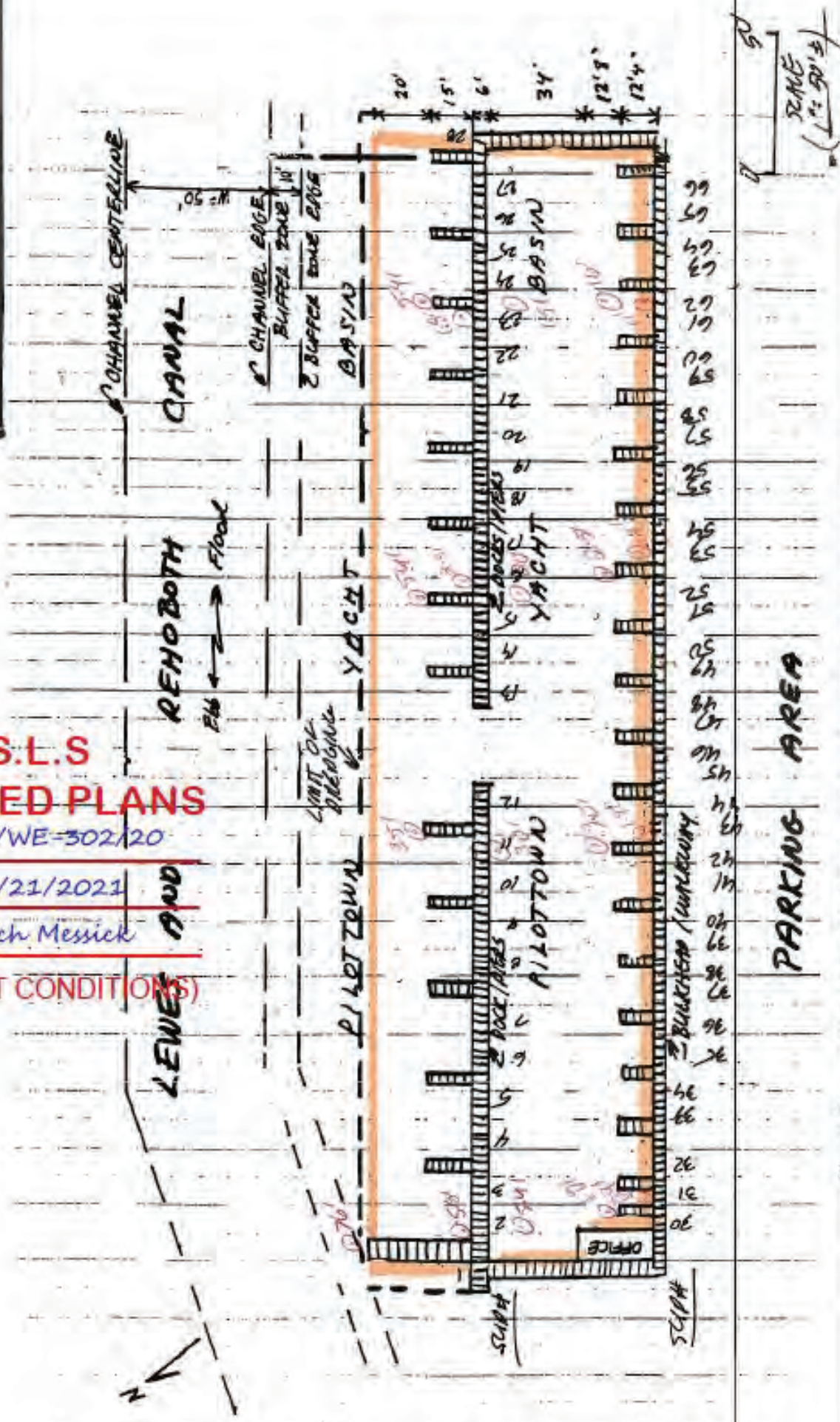

Figure 8a. Plan view of Pilottown Marina showing area to be dredged, and representative existing mean low water (MLW) depths as measured on site on June 19, 2020 by Evelyn Maurmeyer, CER, Inc. (adjusted to MLW). See Figure 8b for cross-

Pilottown Marina PermitPlans

Final Audit Report

2021-02-03

Created:	2021-02-03
By:	Zachary Messick (Zachary.Messick@delaware.gov)
Status:	Signed
Transaction ID:	CBJCHBCAABAA3HC11WmB14YxdnvOausCeTCSfqj1V-D2

"Pilottown Marina PermitPlans" History

-  Document created by Zachary Messick (Zachary.Messick@delaware.gov)
2021-02-03 - 0:52:37 AM GMT- IP address: 174.198.211.203
-  Document emailed to Steven Smailer (steven.smailer@delaware.gov) for signature
2021-02-03 - 0:54:21 AM GMT
-  Email viewed by Steven Smailer (steven.smailer@delaware.gov)
2021-02-03 - 1:41:01 PM GMT- IP address: 104.47.65.254
-  Document e-signed by Steven Smailer (steven.smailer@delaware.gov)
Signature Date: 2021-02-03 - 1:41:36 PM GMT - Time Source: server- IP address: 167.21.141.35
-  Agreement completed.
2021-02-03 - 1:41:36 PM GMT

Pilottown Marina
2016 USACE Permit (CENAP-OP-R-2016-1049-23)



REPLY TO
ATTENTION OF

CERTIFIED MAIL-RETURN RECEIPT REQUESTED

DEPARTMENT OF THE ARMY

PHILADELPHIA DISTRICT CORPS OF ENGINEERS
WANAMAKER BUILDING, 100 PENN SQUARE EAST
PHILADELPHIA, PENNSYLVANIA 19107-3390

FEB 22 2017

Regulatory Branch
Applications Section I

SUBJECT: CENAP-OP-R-2016-1049-23 (Final IP)
Pilottown Marina Maintenance Dredging SX
38.7803N/-75.15002W

Mr. Theodore Becker
Pilottown Marina Incorporated
Post Office Box 101
Lewes, Delaware 19958

Dear Mr. Becker:

Enclosed is a Department of the Army Permit (Enclosure 1) authorizing Pilottown Marina Incorporated to conduct hydraulic maintenance dredging adjacent to the Lewes and Rehoboth Canal at the Pilottown Marina basin, Tax Map Parcel 3-35-4.19-98.00, City of Lewes, Sussex County, Delaware. Also enclosed is a notice of authorization (ENG Form 4336-Enclosure 2) to be conspicuously displayed at the site of work.

Carefully review all the terms and conditions of the Department of the Army permit and understand them fully. Performing any work not specifically authorized by the permit or failing to comply with its conditions may subject you and/or your contractor to the enforcement provisions of our regulations. If a contractor performs the work for you, both you and the contractor are responsible for assuring the work is done in conformance with the conditions and limitations of this permit. Please be sure the person who will do the work has read and understands the conditions of the permit.

This office shall be notified of the commencement and completion of the permitted work. To assist you in meeting this requirement, enclosed with the Department of the Army Permit is a Notification/Certification of Work Commencement Form and a Notification/Certification of Work Completion/ Compliance Form (Enclosures 3 and 4) which must be signed and returned to this office. Additional information concerning this permit may be obtained by writing to John Brundage of my office at the above address or calling between the hours of 1:00 and 3:30 p.m. at 302-736-9763.

If any material changes in the location or plans of the permitted work are found necessary on account of unforeseen or altered conditions or otherwise, revised plans should be submitted promptly to this office in order that the revised plans, if found unobjectionable, may receive the approval required by law before operations on the permitted work are commenced.

Sincerely,

A handwritten signature in cursive script, appearing to read "Edward E. Bonner".

Edward E. Bonner
Chief, Regulatory Branch

Enclosures

DEPARTMENT OF THE ARMY PERMIT

PERMITTEE AND PERMIT NUMBER:

PERMITTEE: Pilottown Marina, Incorporated
CENAP-OP-R-2016-1049-23

ISSUING OFFICE:

Department of the Army
U.S. Army Corps of Engineers, Philadelphia District
Wanamaker Building - 100 Penn Square East
Philadelphia, Pennsylvania 19107-3390

NOTE: The term "you" and its derivatives, as used in this permit, means the permittee or any future transferee. The term "this office" refers to the appropriate district or division office of the Corps of Engineers having jurisdiction over the permitted activity or the appropriate official of that office acting under the authority of the commanding officer.

You are authorized to perform work in accordance with the terms and conditions specified below.

PROJECT DESCRIPTION: To conduct hydraulic maintenance dredging adjacent to the Lewes and Rehoboth Canal at the Pilottown Marina basin, Tax Map Parcel 3-35-4.19-98.00, City of Lewes, Sussex County, Delaware. All work is to be completed in accordance with the attached plans E-1 through E-4.

PROJECT LOCATION: Tax Map Parcel 3-35-4.19-98.00, City of Lewes, Sussex County, Delaware.

PERMIT CONDITIONS:

General Conditions:

1. The time limit for completing the work authorized ends on 31 December 2027. If you find that you need more time to complete the authorized activity, submit your request for a time extension to this office for consideration at least one month before the above date is reached.
2. You must maintain the activity authorized by this permit in good condition and in conformance with the terms and conditions of this permit. You are not relieved of this requirement if you abandon the permitted activity, although you may make a good faith transfer to a third party in compliance with General Condition 4 below. Should you wish to cease to maintain the authorized activity or should you desire to abandon it without a good faith transfer, you must obtain a modification of this permit from this office, which may require restoration of the area.
3. If you discover any previously unknown historic or archeological remains while accomplishing

the activity authorized by this permit, you must immediately notify this office of what you have found. We will initiate the Federal and State coordination required to determine if the remains warrant a recovery effort or if the site is eligible for listing in the National Register of Historic Places.

4. If you sell the property associated with this permit, you must obtain the signature of the new owner in the space provided and forward a copy of the permit to this office to validate the transfer of this authorization.
5. If a conditioned water quality certification has been issued for your project, you must comply with conditions specified in the certification as special conditions to this permit.
6. You must allow representatives from this office to inspect the authorized activity at any time deemed necessary to ensure that it is being or has been accomplished in accordance with the terms and conditions of your permit.

Special Conditions:

1. All work performed in association with the above noted project shall be conducted in accordance with the project plans identified as E-1 through E-4. The project plans illustrate a proposal to conduct hydraulic maintenance dredging adjacent to the Lewes and Rehoboth Canal at the Pilottown Marina basin, Tax map Parcel 3-35-4.19-98.00, City of Lewes, Sussex County, Delaware. The stated purpose of the project is to maintain safe navigable depths within the existing Pilottown Marina basin.
2. Any deviation in construction methodology or project design from that shown on the above noted drawings must be approved by this office, in writing, prior to performance of the work. All modifications to the above noted project plans shall be approved, in writing, by this office. No work shall be performed prior to written approval of this office.
3. This office shall be notified at least 10 days prior to the commencement of authorized work by completing and signing the attached *Notification/ Certification of Work Commencement Form*. This office shall also be notified within 10 days of the completion of the authorized work by completing and signing the attached *Notification/Certification of Work Completion/Compliance Form*. All notifications required by this condition shall be in writing and shall be transmitted to this office by registered mail. Oral notifications are not acceptable. Similar notification is required each time maintenance work is to be done under the terms of this Corps of Engineers permit.
4. The permittee understands and agrees that, if future operations by the United States require the removal, relocation, or other alteration, of the structure or work herein authorized, or if, in the opinion of the Secretary of the Army or his authorized representative, said structure or work shall cause unreasonable obstruction to the free navigation of the navigable waters, the permittee will be required, upon due notice from the Corps of Engineers, to remove, relocate, or alter the structural work or obstructions caused thereby, without expense to the United States. No claim shall be made against the United States on account of any such removal or alteration. (This special condition is applicable to Corps of Engineers permits that provide authorization under Section 10 of the Rivers and Harbors Act of 1899.)

5. Representatives of the U.S. Army Corps of Engineers shall be permitted to inspect the project during its phase of construction, and to collect any samples, or to conduct any tests deemed necessary.
6. The permittee is responsible for ensuring that the contractor and/or workers executing the activity(s) authorized by this permit have knowledge of the terms and conditions of the authorization and that a copy of the permit document is at the project site throughout the period the work is underway.
7. This permit authorizes maintenance dredging for a period of ten years terminating on 31 December 2027 provided the dredging method, location, depth and disposal site remain unchanged. The Corps of Engineers shall be notified before any subsequent maintenance dredging takes place. The dredging depth shall not exceed the previously authorized depth for this site.
8. In order to minimize impacts to juvenile summer flounder, the dredging activity authorized by this permit shall not occur from March 1 through September 30 of any year. All dredging shall take place between October 1 and the last day of February.
9. All dredged material shall be disposed of at the approved upland confined disposal site identified on Plans E-1 and E-2, and shall be appropriately contained in order to preclude its escape to adjoining areas.
10. Prior to disposal of the dredged material into the disposal site, the permittee shall obtain a Real Estate instrument from the Baltimore District, U.S. Army Corps of Engineers, ATTN: CENAB-RE-C, P.O. Box 1715, Baltimore, Maryland (410) 962-4649. All work shall be performed in accordance with the terms and conditions of the Real Estate instrument.
11. Upon receipt of the above referenced Real Estate instrument, a copy of the instrument shall be forwarded to the U.S. Army Corps of Engineers, Regulatory Branch: 1203 College Park Drive, Suite 103, Dover, Delaware 19904.
12. The permittee shall maintain adequate surveillance of the dredging/ disposal operations to assure that the banks used to confine the dredged material are safe from failure and that the disposal area is not used beyond capacity.
13. This permit does not obviate the permittee from obtaining any State or local assent required by law for the activity authorized.

FURTHER INFORMATION:

1. Congressional Authorities: You have been authorized to undertake the activity described above pursuant to:
 - X Section 10 of the Rivers and Harbors Act of 1899 (33 U.S.C. 403).
 - X Section 404 of the Clean Water Act (33 U.S.C. 1344).

Section 103 of the Marine Protection, Research and Sanctuaries Act.

2. Limits of this authorization.

a. This permit does not obviate the need to obtain other Federal, State, or local authorizations required by law.

b. This permit does not grant any property rights or exclusive privileges.

c. This permit does not authorize any injury to the property or rights of others.

d. This permit does not authorize interference with any existing or proposed Federal projects.

3. Limits of Federal Liability. In issuing this permit, the Federal Government does not assume any liability for the following:

a. Damages to the permitted project or uses thereof as a result of other permitted or unpermitted activities or from natural causes.

b. Damages to the permitted project or uses thereof as a result of current or future activities undertaken by or on behalf of the United States in the public interest.

c. Damages to persons, property, or to other permitted or unpermitted activities or structures caused by the activity authorized by this permit.

d. Design or construction deficiencies associated with the permitted work.

e. Damage claims associated with any future modification, suspension, or revocation of this permit.

4. Reliance on Applicant's Data. The determination of this office that issuance of this permit is not contrary to the public interest was made in reliance on the information you provided.

5. Reevaluation of Permit Decision. This office may reevaluate its decision on this permit at any time the circumstances warrant. Circumstances that could require a reevaluation include, but are not limited to, the following:

a. You fail to comply with the terms and conditions of this permit.

b. The information provided by you in support of your permit application proves to have been false, incomplete, or inaccurate (see 4 above).

c. Significant new information surfaces which this office did not consider in reaching the original public interest decision.

Such a reevaluation may result in a determination that it is appropriate to use the suspension, modification, and revocation procedures contained in 33 CFR 325.7 or enforcement procedures such

as those contained in 33 CFR 326.4 and 326.5. The referenced enforcement procedures provide for the issuance of an administrative order requiring you to comply with the terms and conditions of your permit and for the initiation of legal action where appropriate. You will be required to pay for any corrective measures ordered by this office, and if you fail to comply with such directive, this office may in certain situations (such as those specified in 33 CFR 209.170) accomplish the corrective measures by contract or otherwise and bill you for the cost.

6. Extensions. General Condition 1 establishes a time limit for the completion of the activity authorized by this permit. Unless there are circumstances requiring either a prompt completion of the authorized activity or a reevaluation of the public interest decision, the Corps will normally give favorable consideration to a request for an extension of this time limit.

Your signature below, as permittee, indicates that you accept and agree to comply with the terms and conditions of this permit.

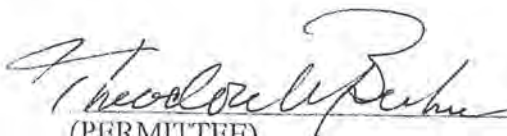
(PERMITTEE) _____ (DATE) 1/28/17

This permit becomes effective when the Federal official, designated to act for the Secretary of the Army, has signed below.

(District Engineer) _____ (DATE) Feb 22, 2017
Edward E. Bonner, Chief, Regulatory Branch

for Michael A. Bliss, P.E.
Lieutenant Colonel, Corps of Engineers
District Commander

When the structures or work authorized by this permit are still in existence at the time the property is transferred, the terms and conditions of this permit will continue to be binding on the new owner(s) of the property. To validate the transfer of this permit and the associated liabilities associated with compliance with its terms and conditions, have the transferee sign and date below.

(TRANSFEEE)

(DATE)

**PROPOSED HYDRAULIC MAINTENANCE
DREDGING (4,320 C.Y.) TO -6' MLW**

IN: Pilottown Marina, adjacent to
Lewes and Rehoboth Canal
AT: Pilottown Road at Marina Drive
Lewes, Sussex County, DE 19958
Tax Map Parcel #3-35-4.19-98.00

APPLICANT: Pilottown Marina, Inc.
DATE: July 7, 2016

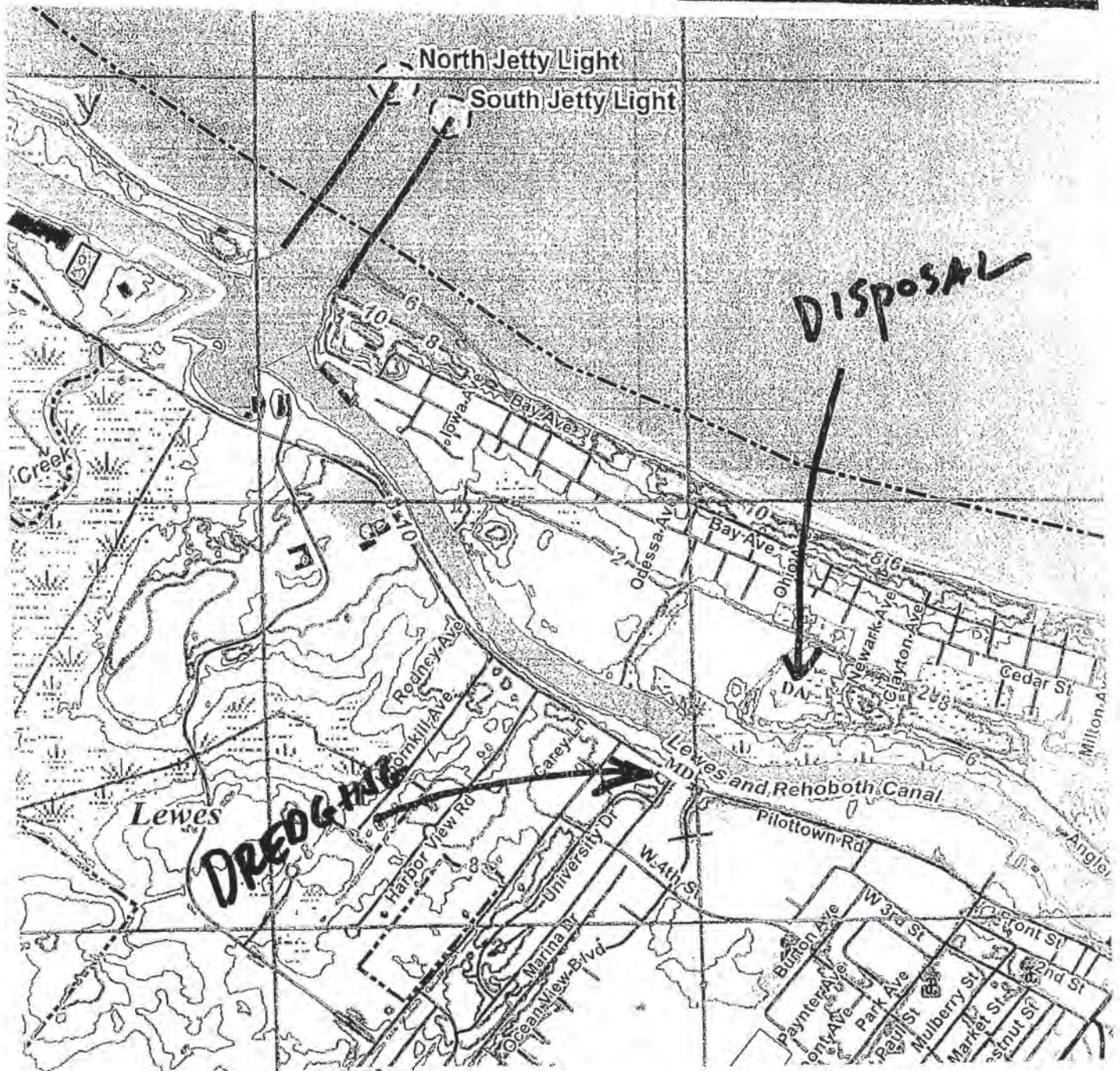

Figure 4. USGS topographic map, Lewes, Delaware, showing locations of maintenance dredging (MD) site and disposal area (DA), adjacent to Lewes and Rehoboth Canal, Lewes, Delaware. Scale: 1" = 2,000'.

E-1

**PROPOSED HYDRAULIC MAINTENANCE
DREDGING (4,320 C.Y.) TO -6' MLW**

IN: Pilottown Marina, adjacent to
Lewes and Rehoboth Canal
AT: Pilottown Road at Marina Drive
Lewes, Sussex County, DE 19958
Tax Map Parcel #3-35-4.19-98.00
APPLICANT: Pilottown Marina, Inc.
DATE: July 7, 2016

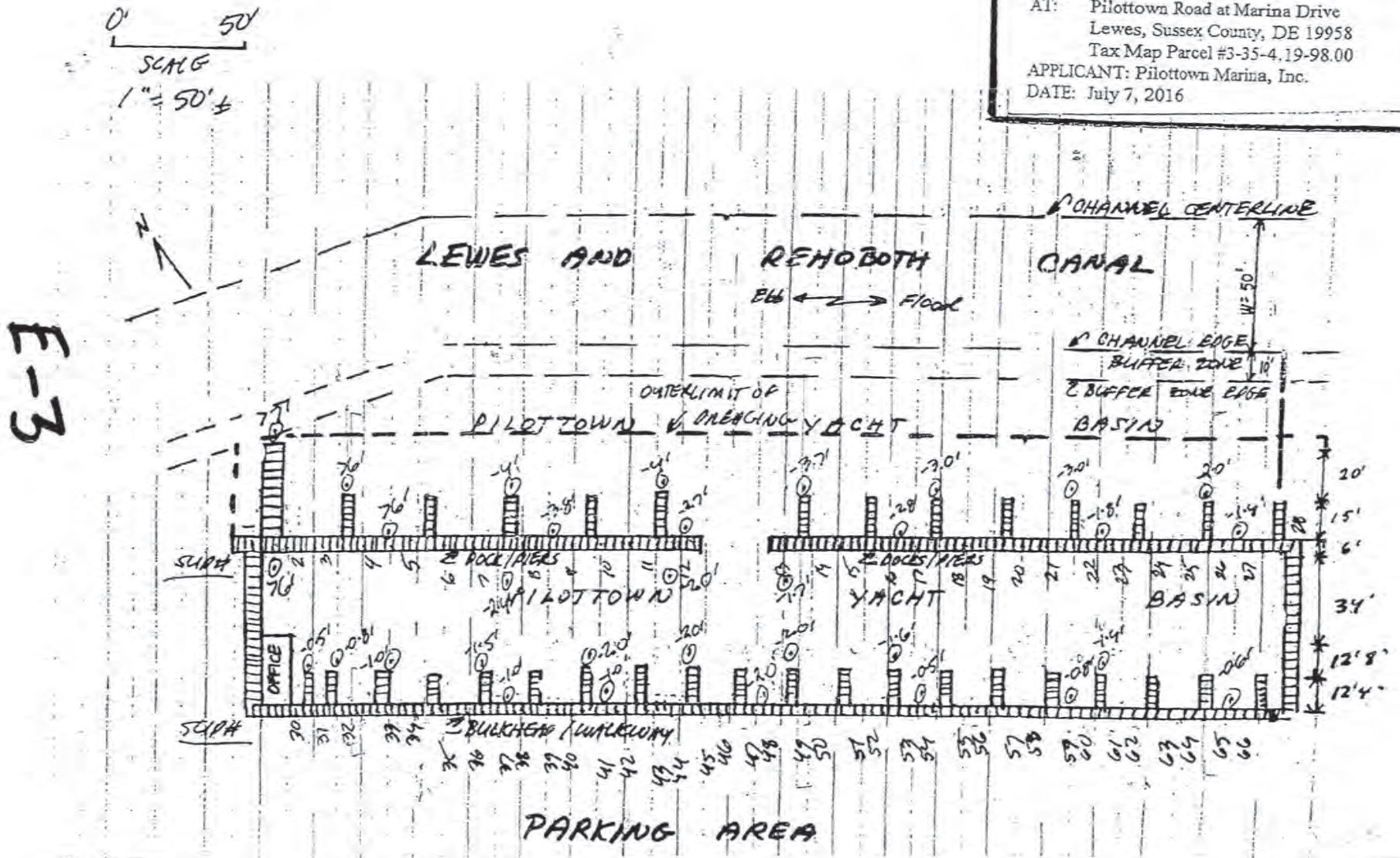

Figure 9. Plan view sketch of Pilottown Marina showing area to be dredged, and representative existing mean low water (MLW) depths as measured on site, June 30, 2016 and adjusted to MLW. See Figure 10 for cross-sections.

PROPOSAL: PILOTTOWN MARINA HYDROGRAPHIC SURVEY

Proposal No. 2024-0725

Date: July 25, 2024



53 Atlantic Ave., Suite#3
 Ocean View, DE 19970
 ph: 302-222-2075
 Contact: Rob Plitko, Jr., P.E.

To:

Company
 Name
 Address
 City, State ZIP
 Phone
 Email
 Completion date



PMS
Hydrograph
7/26/24

SCOPE OF WORK

ITEM	DESCRIPTION - PROJECT WORKFLOW	COST (\$)
1	PRE-DREDGE HYDROGRAPHIC SURVEY 200 KHZ SINGLE BEAM	\$2,500

Survey work to be completed per attached Exhibit 'A'

Any work beyond the scope described above will be billed in accordance with the attached "hourly rates" and "general conditions". no additional services will be initiated without your authorization. all agency fees to be paid for by developer.

TOTAL \$2,500

COMPANY PROPOSAL

WE PROPOSE TO COMPLETE THE ABOVE SCOPE OF WORK AT A LUMP SUM FEE = \$2,500

[Signature]

7/25/2024

Submitted by (Rob Plitko, Jr., P.E.)

Date

ACCEPTED FOR THE OWNER

[Signature]
 Submitted by (Signature)

Theodore W Becker
 Printed Name

7/26/2024
 Date

Managing Partner
 Title

202-255-4675
 Phone



ted.becker@verizon.net
 Email

If acceptable, please sign and email to rplitko@plitko.com

Pilottown Marina

Limit of Survey - Exhibit A

Legend

-  Pilottown Marina
-  Pilottown Marina, LLC
-  St George Cemetery

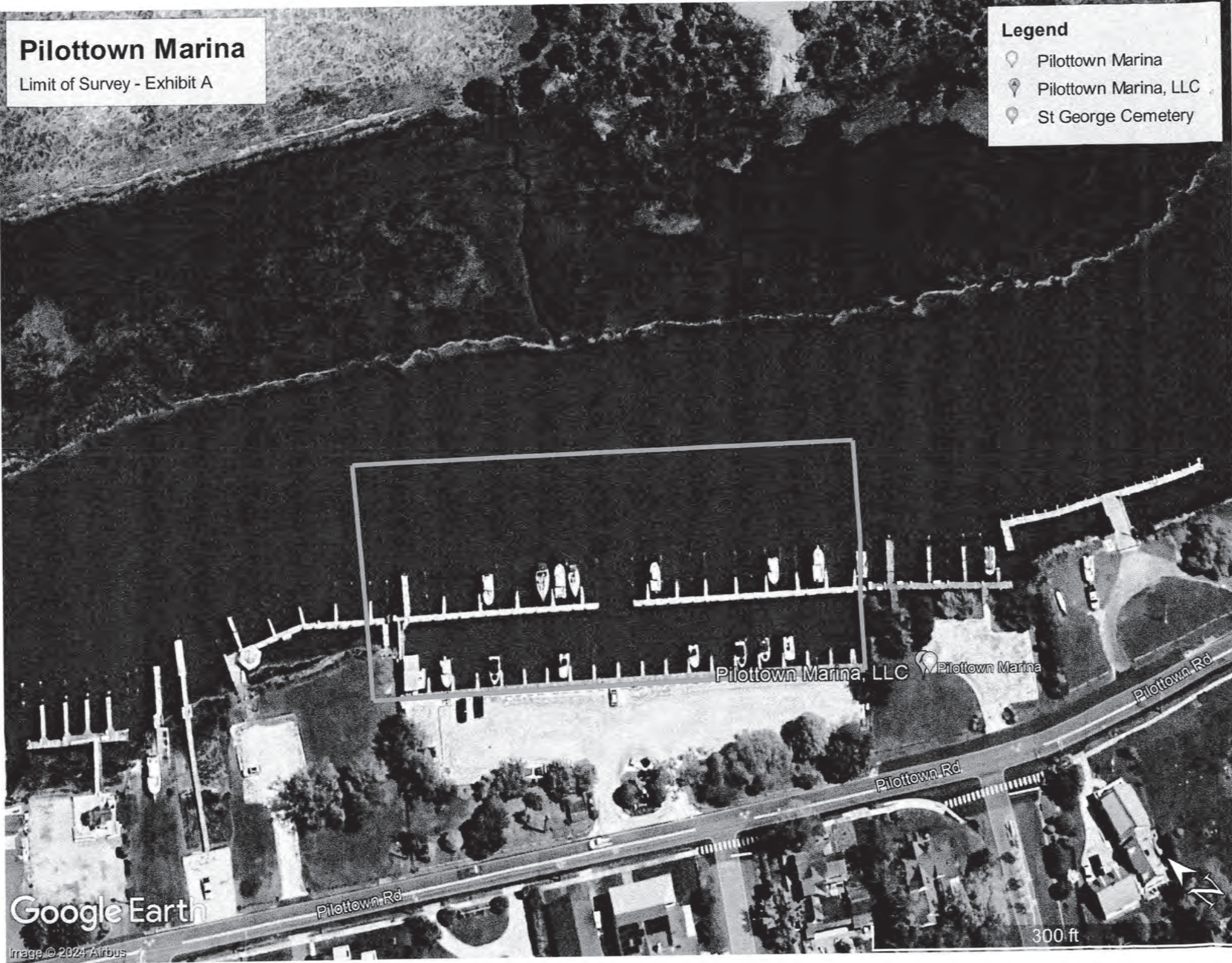

Google Earth

Image © 2024 Airbus

300 ft

Pilottown Marina
2025 Modification USACE Permit (CENAP-OP-R-2016-1049-23)



DEPARTMENT OF THE ARMY
U.S. ARMY CORPS OF ENGINEERS, PHILADELPHIA DISTRICT
1650 ARCH STREET
PHILADELPHIA PA 19103-2004

December 16, 2025

Regulatory Branch

SUBJECT: Permit Modification NAP-2016-01049-85
Pilottown Marina SX
DDNREC permit SP-302/20
Center coordinates (38.7803°N, 75.15002°W)

Theodore Becker
Pilottown Marina Incorporated
Post Office Box 101
Lewes, Delaware 19958

Dear Mr. Becker:

This is regarding your request on December 12, 2025 for a permit modification to your Department of the Army Permit. Reference is made to Standard Permit dated February 22, 2017 authorizing Pilottown Marina Incorporated to conduct hydraulic maintenance dredging at the Pilottown Marina basin with dredged material pumped into the United States Army Corps of Engineers (USACE) confined disposal facility (CDF) at the terminus of Anglers Road. This project is located in the Pilottown Marina along the Lewes and Rehoboth Canal at tax map parcel 3-35-4.19-98.00 in Lewes, Sussex County, Delaware.

The modification request includes revising the disposal method to hydraulically pump the dredged material into Geotubes for dewatering within the boundary of the Pilottown Marina parking lot with the dewatered dredged material transported to a confined upland disposal site located at 30541 Gum Road in Frankford, Sussex County, Delaware. The newly proposed disposal method and location is a result of the USACE CDF loss in availability. This is notice that your request for permit modification has been accepted and approved in accordance with 33 CFR 325.7. The following condition(s) of your permit are hereby modified:

Special Condition 9: All dredged material shall be disposed of at the approved upland confined disposal site identified on the attached plans identified as PILOTTOWN MARINA (3) 30' X 150' GEO-TUBES, 1 sheet and DREDGE DISPOSAL AREA TAX MAP: 533-5.00-31.00 30541 GUM ROAD FRANKFORD SUSEX COUNTY DELAWARE, prepared by Plitko Engineering, dated August 27, 2025, 1 sheet.

All permit conditions other than those expressly modified in this letter remain in full force and effect. Should you have questions regarding your permit, please contact Michael D. Yost at (267) 240-5278 or michael.d.yost@usace.army.mil.

BY AUTHORITY OF THE SECRETARY OF THE ARMY:

Michael D. Yost
Senior Regulatory Project Manager

For: Ryan A. Baum
Lieutenant Colonel, Corps of Engineers
District Commander





Enclosure(s)

cc:
David Small, Verdantas
Savannah Budka, Verdantas
Wetlands and Waterways Section, DDNREC

Pilottown Marina

(3) 30'x 150' Geo-Tubes.

Legend

-  Discharge Box
-  Line Measure
-  Pilottown Marina
-  Discharge Box



Google Earth

Image © 2025 Airbus



200 ft

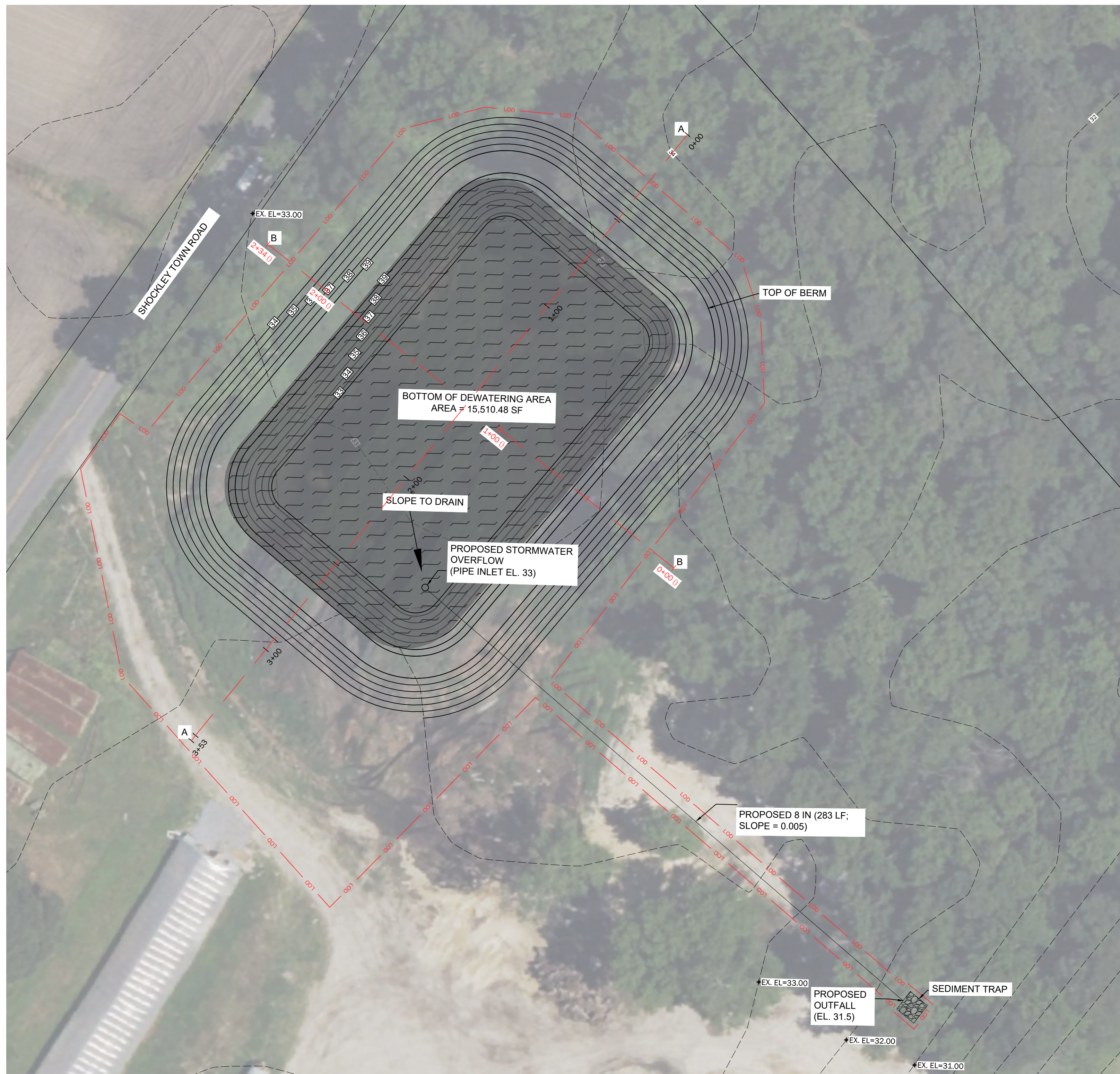

LEGEND

- LIMITS OF DISTURBANCE (1.55 AC)
- ADJACENT PROPERTY LINES
- EXISTING GRADE (BASED ON DELAWARE LIDAR DEM DATED 2014)
- STORMWATER OVERFLOW PIPE (8 IN)
- DREDGE MATERIAL DEWATERING AREA (AREA = 24,653 SF)

NOTES:

- TOTAL DREDGED MATERIAL = 3870 CY (104,490 CF) PER EXISTING PERMIT
- VOLUME OF DEWATERING AREA PROVIDED = 110,938.5 CF
- BOUNDARY SURVEY HAS NOT BEEN CONDUCTED ON THE PROJECT SITE.

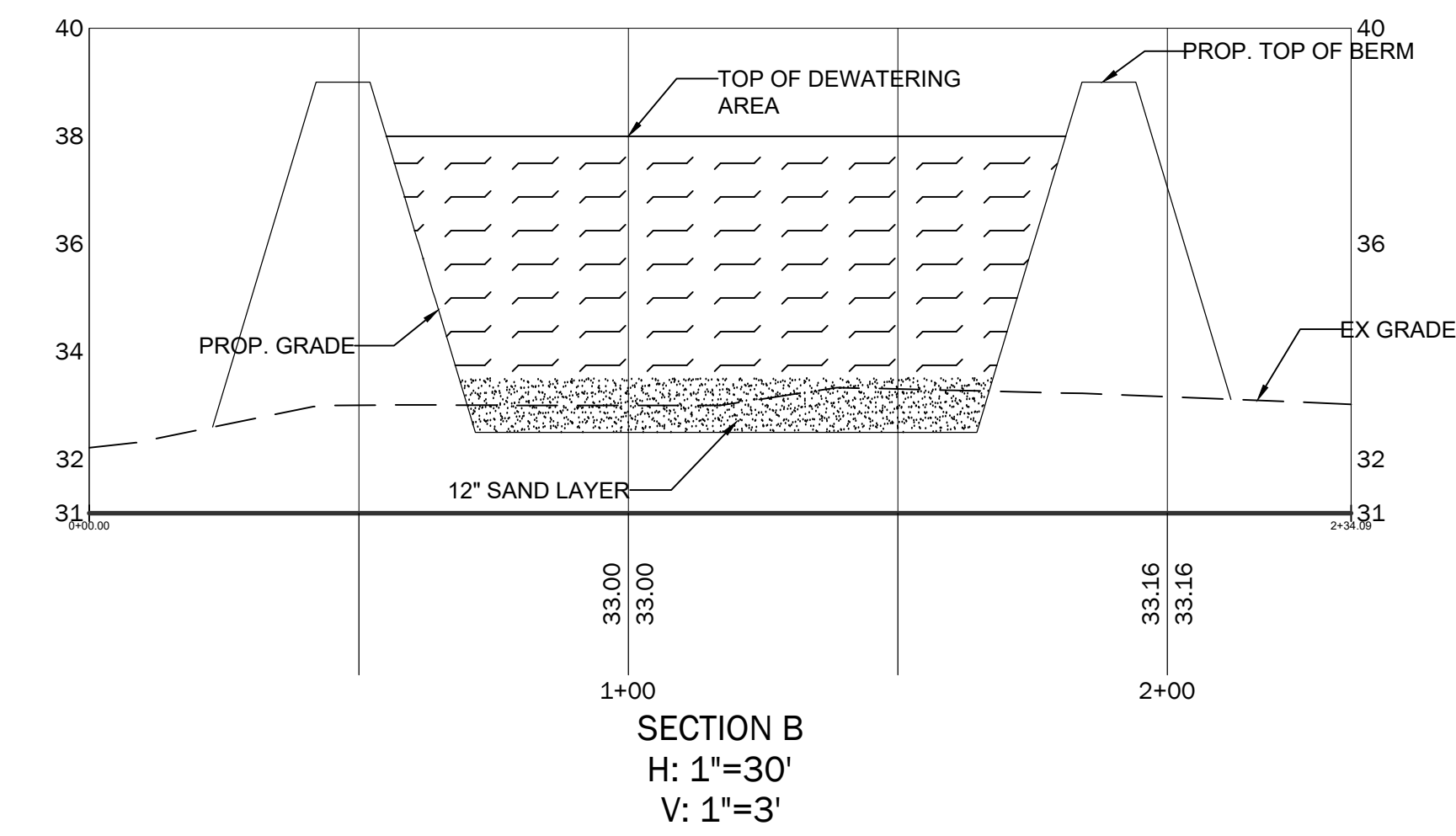
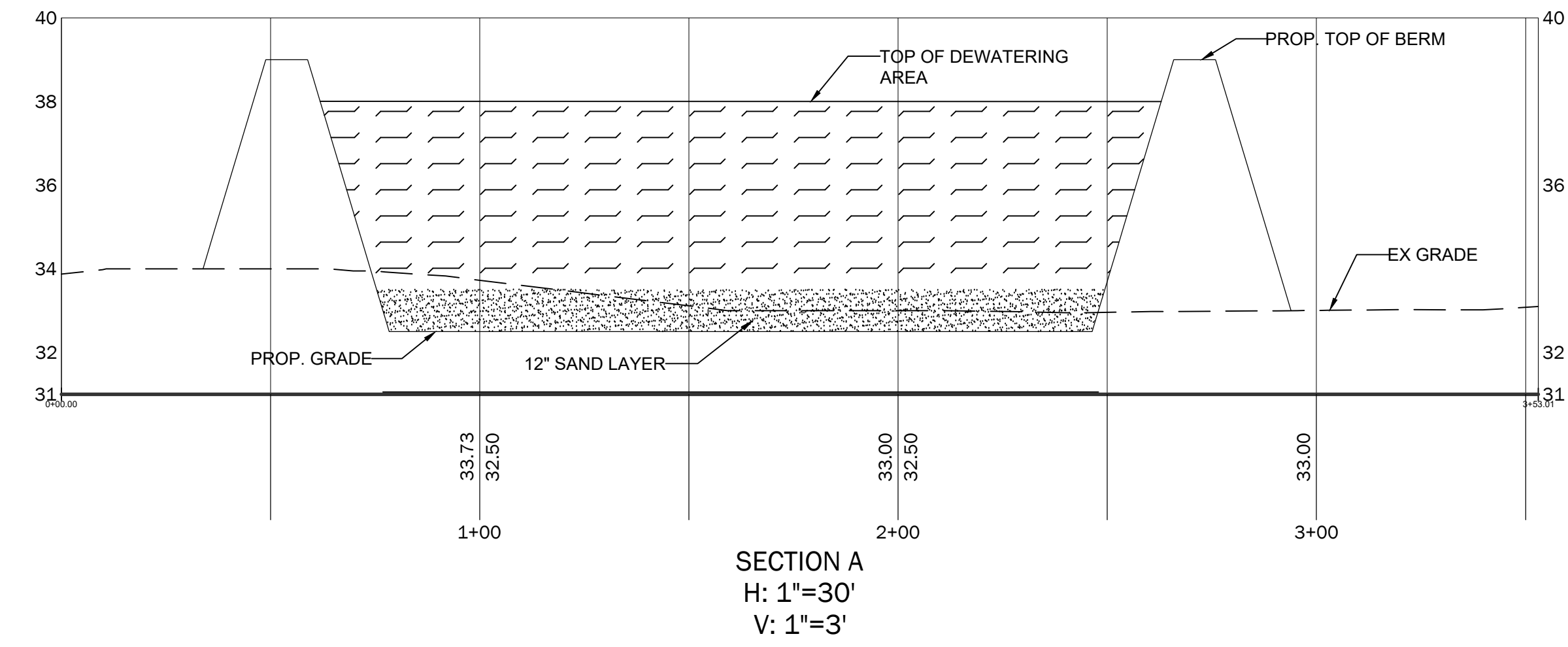

REVISIONS

PLITKO ENGINEERING
 ENGINEER - SURVEY - HYDROGRAPHIC
 53 ATLANTIC AVE., STE 3
 OCEAN VIEW, DE 19970
 Phone (302)-537-1919

DREDGE DISPOSAL AREA
 TAX MAP: 533-5.00-31.00
 30541 GUM ROAD
 FRANKFORD SUSSEX COUNTY DELAWARE

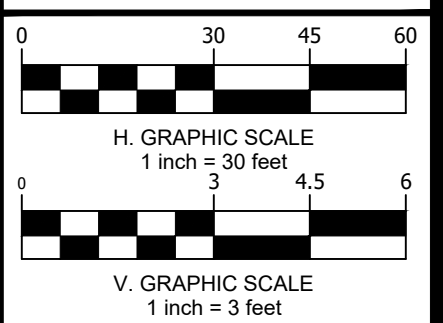

PROJECT DATUM
 HORIZONTAL: DE NAD 1983
 VERTICAL: NAVD 1988

SITE PLAN:	DATE
DRAWING:	8/27/25
REVIEW: RP	

SHEET
C100

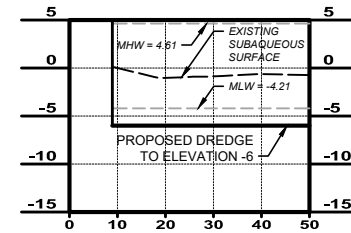
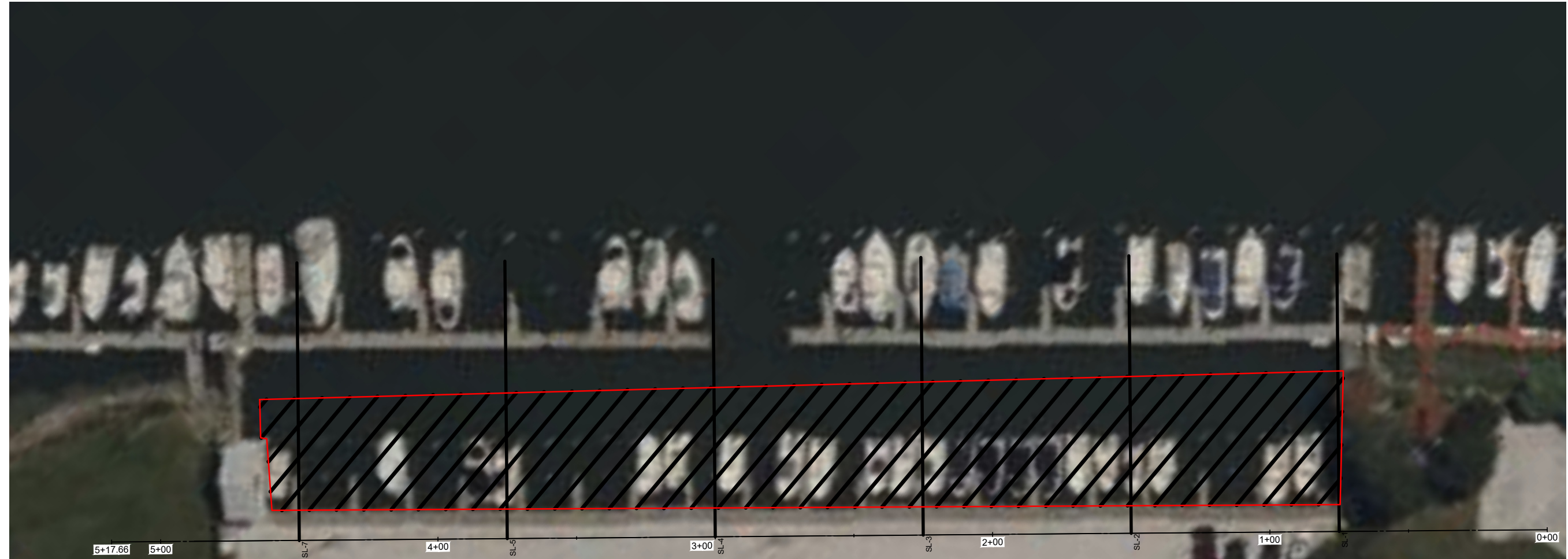

2+25.00

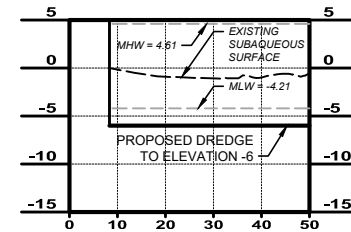

1+50.00

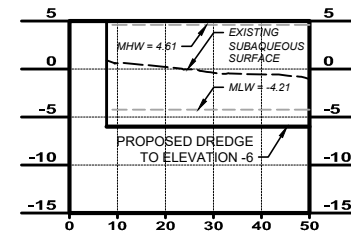

0+75.00

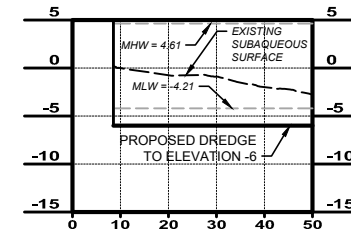

4+50.00

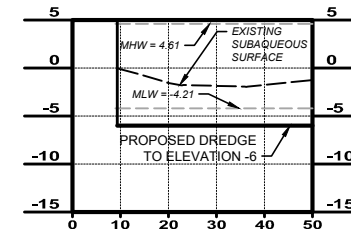

3+75.00

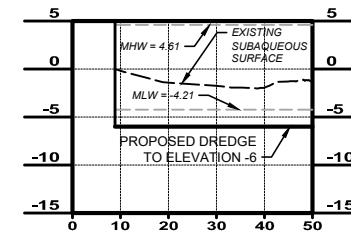

3+00.00

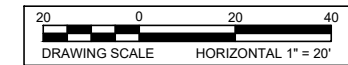
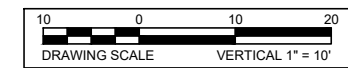
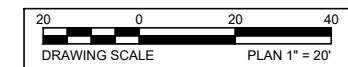

DESIGNER: Verdantas, LLC has furnished this map to the Client for its sole and exclusive use as a preliminary information only. This map is not to be used for any other purpose and is not to be relied upon for any legal or engineering purposes. The map is reproduced from geospatial information compiled from third-party sources and is not accurate as to mapping, surveying or engineering standards. Representation or warranty as to the content, accuracy, timeliness or event with Verdantas, LLC, its owners, officers, employees or agents, be liable for the use of this map by Client or any other party.

DESIGNED BY	SB
DRAWN BY	MH
CHECKED BY	DS
PROJECT NO.	28883

CHK'D BY	DATE	REVISION
MHDS	01/05/2026	REVISED TO SHOW MLW AND MHW LINES PER D.N.R.E.C.

LEWES-SUSSEX COUNTY-DELAWARE
HARBORSIDE DEVELOPMENT III, LLC
DNREC PERMIT APPLICATION
MAINTENANCE DREDGING PLAN
PLAN AND ADDITIONAL SECTIONS OF DREDGE AREA

DATE 12/30/2025

SCALE AS NOTED

SHEET 2

Z:\project\harborside\harborside\28883 - p\kbrown\mains permit\trj\plan\figs\bd\plotdown\main.mxd 12/30/2025 10:52 AM