

**Permit Number:**

**IA 282698**

**RECEIVED**

**04/22/2026**

**Division of Water**

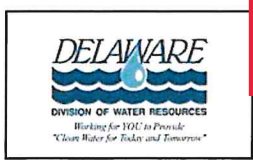

**APPLICATION - PERMIT  
ON-SITE WASTEWATER SYSTEM**



(Please Type or Print Legibly)

OWNER'S NAME: William Alexander LLC (Amy Vickers) PHONE: 302-249-4279

ADDRESS: 1208 Coastal Highway Fenwick Island, DE 19944

PROJECT LOCATION: 36678 Roaxana Road, Selbyville, DE

**PAID**  
**\$ 460.00 04/22/2026**

TAX/MAP #: 533-10.00-27.00

APPLICATION PREPARER: KENNETH R. CHRISTENBURY, P.E. DNREC LICENSE #: 4137

PREPARER'S ADDRESS: AXIOM ENGINEERING, LLC - 18 CHESTNUT STREET - GEORGETOWN, DE 19947

PHONE: 302-858-4466

I hereby affirm that the information provided on this document is accurate and complete.

Preparer's Signature: [Signature] Date: 4/22/26

By signing this permit application, the preparer further certifies they were physically present at the site.



**-SEPTIC DESIGN CRITERIA-**

(Please check all boxes that apply)

**System Type:** (CF = Cap & Fill / FD = Full Depth)

- Gravity (FD)
- Gravity (CF)
- Pressure Dose (FD)
- Pressure Dose (CF)
- Low Pressure Pipe (FD)
- Low Pressure Pipe (CF)
- Temporary Holding Tank
- Permanent Holding Tank
- Elevated Sand Mound
- Wisconsin At-Grade
- Subsurface Micro Irrigation
- Peat Bio- Filter
- Other \_\_\_\_\_

**Type of Construction:**

- Replacement
- New Construction
- Component Replacement
- Component: \_\_\_\_\_
- Repair to Existing System
- Reason: \_\_\_\_\_

- Bed or  Trench
- Gravelless Chamber  Stone/Gravel  Tire Chips
- Sand-lined  Yes  No

- Authorization to Use Existing System
- Permit #: \_\_\_\_\_
- Present Condition: \_\_\_\_\_
- Structure to be connected: \_\_\_\_\_

Existing System Malfunctioning  Yes  No  N/A

- Pre-Treatment Units
- Septic Tank
- Other MicoFast Unit 0.75

**25 Employees @  
25 GPD**

# of Bedrooms: 25 Employees  
 Avg. Percolation Rate: 80  
 Gallons Per Day Flow: 625  
 Minimum Sq. Ft. Rcq'd: 2348  
 Sq. Ft. Proposed: 2400

Central Water Available  Yes  No  
(If yes, please state Utility Name: \_\_\_\_\_)

PARID: 533-10.00-27.00  
WILLIAM ALEXANDER LLC

36678 ROXANA RD

### Property Information

---

Property Location: 36678 ROXANA RD  
 Unit:  
 City: SELBYVILLE  
 State: DE  
 Zip: 19975

Class: A-Agricultural  
 Use Code (LUC): 208-Agricultural - Ancillary Use  
 Town: 00-None  
 Tax District: 533 – BALTIMORE  
 School District: 1 - INDIAN RIVER  
 Fire District: 88-Selbyville  
 Calc'd Acres: 27.9200  
 Frontage: 0  
 Depth: .000  
 Irr Lot:  
 Plot Book Page: /PB

100% Land Value: \$0  
 100% Improvement Value: \$28,900  
 100% Total Value: \$28,900

### Legal

---

Legal Description: W/RT 52  
 445' S/RT 52C  
 FX

### Owners

---

Owner	Co-owner	Address	City	State	Zip
WILLIAM ALEXANDER LLC		1208 COASTAL HWY	FENWICK ISLAND	DE	19944

# Site Evaluation

Reference #:

573743

INNOVATIVE AND ALTERNATIVE COMMERCIAL RECEIVED

SITE EVALUATION FOR OWTDS

By ARM, INC.

APPROVAL PAGE 1 OF 3

09/26/2025

GROUNDWATER

PAID

\$ 75.00 09/26/2025

The soils on this site are approved when the following is completed in full and signed by the approving authority. The information contained in this Site Evaluation reflects Delaware Department of Natural Resources and Environmental Control (DNREC) policies and procedures at the time of the review. Exhibits and Regulations cited in this report refer to DNREC "Regulations Governing the Design, Installation, and Operation of On-Site Wastewater Treatment and Disposal Systems" (OWTDS). Isolation distance requirements, limited area of suitable soils, filling, removal, and/or compaction of the soil may negate construction permit approval or modify the type of system that can be permitted. All information should be verified by interested parties prior to design and installation of the OWTDS. This is not a construction permit. Approval of this Site Evaluation is limited to five years. Upon expiration, a new Site Evaluation will be required in compliance with Regulations in effect at the time. There are no guarantees supplemental approvals will be for the same system type (s) prescribed herein.

**Property Ownership:** William Alexander LLC

**Tax Map #:** 5-33-10.00-27.00

**Initial OWTDS Options; Provided Exhibit C isolation distances (esp. watercourse) are maintained (Minimum Isolation Distances):**

- **Option 1:** *Innovative and Alternative (I/A) \*Elevated Sand Mound with an Advanced Treatment Unit (ATU; PSN3 required) Or other applicable PSN3 \*Innovative and Alternative (I/A) Design/ Technology (i.e. Peat Fiber Biofilter with ATU recommended, Micro-Irrigation Drip with ATU, etc.) OWTDS. OR*

- **Option 2:** *\*Innovative and Alternative (I/A) Elevated Sand Mound with PSN3 Advanced Treatment Unit (ATU; PSN3 required). In the absence of a Formal Waiver or favorable outcome of wet season testing (observation wells), soils in this area do not meet the criteria for Peat Fiber Biofilter or Micro-Irrigation Drip due to the lack of a sufficient area with a 12 inch or greater limiting zone.*

**Note:** See Site Evaluator referenced *\*Site Work Preparation Requirements, \*\*Drainfield Recommendations, \*\*User Notes/ Cautions, and \*\*Drainfield Benchmarks.*

**\*Site Work Preparation Requirements – BOTH OWTDS DESIGN AREAS:** The removal of the vegetative-root-organic mat beneath drainfield entirety & basal area limits of the absorption facility is required. Plowing (8 to 12 inches bgs. recommended), as required by Regulation, is also imperative within basal limits of the drainfield to mitigate agricultural compaction (plow pan). Sand-lining is not allowable for new construction to maintain a 1 foot unsaturated, native soil thickness above the limiting zone. **\*Proctored installation by a Site Evaluator is not required, unless warranted by Installer to document site conditions or if unusual soil conditions (i.e. cuts-fills, compaction) are encountered.**

**\*\*Drainfield (Absorption Facility/ Pad) Recommendations - Site Evaluator:** *a) Where applicable, an 18 (Option 1) OR 24 (Option 2) inch minimum separation distance (drainfield/ pad/ facility invert - to limiting zone) is strongly recommended due to the degree/ persistence of saturation and soil/ site conditions (limited sidewall transmissivity with mounding potential) with the bottom of any absorption facility (i.e. Peat Fiber Biofilter module) a minimum of 6 (Option 1) OR 13 (Option 2) inches above grade or above (higher). The highest elevation should be utilized for \*\*Drainfield Benchmark in OWTDS design area to maximize the separation distance. b) Maximize the drainfield to a minimum of 1,750 square feet per 500 Gallons Per Day of Wastewater with 12 inch gravel drainfield/ pad thickness or the extent practicable. c) In the case of a Peat Fiber Biofilter with multiple modules, a setback of 10 (minimum) to 15 (optimal, especially Option 2) feet is recommended between the modules. d) The Site Evaluator is amenable to an Elevated Sand Mound with a 24 inch separation distance given the PSN3 Advanced Treatment Unit. e) A PSN3 effluent standard is required due to the Inland Bays Watershed (PCS Regulations Inland Bays; non, near-term sewer district). f) Professional collaboration with Site Evaluator is welcome at all stages of design and installation. ARM, Inc. accepts no/ limited professional liability for an OWTDS sited that is not in strict conformance with or exceeds these recommendations.*

**\*\*USER NOTES / CAUTIONS – WET SITE CONDITIONS:** Work on this property should be by experienced wastewater professionals, working during optimal soil moisture conditions, and utilizing optimum quality materials. Collaboration with the Site Evaluator is welcome to ensure a positive outcome. Please place pertinent Notes PROMINENTLY to the **Permit Construction Plan/ Conditions Pages** and make this Site Evaluation an addendum to the OWTDS-Septic Permit – *ownership's responsibility to ensure Site Evaluator Recommendations.* An OWTDS-Septic Permit is strongly recommended prior to additional site planning or financial transactions. **1)** This Site Evaluation is to site a drainfield for a proposed Cannabis Production Facility development. Mixed commercial land-use(s) discussed to date include a maximum combined wastewater volume of 1,000 gallons per day (New Construction). **2)** The OWTDS areas are shown with a **50 feet watercourse setback** (non-Shellfish Waters). **3)** **The OWTDS design area contains a fallow agricultural field with tall grasses/ weeds.** Cease construction and contact Site Evaluator if atypical soil conditions are encountered and/ or to verify the depth of drainfield-soil interface given the specific separation distances. **Note** to be placed PROMINENTLY on Permit Construction and Conditions Pages.

- Continued on Approval Page 2 -

ARM, Inc. Job # 097-DS25-CSE

LPS

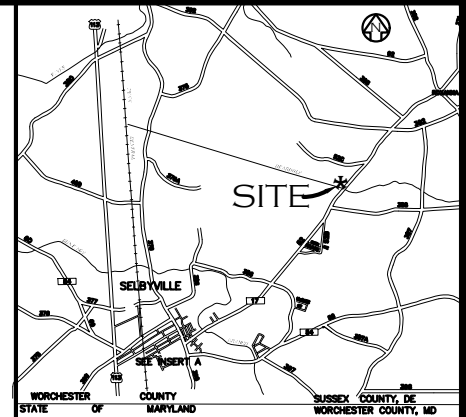

LOCATION MAP  
SCALE 1" = 2 MILE

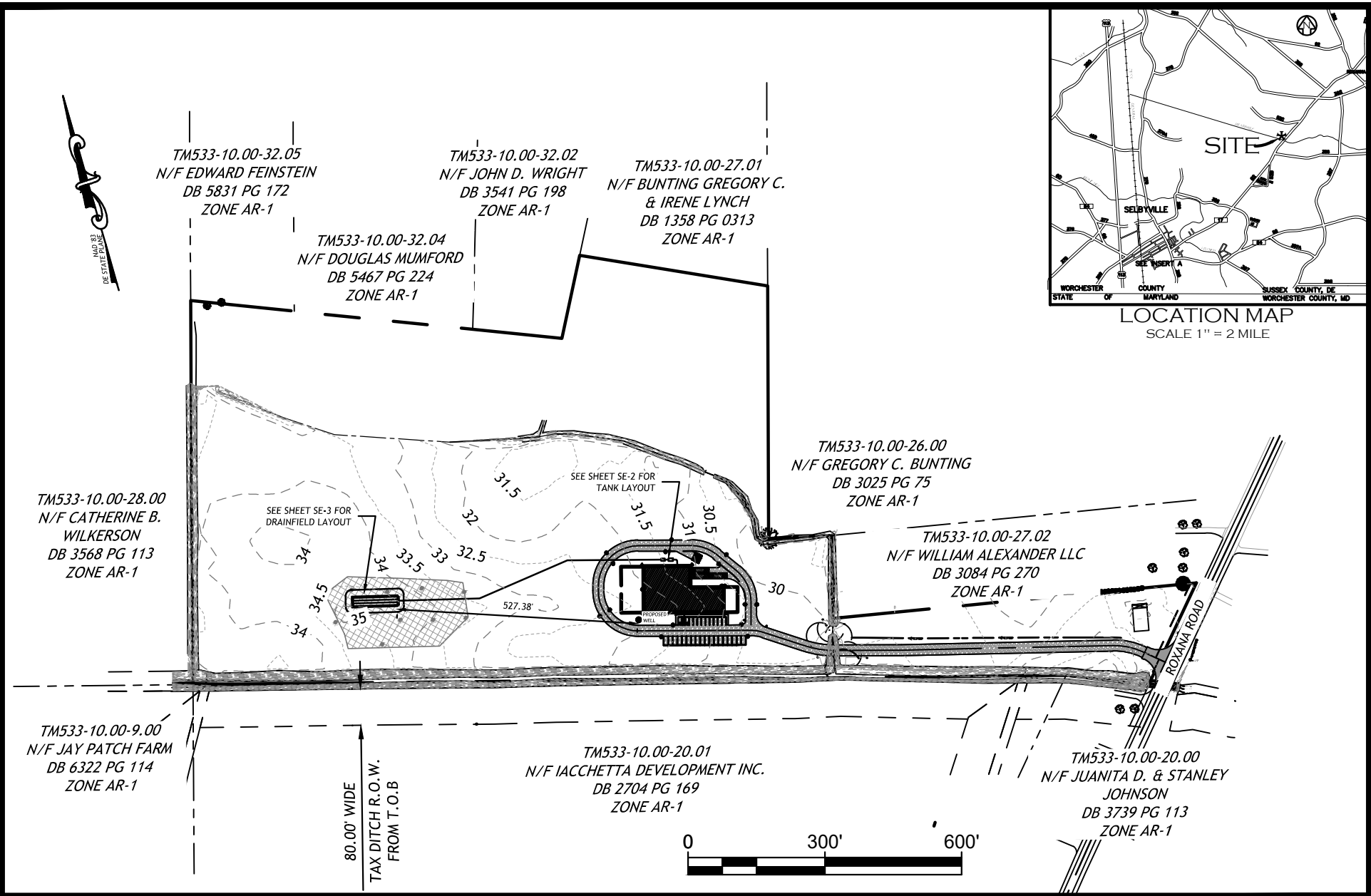

**AXIOM**  
ENGINEERING L.L.C.  
18 CHESTNUT STREET  
GEORGETOWN, DE 19947  
(302) 855-0810  
FAX: 855-0812  
E-MAIL: AXIOM@AXENG.COM  
WEB: WWW.AXENG.COM

LANDS OF WILLIAM ALEXANDER LLC  
**SITE OVERVIEW**  
BALTIMORE HUNDRED, SUSSEX COUNTY, DELAWARE

SCALE	1" = 300'	0702-2501
DESIGNED	KRC	EXHIBIT:
DRAWN	EJW	<b>SE-1</b>
CHECKED	KRC	
DATE	04/06/2026	
T.M.	533-10.00-27.00	

- ① CLEANOUT
- ② 4" BUILDING SEWER (22' LONG)
- ③ 1,500 GALLON SEPTIC TANK W/MICROFAST 0.75 UNIT
- ④ 4" SCH 40 PVC (10' LONG)
- ⑤ 1,000 GAL DOSING CHAMBER
- ⑥ 3" SCH 40 PVC TRANSMISSION LINE (592' LONG)

NOTES

1. ALL TANKS SHALL HAVE WATERTIGHT RISERS AND SHALL EXTEND ABOVE GRADE. SEPTIC TANK SHALL HAVE AN EFFLUENT FILTER APPROVED BY DNREC.
2. THE BOUNDARY AND TOPOGRAPHIC INFORMATION SHOWN ON THIS PLAT WAS TAKEN FROM A FIELD SURVEY PREPARED BY AXIOM ENGINEERING, LLC IN OCTOBER 2025.
3. CONTRACTOR SHALL HAVE DRAINFIELD STAKED FOR VERTICAL AND HORIZONTAL CONTROL BY THE PROJECT SURVEYOR AT THE OWNER'S EXPENSE TO ENSURE PROPER SEPARATION FROM THE LIMITING ZONE.
4. INSTALLATION SHALL OCCUR DURING PROPER SOIL MOISTURE CONDITIONS (SATURATION > 4 FT. BELOW GRADE), EXPERIENCED CLASS C WASTEWATER INSTALLER SHALL FOLLOW THE "SITE WORK REQUIREMENTS" OUTLINED ON SITE EVALUATION APPROVAL PAGE 1. DURING PROPER SOIL MOISTURE CONDITIONS, THE DRAINFIELD AND BERM BASAL AREAS IS TO BE CHISEL/SUBSOIL/MOLDBOARD PLOWED 8-12 INCHES BELOW GROUND SURFACE IN ACCORDANCE WITH THE REGULATIONS.
5. NO VEHICULAR TRAFFIC (NON-TRACKED OR HIGH GROUND PRESSURE) IS TO ENTER THE DRAINFIELD AREA FOR THE PURPOSES OF DUMPING ENGINEERED SANDY FILL OR FOR ANY OTHER PURPOSE. THE PROPERTY OWNERSHIP/DEVELOPER IS RESPONSIBLE FOR PLACING A SUBSTANTIAL BARRIER AROUND THE PROPOSED OWTD'S DRAINFIELD AREA PRIOR TO INSTALLATION TO PREVENT OVER-TRAFFICING OR ACCIDENTAL COMPACTION. (SEE BARRICADING GUIDELINE IN THE REGULATIONS).

MATCH TO SE-3

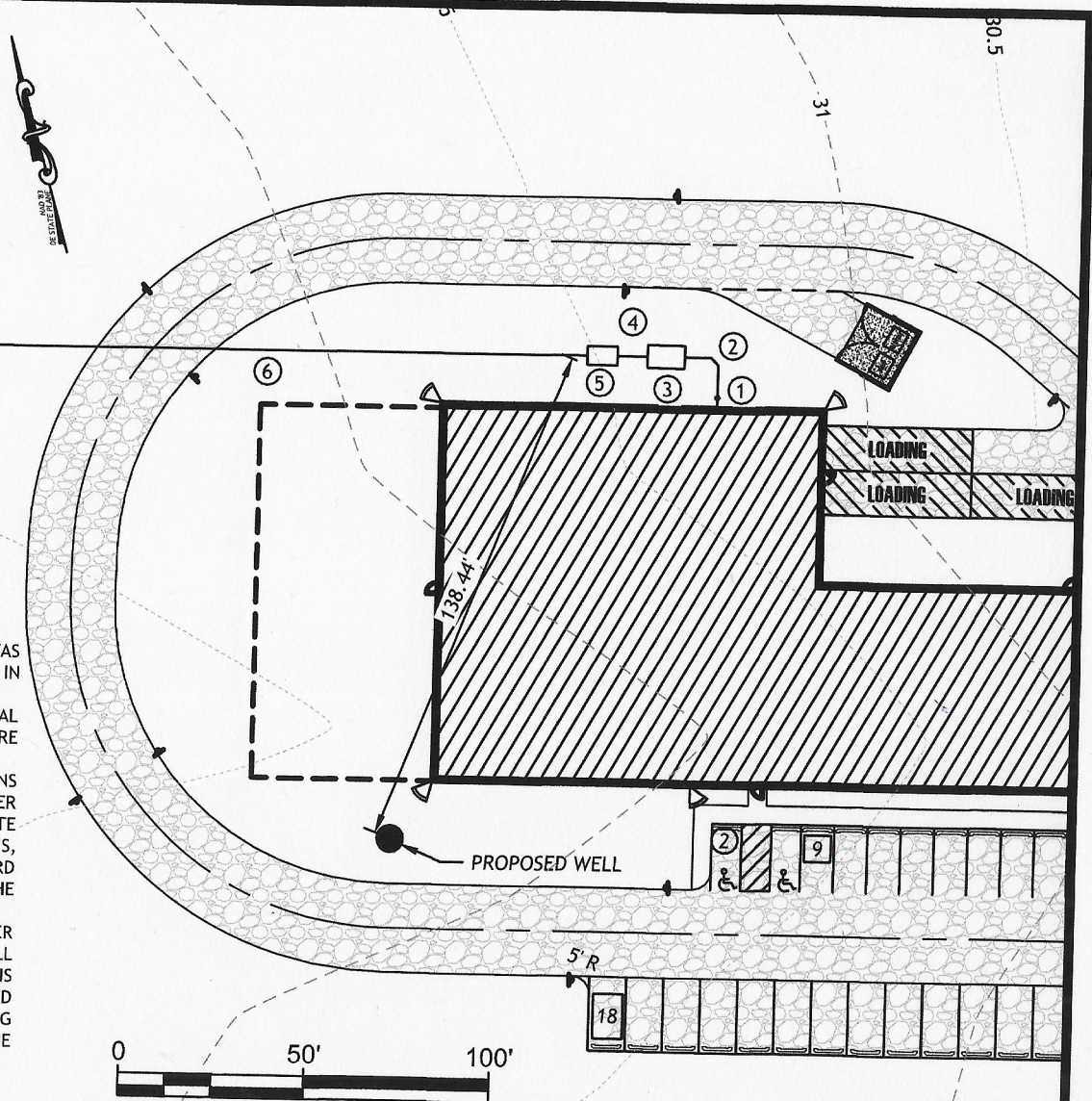

*Amy M. Caldwell*  
 AUTHORIZED AGENT/ OWNER SIGNATURE DATE 4/22/24

**AE AXIOM ENGINEERING L.L.C.**  
 18 CHESTNUT STREET  
 GEORGETOWN, DE 19947  
 (302) 855-0810  
 FAX: 855-0812  
 EMAIL: AXIOM@AXENG.COM  
 WEB: WWW.AXENG.COM

LANDS OF WILLIAM ALEXANDER LLC  
**SEPTIC PLAN**  
 BALTIMORE HUNDRED, SUSSEX COUNTY, DELAWARE

SCALE	1" = 50'	0702-2501
DESIGNED	KRC	EXHIBIT.
DRAWN	EJW	<b>SE-2</b>
CHECKED	KRC	
DATE	04/06/2026	
T.M.	533-10.00-27.00	

- ① CLEANOUT
- ② 4" BUILDING SEWER (22' LONG)
- ③ 1,500 GALLON SEPTIC TANK W/MICROFAST 0.75 UNIT
- ④ 4" SCH 40 PVC (10' LONG)
- ⑤ 1,000 GAL DOSING CHAMBER
- ⑥ 3" SCH 40 PVC TRANSMISSION LINE (592' LONG)

**NOTES**

1. ALL TANKS SHALL HAVE WATERTIGHT RISERS AND SHALL EXTEND ABOVE GRADE.
2. SEPTIC TANK SHALL HAVE AN EFFLUENT FILTER APPROVED BY DNREC.
3. THE BOUNDARY AND TOPOGRAPHIC INFORMATION SHOWN ON THIS PLAT WAS TAKEN FROM A FIELD SURVEY PREPARED BY AXIOM ENGINEERING, LLC IN OCTOBER 2025.
4. CONTRACTOR SHALL HAVE DRAINFIELD STAKED FOR VERTICAL AND HORIZONTAL CONTROL BY THE PROJECT SURVEYOR AT THE OWNER'S EXPENSE TO ENSURE PROPER SEPARATION FROM THE LIMITING ZONE.
5. INSTALLATION SHALL OCCUR DURING PROPER SOIL MOISTURE CONDITIONS (SATURATION > 4 FT. BELOW GRADE), EXPERIENCED CLASS C WASTEWATER INSTALLER SHALL FOLLOW THE "SITE WORK REQUIREMENTS" OUTLINED ON SITE EVALUATION APPROVAL PAGE 1. DURING PROPER SOIL MOISTURE CONDITIONS, THE DRAINFIELD AND BERM BASAL AREA IS TO BE CHISEL/SUBSOIL/MOLDBOARD PLOWED 8-12 INCHES BELOW GROUND SURFACE IN ACCORDANCE WITH THE REGULATIONS.
6. NO VEHICULAR TRAFFIC (NON-TRACKED OR HIGH GROUND PRESSURE) IS TO ENTER THE DRAINFIELD AREA FOR THE PURPOSES OF DUMPING ENGINEERED SANDY FILL OR FOR ANY OTHER PURPOSE. THE PROPERTY OWNERSHIP/DEVELOPER IS RESPONSIBLE FOR PLACING A SUBSTANTIAL BARRIER AROUND THE PROPOSED OWTDS DRAINFIELD AREA PRIOR TO INSTALLATION TO PREVENT OVER-TRAFFICING OR ACCIDENTAL COMPACTION. (SEE BARRICADING GUIDELINE IN THE REGULATIONS).

MATCH TO SE-3

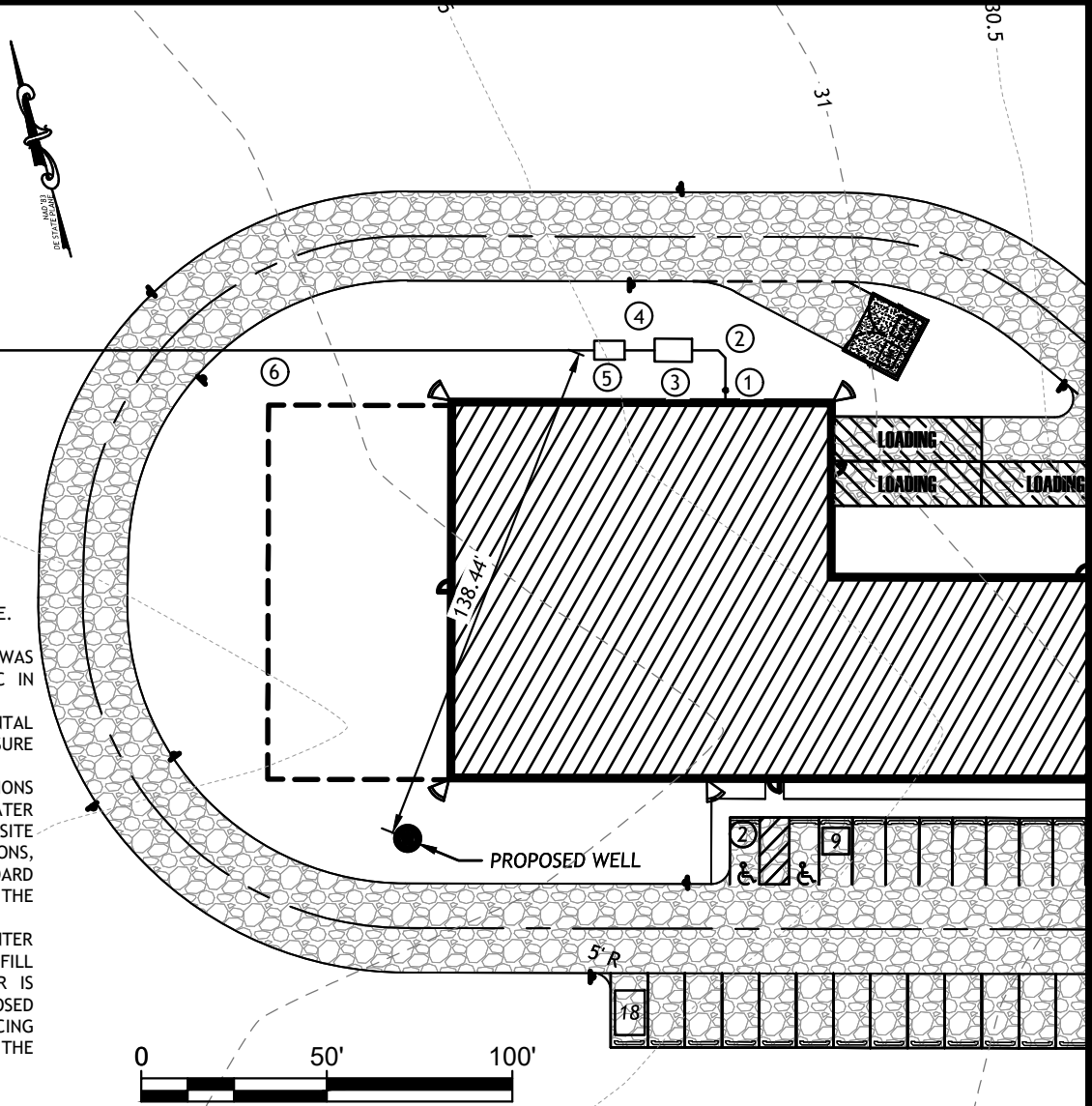

\_\_\_\_\_  
 AUTHORIZED AGENT/ OWNER SIGNATURE      DATE

**AE AXIOM**  
 ENGINEERING L.L.C.  
 18 CHESTNUT STREET  
 GEORGETOWN, DE 19947  
 (302) 855-0810  
 FAX: 855-0812  
 E-MAIL: AXIOM@AXENG.COM  
 WEB: WWW.AXENG.COM

LANDS OF WILLIAM ALEXANDER LLC  
**SEPTIC PLAN**  
 BALTIMORE HUNDRED, SUSSEX COUNTY, DELAWARE

SCALE	1" = 50'
DESIGNED	KRC
DRAWN	EJW
CHECKED	KRC
DATE	04/06/2026
T.M.	533-10.00-27.00

0702-2501  
 EXHIBIT:  
**SE-2**

**NOTES**

1. SEE NOTES ON SHEET SE-2 REGARDING CONSTRUCTION OF DRAINFIELD
2. SEE EROSION CONTROL PLAN ESC-3 FOR PLACEMENT OF ORANGE SAFETY FENCE AROUND PERIMETER OF ON-SITE WASTEWATER DISPOSAL DRAINFIELD AREA.

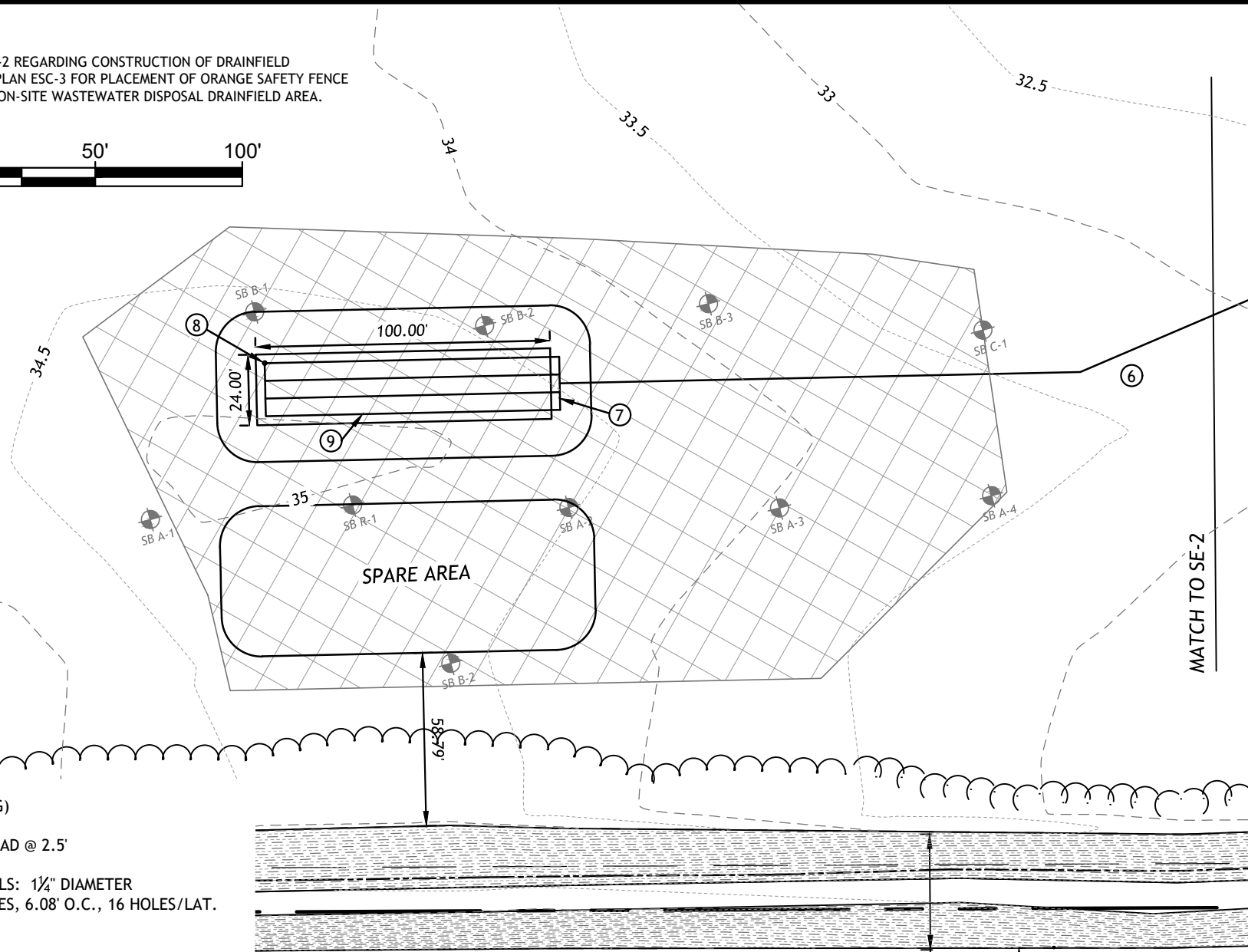
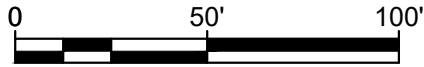

- ⑦ 2" MANIFOLD (18' LONG)
- ⑧ TURN UP TYP., SET HEAD @ 2.5'
- ⑨ 4 SCH. 40 PVC LATERALS: 1¼" DIAMETER  
100' LONG, 3/16" HOLES, 6.08' O.C., 16 HOLES/LAT.

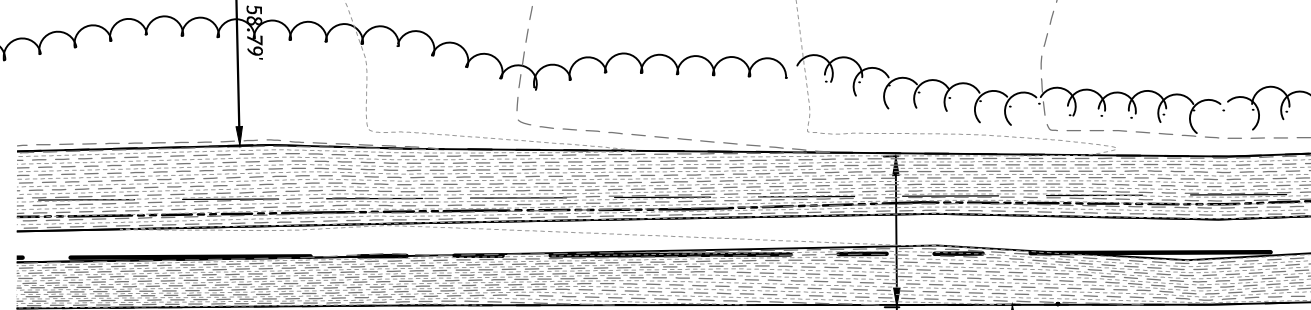

**AXIOM**  
ENGINEERING L.L.C.  
18 CHESTNUT STREET  
GEORGETOWN, DE 19947  
(302) 855-0810  
FAX: 855-0812  
E-MAIL: AXIOM@AXENG.COM  
WEB: WWW.AXENG.COM

LANDS OF WILLIAM ALEXANDER LLC  
**SEPTIC PLAN**  
BALTIMORE HUNDRED, SUSSEX COUNTY, DELAWARE

SCALE	1" = 50'	0702-2501
DESIGNED	KRC	EXHIBIT:
DRAWN	EJW	<b>SE-3</b>
CHECKED	KRC	
DATE	04/06/2026	
T.M.	533-10.00-27.00	

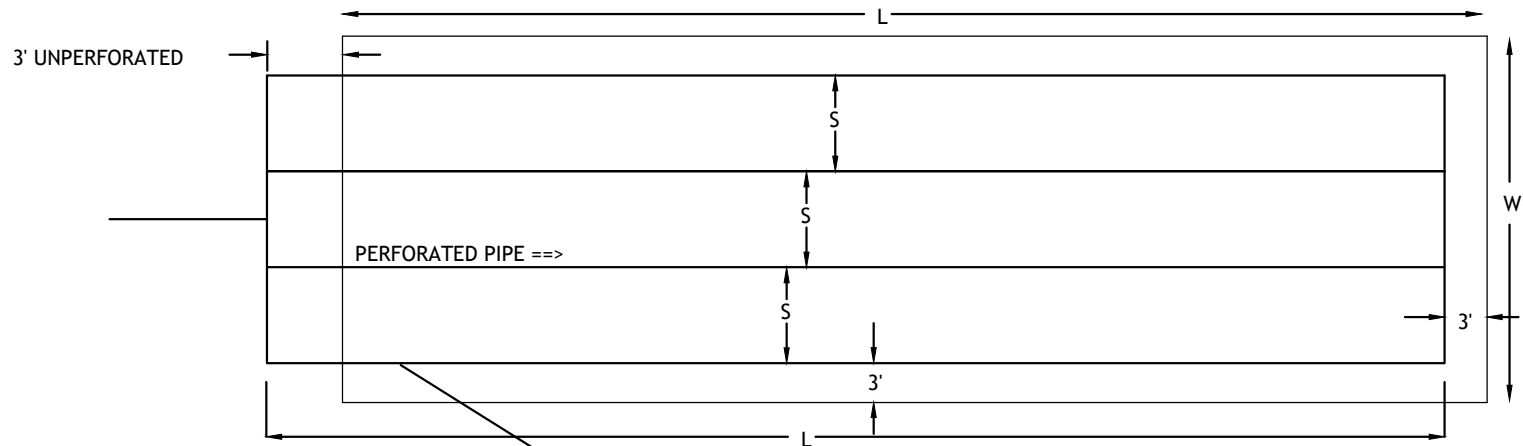

$24' = W =$  DISPOSAL AREA WIDTH (25' MAX.)  
 $100' = L =$  DISPOSAL AREA LENGTH (100' MAX.)  
 $4 = N =$  NUMBER OF LATERALS  
 $6' = S =$  LATERAL SPACING (4'-6')  
 $15'' - 27'' = H =$  HEIGHT OF SANDY FILL

DRILL FIRST HOLE  $3' + \frac{1}{2}$  THE HOLE SPACING  
 LENGTH FROM MANIFOLD

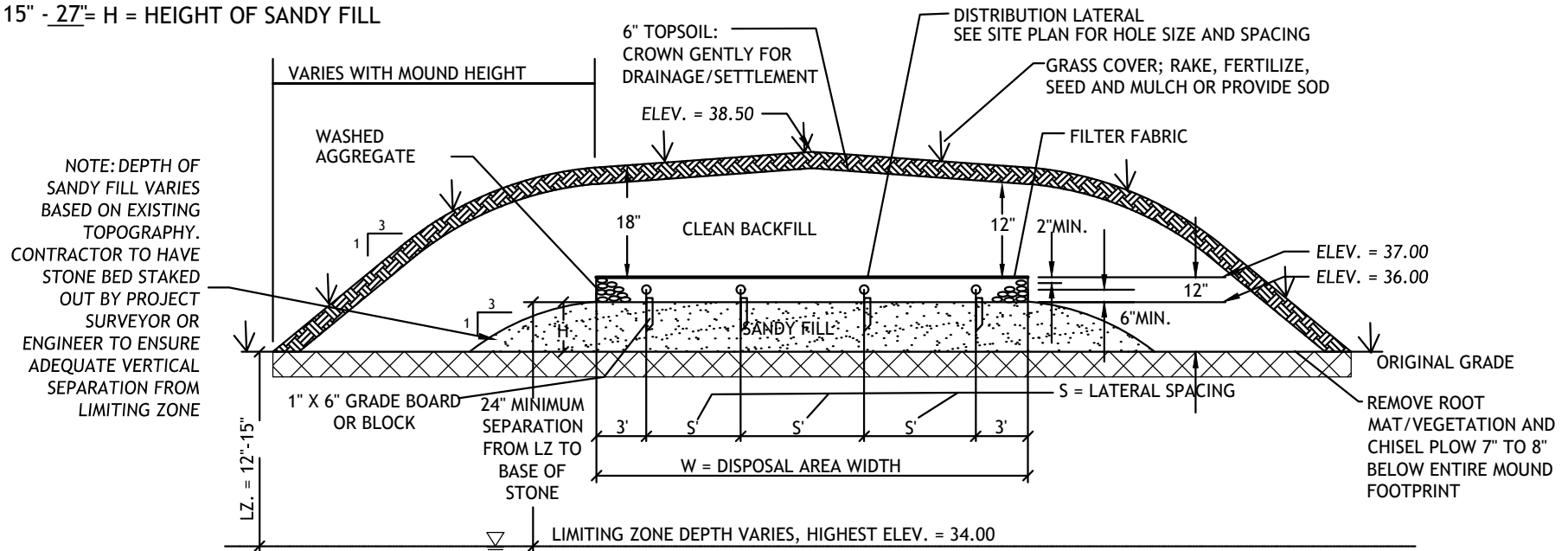

**AXIOM**  
 ENGINEERING L.L.C.  
 18 CHESTNUT STREET  
 GEORGETOWN, DE 19947  
 (302) 855-0810  
 FAX: 855-0812  
 EMAIL: AXIOM@AXENG.COM  
 WEB: WWW.AXENG.COM

LANDS OF WILLIAM ALEXANDER LLC  
**ELEVATED SAND MOUND DETAIL**  
 BALTIMORE HUNDRED, SUSSEX COUNTY, DELAWARE

SCALE	
DESIGNED	KRC
DRAWN	EJW
CHECKED	KRC
DATE	04/06/2026
T.M.	533-10.00-27.00

0702-2501  
 EXHIBIT:  
**SE-4**

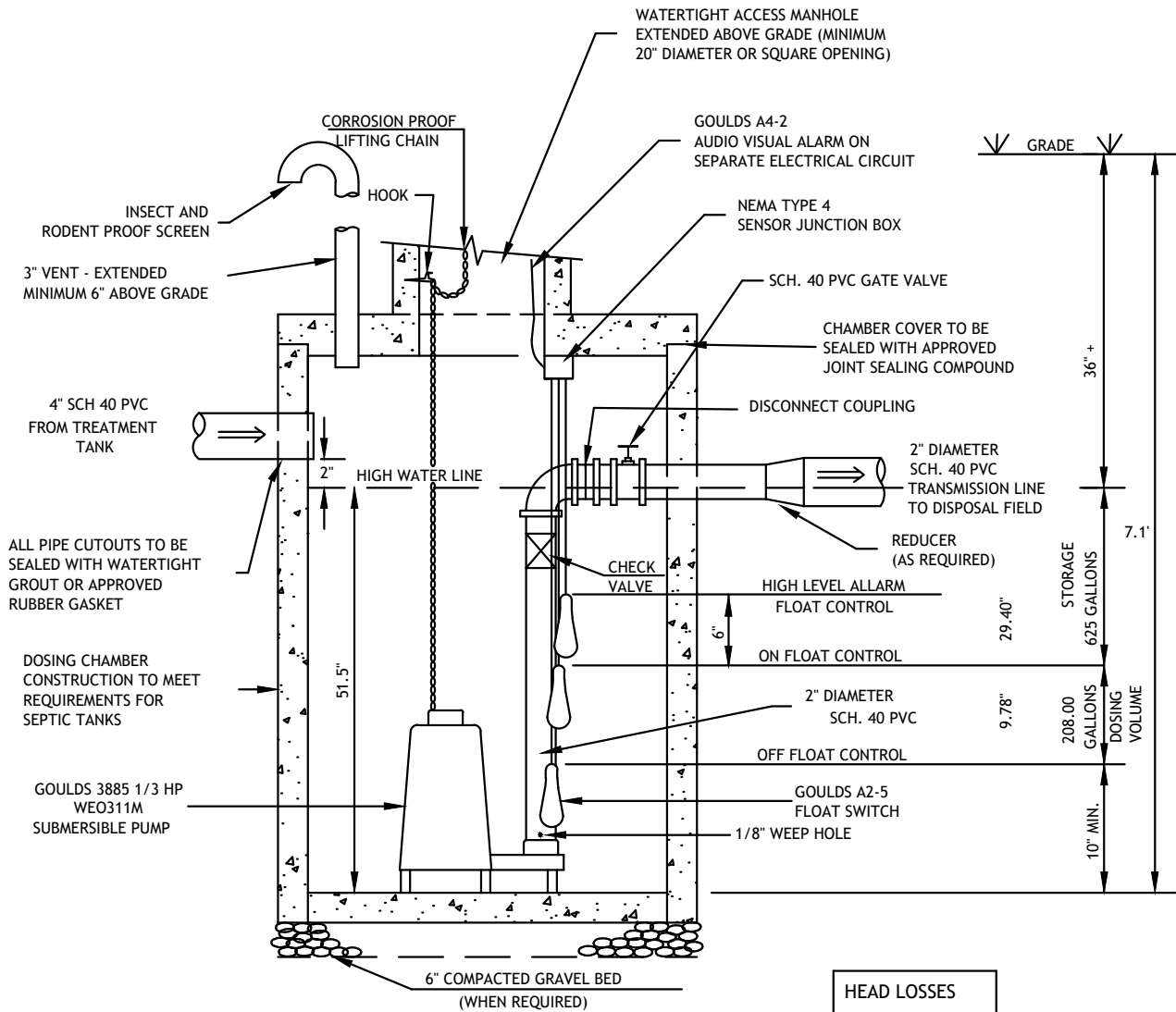

**1000 GAL DOSING CHAMBER**  
(W) 4.5' x (L) 8.17' x (D) 5.5'  
**SECTION**

**HEAD LOSSES**

STATIC	=	12.27'
ORIFICE	=	2.5'
FRICTION	=	37.00'
<b>TOTAL HEAD LOSS</b>	=	<b>51.77'</b>
		@ 43 GPM

**NOTES:**

- \* MAXIMUM DEPTH FROM GRADE TO INVERT OF DOSING CHAMBER TO BE 7'-6" UNLESS A TRAFFIC RATED TANK IS PROVIDED
- \* EXCAVATION LIMITS SHALL EXTEND AT LEAST 2 FEET BEYOND TANK PERIMETER
- \* ALL PIPE TO BE PVC SCHEDULE 40 OR SDR 26
- \* CHAMBER TO BE SIZED ACCORDING TO REQUIREMENTS OF DOSING VOLUME AND STORAGE. SEE EXHIBIT
- \* ALL DOSING CHAMBER COMPONENTS SHALL BE FIELD TESTED TO INSURE ACCURACY, WATERTIGHTNESS AND PROPER OPERATION OF ALL PUMPS AND ALARM CONTROLS
- \* ALL ELECTRICAL CONNECTIONS SHALL BE WATERPROOF, CORROSION RESISTANT AND EXPLOSION PROOF



**AXIOM**  
ENGINEERING L.L.C.  
18 CHESTNUT STREET  
GEORGETOWN, DE 19947  
(302) 855-0810  
FAX: 855-0812  
EMAIL: AXIOM@AXENG.COM  
WEB: WWW.AXENG.COM

LANDS OF WILLIAM ALEXANDER LLC  
**1,000 GAL DOSING  
CHAMBER DETAIL**  
BALTIMORE HUNDRED, SUSSEX COUNTY, DELAWARE

SCALE	
DESIGNED	KRC
DRAWN	EJW
CHECKED	KRC
DATE	04/06/2026
T.M.	533-10.00-27.00

0702-2501  
EXHIBIT  
**SE-5**

# Axiom Engineering, LLC

Application

Site Plan (CAD sheet 2)

Cross Section Detail (CAD sheet 3)

Pump Detail (CAD sheet 4) & Pump curve .pdf

SEPTIC CALCULATIONS

Rythm & Roots 4

**Job #:** 0702-2501

**Calc'd by:** K. CHRISTENBURY

**Date:** 03/19/26

Septic Timer Note

<b>Flow per Employee</b>	25	gpd
<b>Employees</b>	<u>25</u>	
<b>Daily Flow</b>	625	gpd
<b>Design flow:</b>	625	<i>gpd w/ 25% reduction for low flow devices</i>
<b>LZ = Depth to Limiting Zone:</b>	<u>12</u>	<i>in.</i>
<b>Perc. rate:</b>	<u>80</u>	<i>mpi</i>
<b>Minimum Sq. Ft. Required:</b>	2348	<i>sq. ft. for ESM system</i>
<b>Septic width:</b>	<u>24</u>	<i>ft. (Use increments of 5' based on lateral spacing of 5')</i>
<b>Septic length:</b>	<u>100</u>	<i>ft. (4x width or longer recommended)</i>
<b>Lateral Spacing:</b>	6	<i>ft (4' to 6')</i>
<b>Sq. Ft. Proposed:</b>	2400	<i>ft.^2</i>

**Type of System:** Elevated Sand Mound

**Outer Boundary:** 3 *ft.(use 3' for all ESM systems)*

**Orifice Head:** 2.5 *ft. (2.31 min.)*

## Laterals:

<b>No. of laterals:</b>	4
<b>Length of laterals:</b>	97 <i>ft. (100' max.)</i>
<b>Length O.C./hole:</b>	<u>6.08</u> <i>ft.(page 59 in regs.)</i>
<b>No. of holes/lateral:</b>	15.95395
<b>No. holes/lat. used:</b>	16
<b>Size of flow hole</b>	<u>5/16"</u>
<b>Flow/hole:</b>	<u>0.66</u> <i>gpm/hole</i>
<b>Lateral flow:</b>	10.56 <i>gpm/lateral</i>

**Total flow in field:** 42.24 *gpm*

**Total flow used:** 43 *gpm*

**Height of lateral above ground** 30 *in.*

**Height of Mound:** 54 *in.*

**Height of Sandy Fill below sto.** 24 *in.*

**Side Slope** 3 :1

**Lateral offset to disposal area:** 3 *ft.*

<b>Offset to toe of mound:</b>	-13.5 ft. from disposal area to toe (if ex. grade is flat)
<b>Static Head:</b>	9.95 ft.

**Friction Head:**

<b>Lateral Diameter:</b>	1.25 in.
<b>Lateral Flow:</b>	10.56 gpm/lateral
<b>Head loss/100 ft.:</b>	3.39 ft./100 ft.
<b>Length of Lateral:</b>	97 ft.
<b>Multiplier for fittings:</b>	1.2
<b>Lateral head loss:</b>	3.95 ft.

<b>Manifold Diameter:</b>	2 in.
<b>Manifold Flow:</b>	21.5 gpm / half manifold
<b>Head loss/100 ft.:</b>	1.28 ft./100 ft.
<b>Manifold Length</b>	18.00 ft.
<b>1/2 Length of manifold:</b>	9 ft.
<b>Multiplier for fittings:</b>	1.2
<b>Manifold head loss:</b>	0.14 ft.

<b>Trans. line diameter:</b>	2 in.
<b>Trans. Line flow</b>	43 gpm
<b>Head loss/100 ft.:</b>	4.63 ft./100 ft.
<b>Length of trans. line:</b>	593 ft.
<b>Multiplier for fittings:</b>	1.2
<b>Trans. line head loss:</b>	32.92 ft.

**Total friction head:** 37.00 ft.

<b>TDH:</b>	49.45 ft.
<b>Total flow used:</b>	43 gpm

**Check dosing volume:**

**Lateral diameter:** 1.25 *in.*  
**Volume/ft. of lateral:** 0.06 *gal/ft.*  
**Linear feet of lateral:** 424 *ft.*  
**Lateral volume:** 27.03 *gal.*

**Manifold diameter:** 2 *in.*  
**Volume/ft. of lateral:** 0.16 *gal/ft.*  
**Linear feet of manifold:** 18 *ft.*  
**Manifold volume:** 2.9373891 *gal.*

**Trans. line diameter:** 2 *in.*  
**Volume/ft. of trans. line:** 0.16 *gal/ft.*  
**Linear feet of trans. line:** 593 *ft.*  
**Trans. line volume:** 96.770653 *gal.*

**Min. dosing volume:** 135.1403 *gal.*  
**Dosing vol. used:** 208 *gal.*

**Doses per day (min. 2):** 3.00

Dosing Tank Minimum Size (1 day + 1 dose ) = 833 *gal.*

**Size of dosing chamber:** 1000 *gal.*

**Volume/in. of chamber:** 15.60 *gal/in.*  
**Height of storage above dose:** 40.06 *in.*  
**Set dosing float at:** 13.33 *in.*

**Set timer run time at:** 4.84 *min.*  
 290 *seconds*

**Set hours off at:** 8 *hours*

Tank Height 36 *inch bury*

Storage	625 gallons	40.06	inch height above dose
Dose	208 gallons	13.33	inch dose
		10.00	inch wet volume
		99.40	inch tank depth
		8.3	ft. tank depth

REVISIONS		
REV.	DESCRIPTION	DATE
E	RELEASED TO CURRENT	6/24/2022

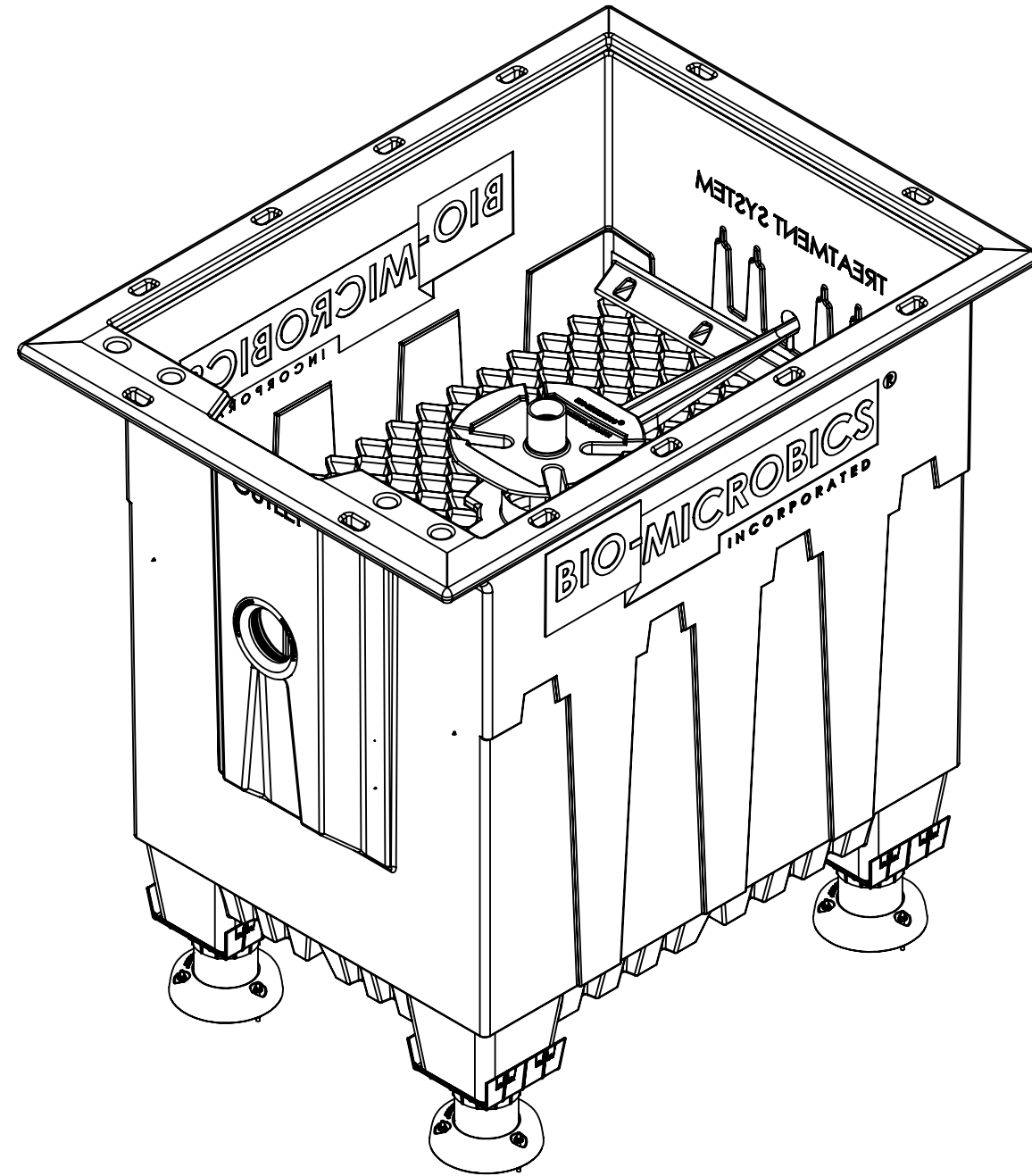

**MicroFAST® 0.75 WITH FEET**

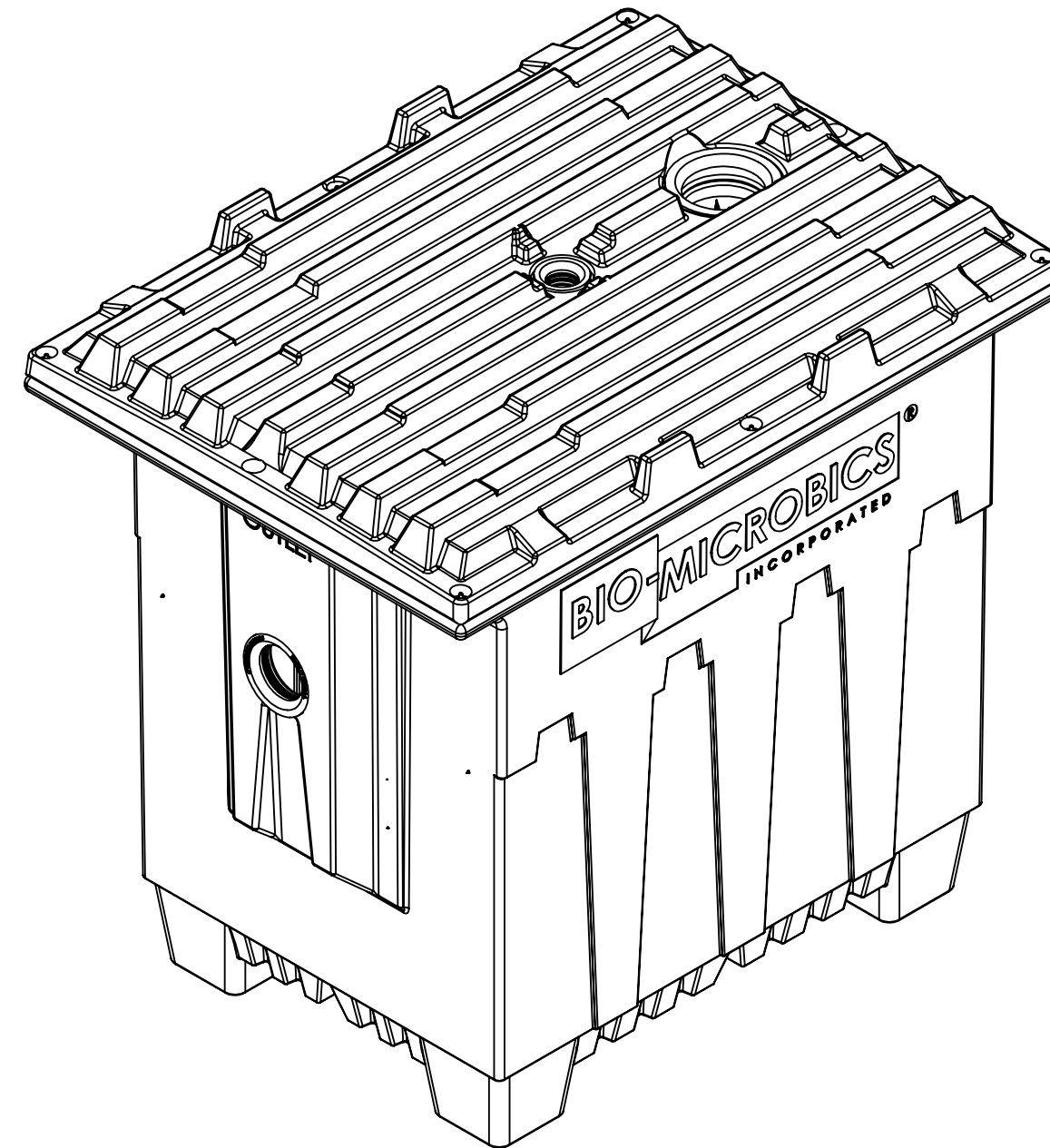

**MicroFAST® 0.75 WITH LID**

<b>PROPRIETARY AND CONFIDENTIAL</b>		UNLESS OTHERWISE SPECIFIED DIMENSIONS ARE IN INCHES AND TOLERANCES ARE AS FOLLOWS X° ± 1° .X ± .50 .XX ± .25	 BETTER WATER. BETTER WORLD.
THE INFORMATION CONTAINED IN THIS DRAWING IS THE SOLE PROPERTY OF BIOMICROBICS, INC.. ANY REPRODUCTION IN PART OR AS A WHOLE WITHOUT THE WRITTEN PERMISSION OF BIOMICROBICS, INC. IS PROHIBITED.			
<b>DO NOT SCALE DRAWING</b>		DRAWN BY: ESG	DESCRIPTION MICROFAST 0.75 UNIT VIEWS
SHEET 1 OF 6		DATE: 6/24/2022	PART NUMBER 600-FINMCF0.75
SCALE: N/A	SIZE: B	APPROVED BY: MSH	REV E
		APPROVED DATE: 6/24/2022	

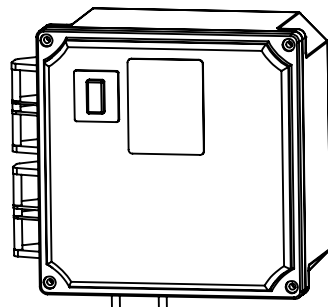
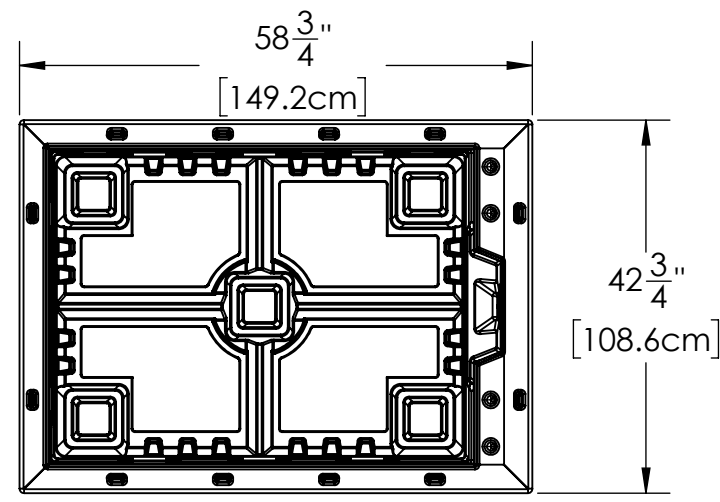
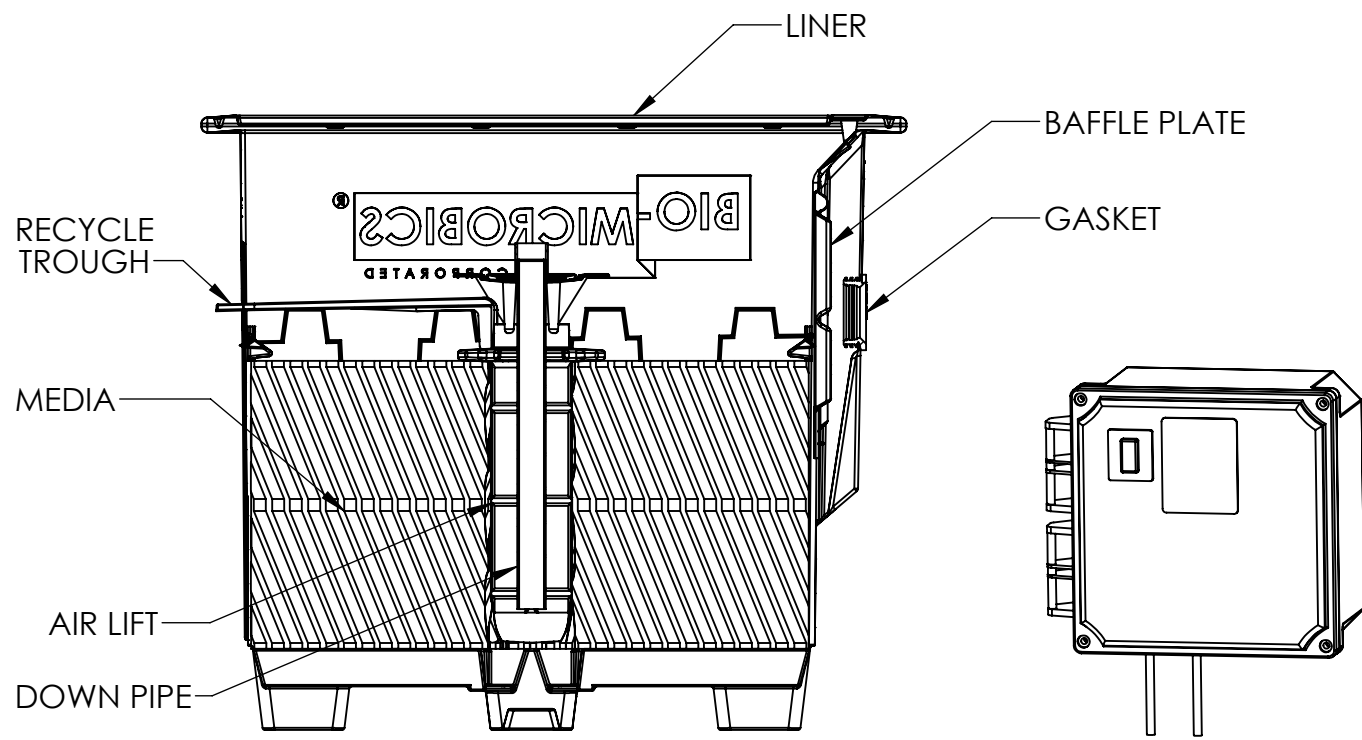

**CONTROL PANEL**

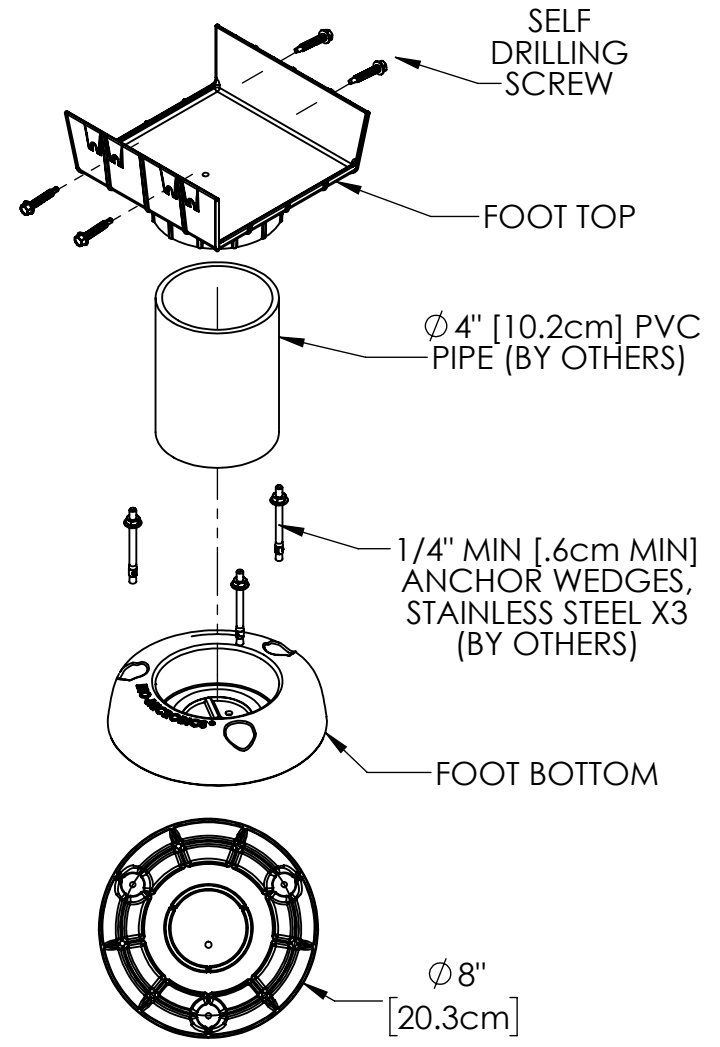
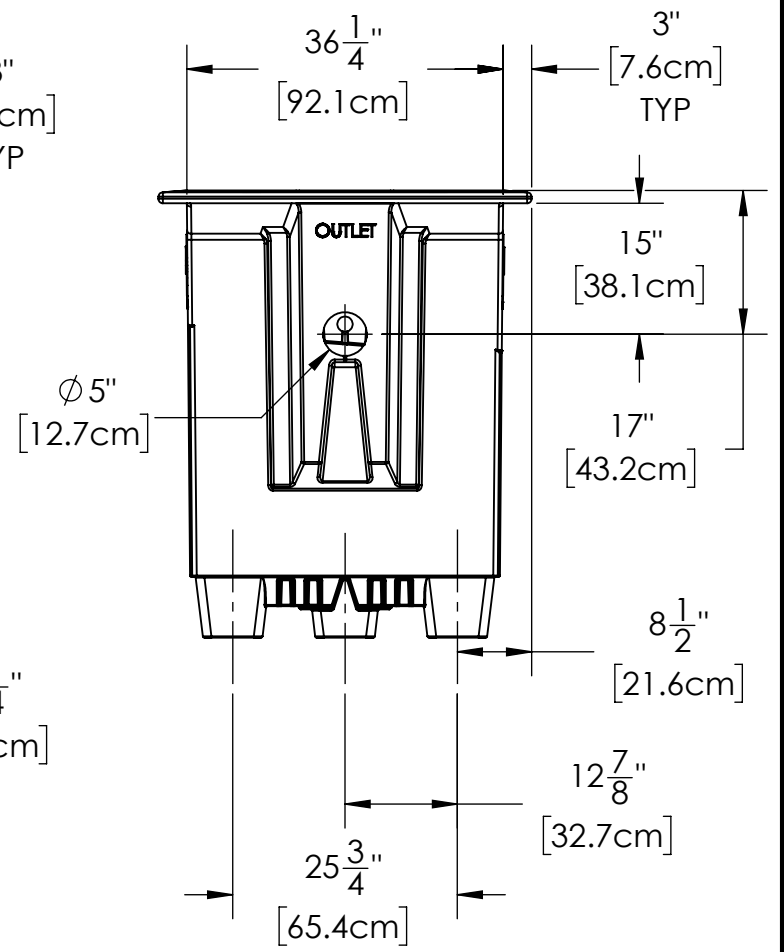
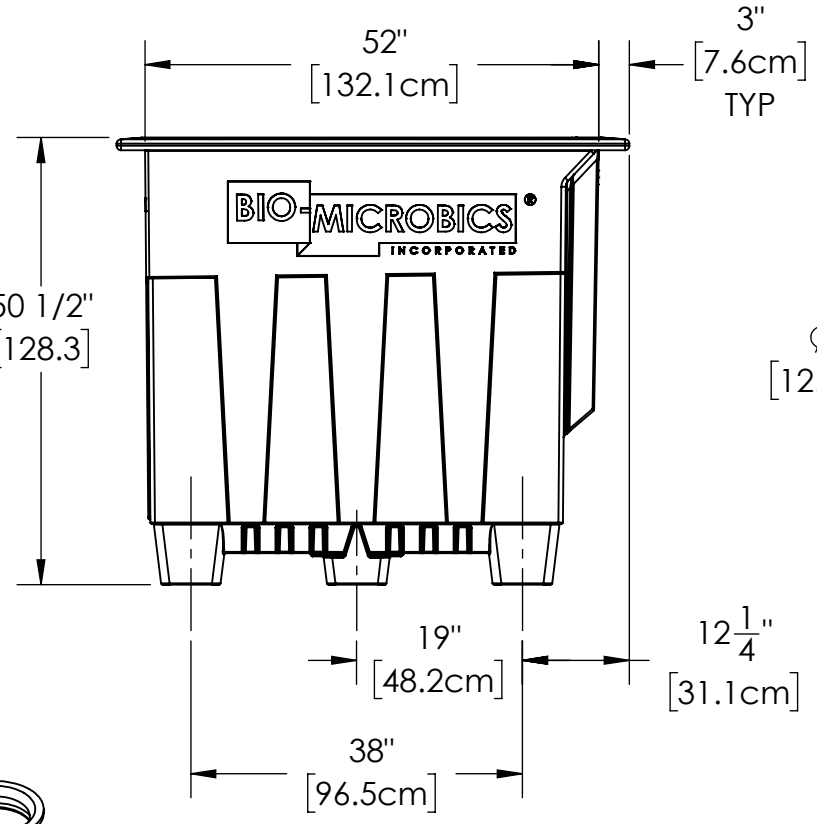

**OPTIONAL FEET**

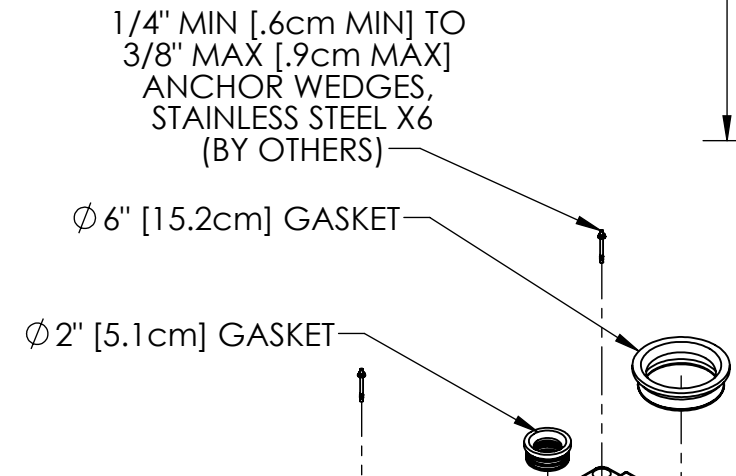

**OPTIONAL LID**

**NOTES:**  
1. ITEMS ARE DEPICTIONS AND MAY VARY IN APPEARANCE.

<b>PROPRIETARY AND CONFIDENTIAL</b>		UNLESS OTHERWISE SPECIFIED DIMENSIONS ARE IN INCHES AND TOLERANCES ARE AS FOLLOWS		
THE INFORMATION CONTAINED IN THIS DRAWING IS THE SOLE PROPERTY OF BIOMICROBICS, INC.. ANY REPRODUCTION IN PART OR AS A WHOLE WITHOUT THE WRITTEN PERMISSION OF BIOMICROBICS, INC. IS PROHIBITED.		X° ± 1° .X ± .50 .XX ± .25		
<b>DO NOT SCALE DRAWING</b>		DRAWN BY: ESG		DESCRIPTION <b>MICROFAST 0.75 UNIT DETAILS</b>
		DATE: 6/24/2022		
SHEET 2 OF 6		APPROVED BY: MSH		PART NUMBER
SCALE: N/A	SIZE: B	APPROVED DATE: 6/24/2022		600-FINMCF0.75
				REV E

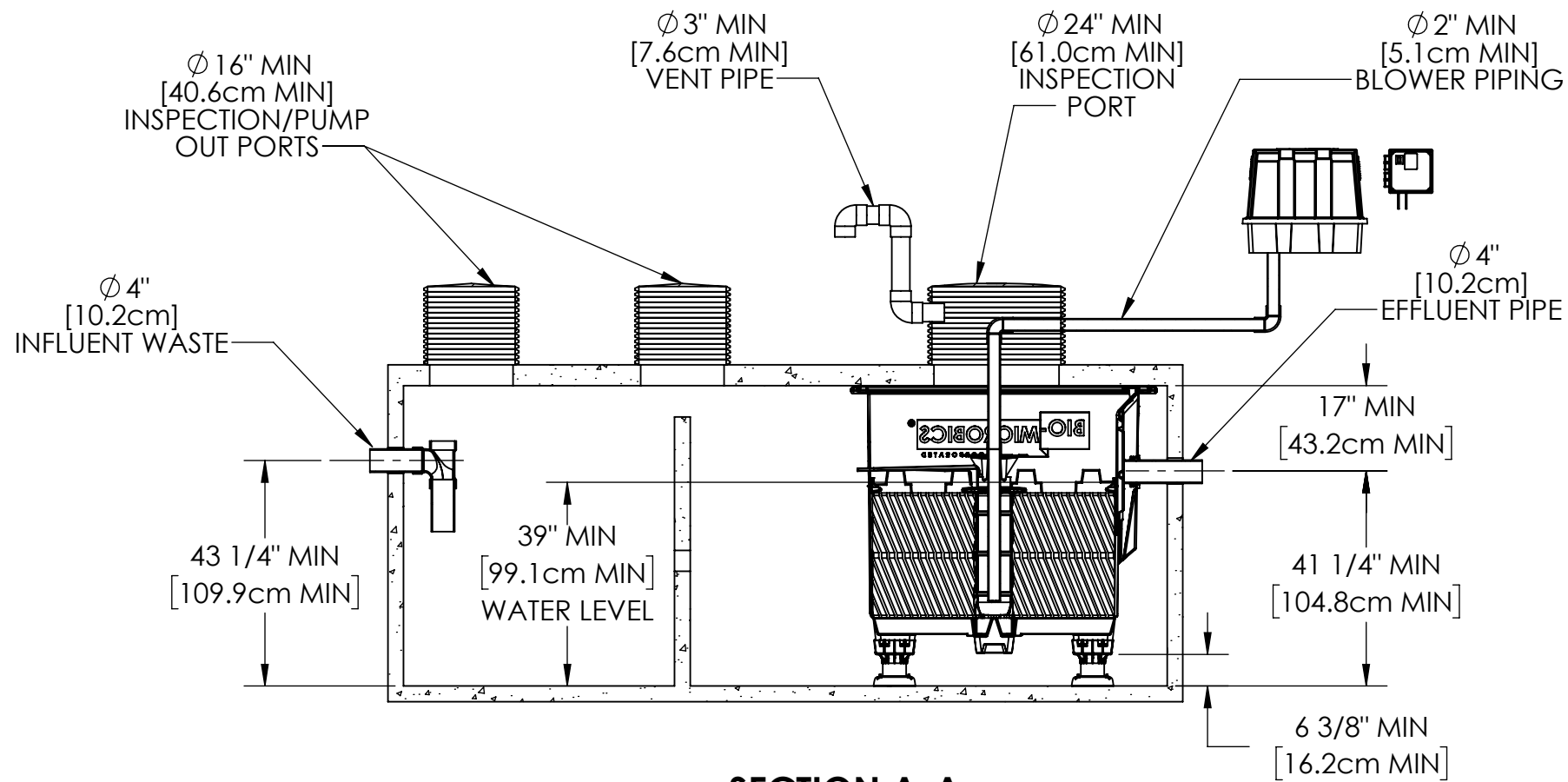

**SECTION A-A**

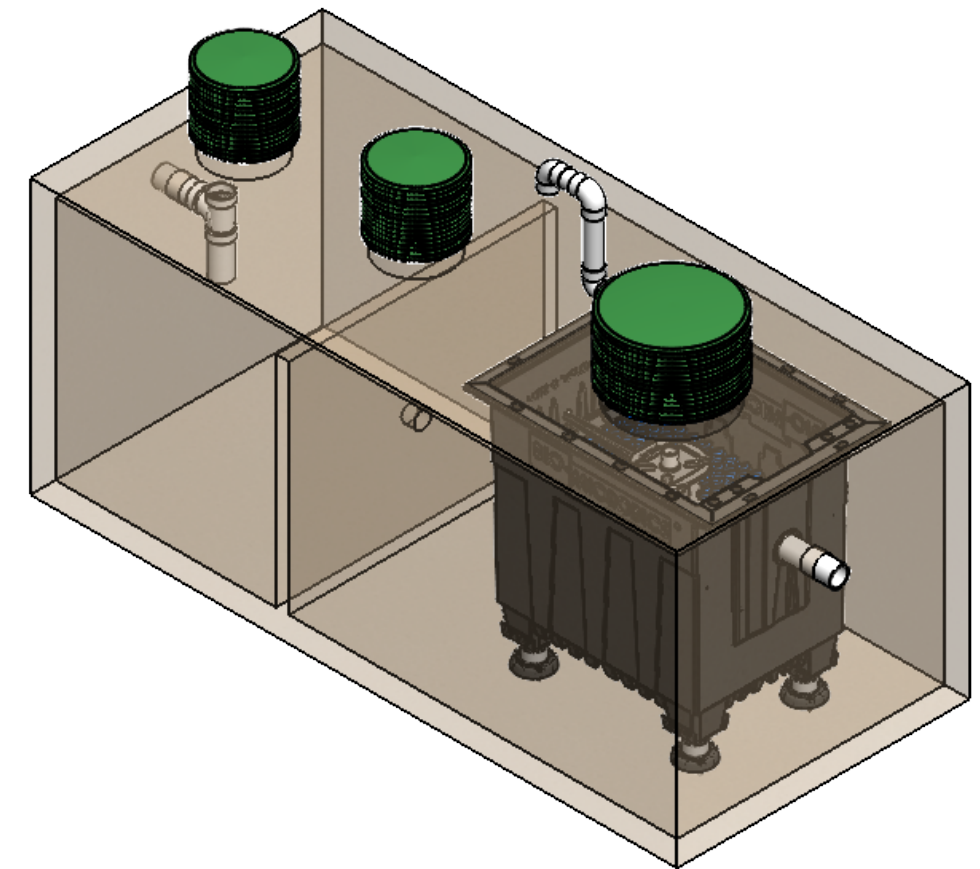
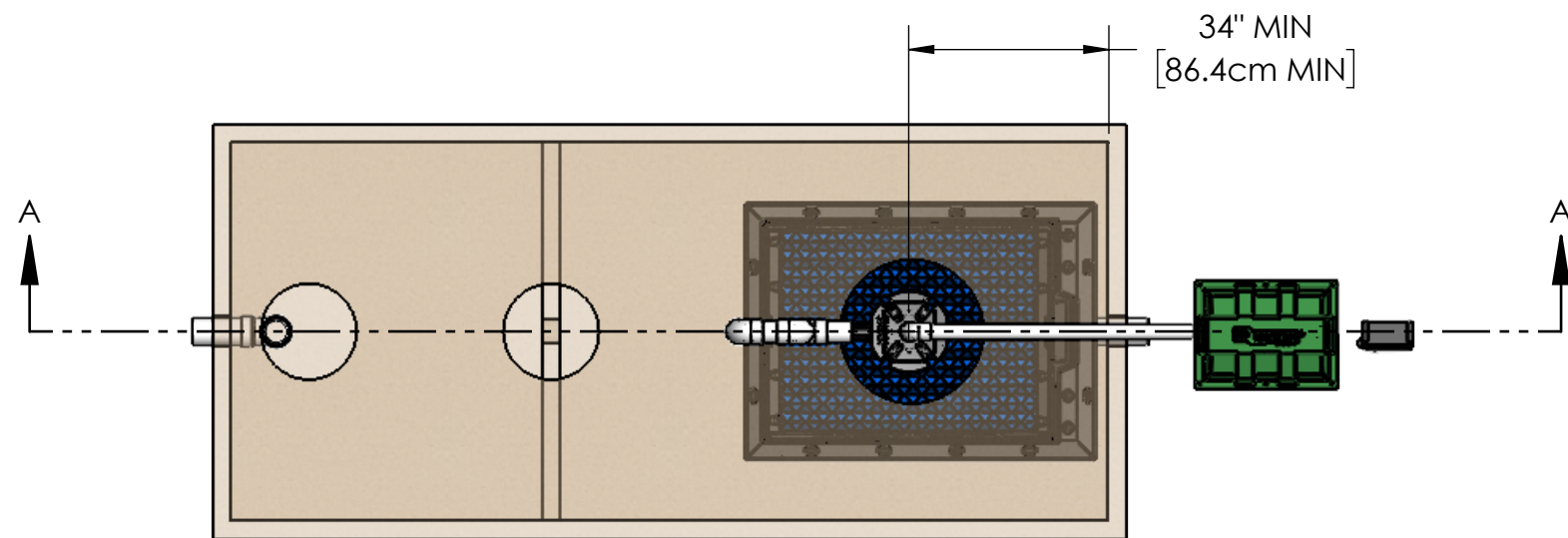

**NOTES:**

1. AIRLINE PIPING TO FAST® SHOULD NOT EXCEED 100 FT (30M) TOTAL LENGTH AND SHOULD HAVE A MAXIMUM OF 4 ELBOWS IN THE PIPING SYSTEM. FOR DISTANCES GREATER THAN 100 FT (30M) CONSULT FACTORY.
2. IF LESS THAN THE SPECIFIED MINIMUMS ARE CONSIDERED NECESSARY, CONSULT FACTORY FOR GUIDANCE.
3. SPECIALIZED TREATMENT NEEDS MAY REQUIRE SPECIFIC FEATURES TO BE INCORPORATED INTO THE DESIGN. CONSULT FACTORY FOR GUIDANCE.
4. SOME ITEMS REMOVED FOR CLARITY.
5. MINIMUM OF 2.0in [5.1cm] INVERT IS NECESSARY BETWEEN THE INLET AND OUTLET OF EACH ZONE FOR GRAVITY FLOW SYSTEMS.

<p><b>PROPRIETARY AND CONFIDENTIAL</b></p> <p>THE INFORMATION CONTAINED IN THIS DRAWING IS THE SOLE PROPERTY OF BIOMICROBICS, INC.. ANY REPRODUCTION IN PART OR AS A WHOLE WITHOUT THE WRITTEN PERMISSION OF BIOMICROBICS, INC. IS PROHIBITED.</p> <p><b>DO NOT SCALE DRAWING</b></p>		<p>UNLESS OTHERWISE SPECIFIED DIMENSIONS ARE IN INCHES AND TOLERANCES ARE AS FOLLOWS</p> <p>X° ± 1°  X ± .50  XX ± .25</p>	 <p>BETTER WATER. BETTER WORLD.</p>	
<p>SHEET 3 OF 6</p>		<p>DRAWN BY: ESG</p> <p>DATE: 6/24/2022</p>	<p>DESCRIPTION MICROFAST 0.75 UNIT WITH FEET</p>	
<p>SCALE: 1:32</p>	<p>SIZE: B</p>	<p>APPROVED BY: MSH</p> <p>APPROVED DATE: 6/24/2022</p>	<p>PART NUMBER 600-FINMCF0.75</p>	<p>REV E</p>

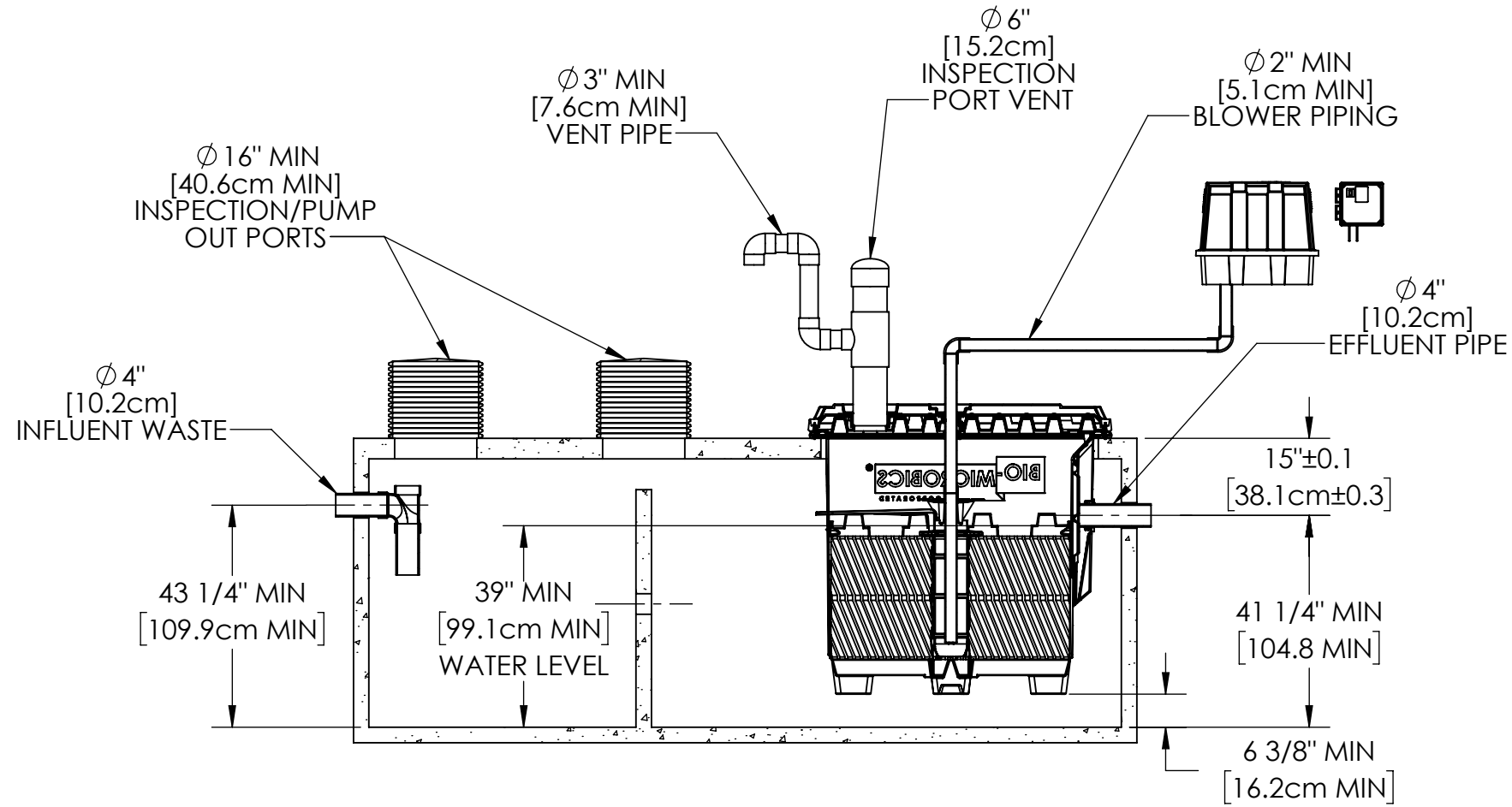

**SECTION B-B**

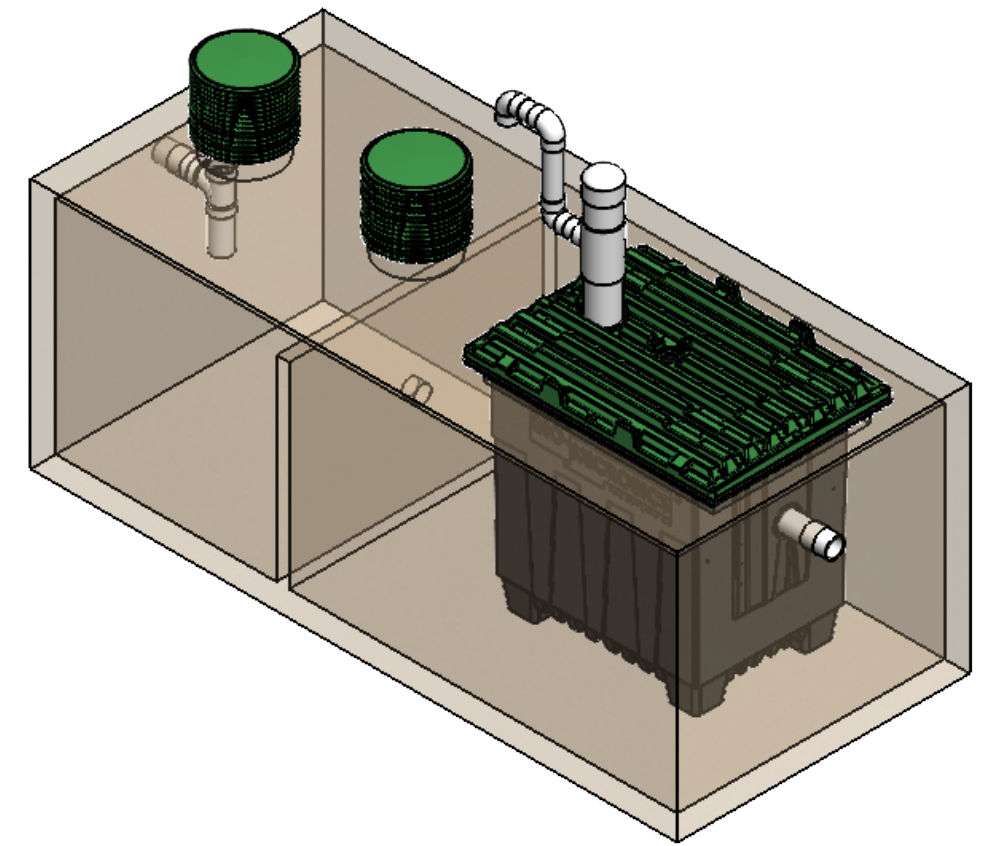
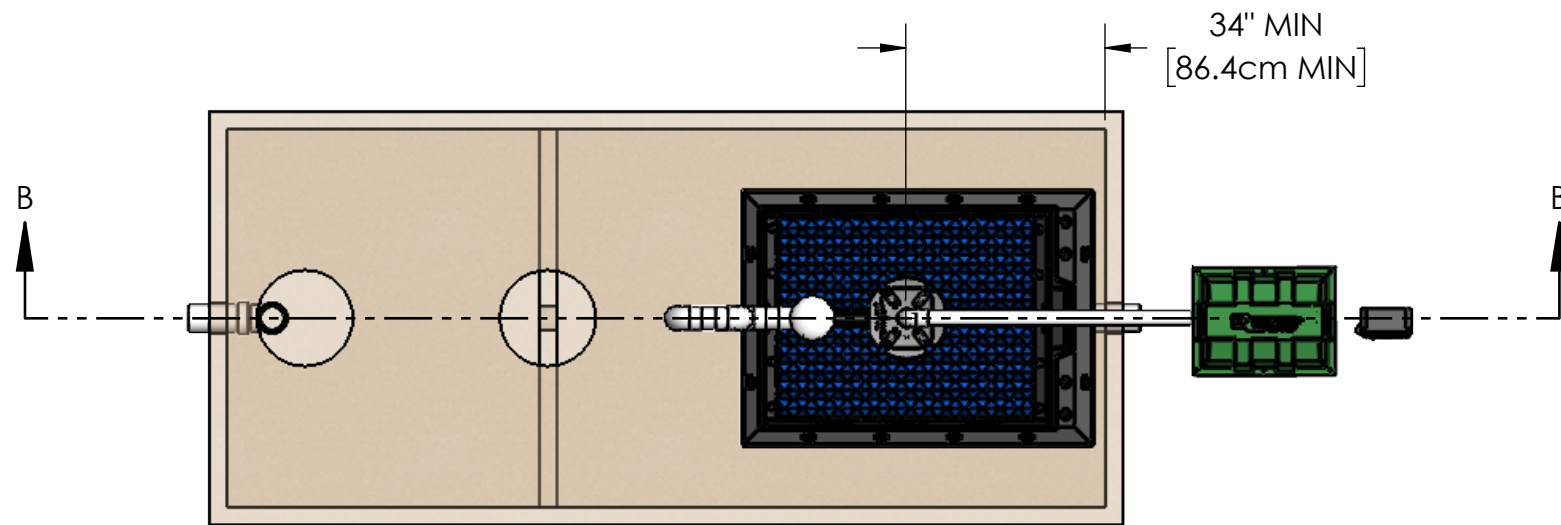

**NOTES:**

1. AIRLINE PIPING TO FAST@ SHOULD NOT EXCEED 100 FT (30M) TOTAL LENGTH AND SHOULD HAVE A MAXIMUM OF 4 ELBOWS IN THE PIPING SYSTEM. FOR DISTANCES GREATER THAN 100 FT (30M) CONSULT FACTORY.
2. IF LESS THAN THE SPECIFIED MINIMUMS ARE CONSIDERED NECESSARY, CONSULT FACTORY FOR GUIDANCE.
3. SPECIALIZED TREATMENT NEEDS MAY REQUIRE SPECIFIC FEATURES TO BE INCORPORATED INTO THE DESIGN. CONSULT FACTORY FOR GUIDANCE.
4. SOME ITEMS REMOVED FOR CLARITY.
5. MINIMUM OF 2.0in [5.1 cm] INVERT IS NECESSARY BETWEEN THE INLET AND OUTLET OF EACH ZONE FOR GRAVITY FLOW SYSTEMS.

<b>PROPRIETARY AND CONFIDENTIAL</b>		UNLESS OTHERWISE SPECIFIED DIMENSIONS ARE IN INCHES AND TOLERANCES ARE AS FOLLOWS		
THE INFORMATION CONTAINED IN THIS DRAWING IS THE SOLE PROPERTY OF BIOMICROBICS, INC.. ANY REPRODUCTION IN PART OR AS A WHOLE WITHOUT THE WRITTEN PERMISSION OF BIOMICROBICS, INC. IS PROHIBITED.		X° ± 1° .X ± .50 .XX ± .25		
<b>DO NOT SCALE DRAWING</b>		DRAWN BY: ESG		DESCRIPTION MICROFAST 0.75 UNIT WITH LID
SHEET 4 OF 6		DATE: 6/24/2022		
SCALE: 1:32		APPROVED BY: MSH		PART NUMBER
SIZE: B		APPROVED DATE: 6/24/2022		600-FINMCF0.75
				REV
				E

## FOOT MOUNT INSTALL

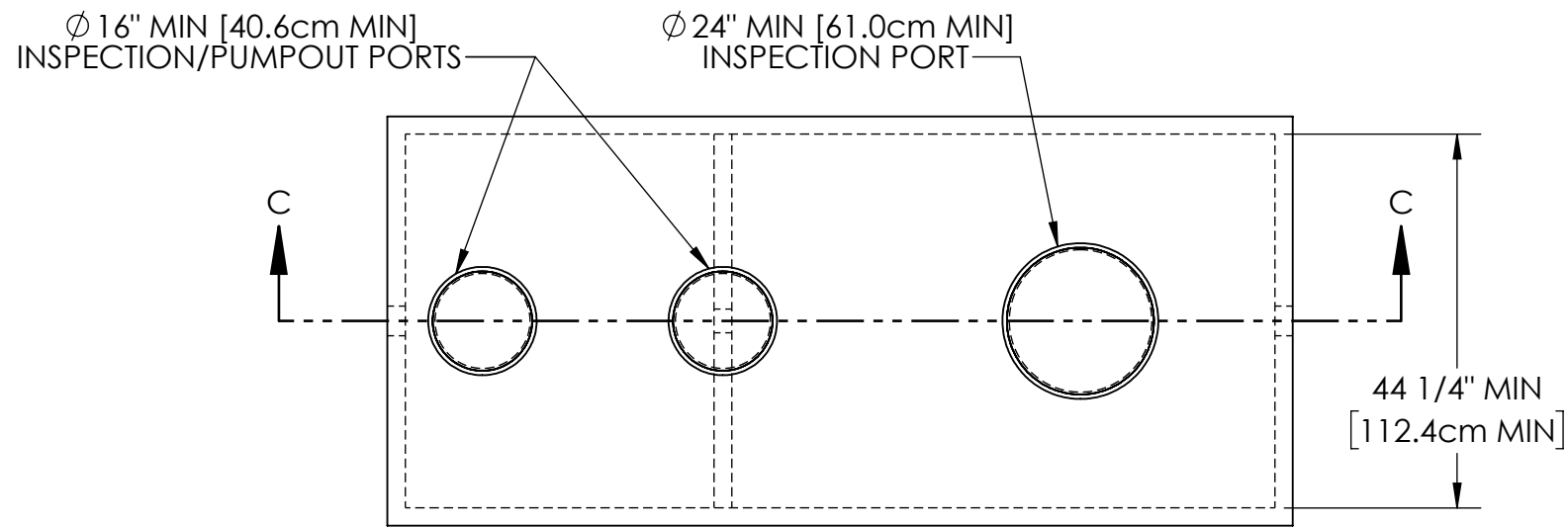

### SETTLING ZONE

375 GALLON MIN (1420 L MIN)

### TREATMENT ZONE

540 GALLON MIN (2044 L MIN)

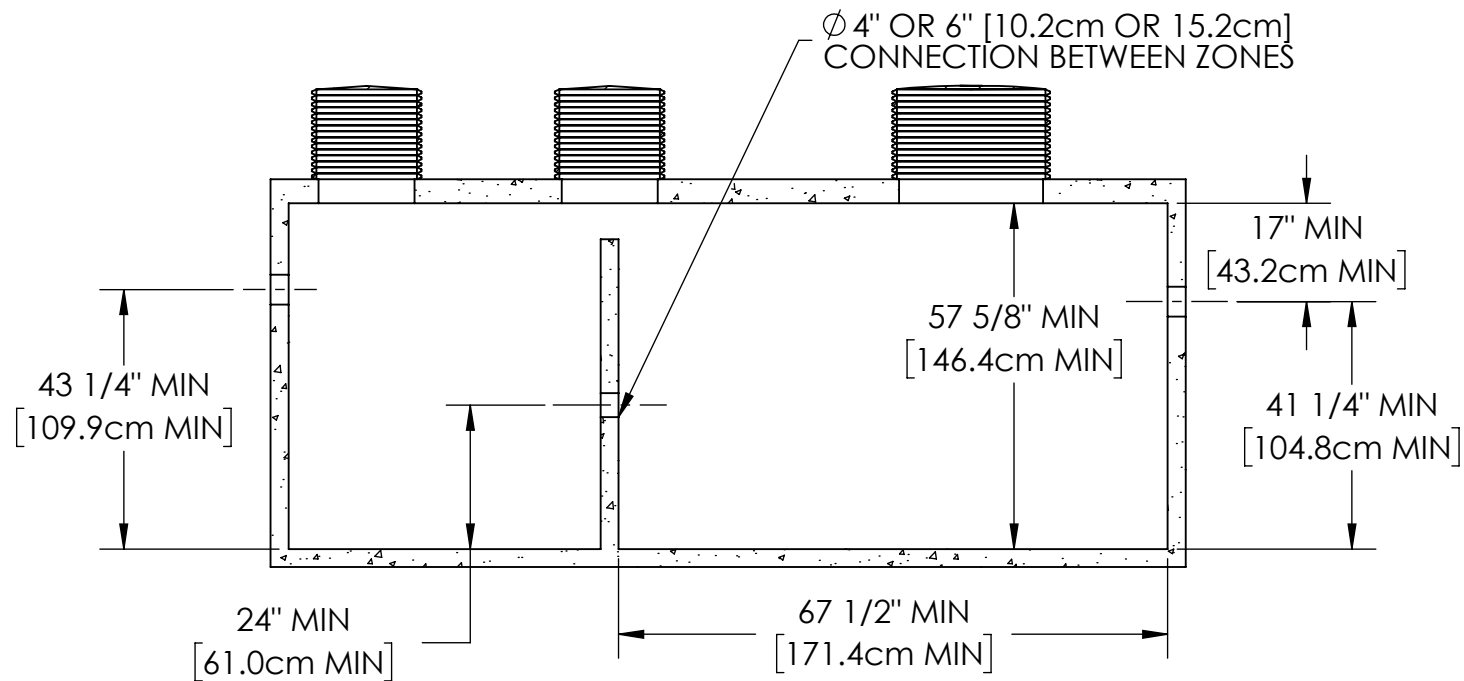

### SECTION C-C

## LID MOUNT INSTALL

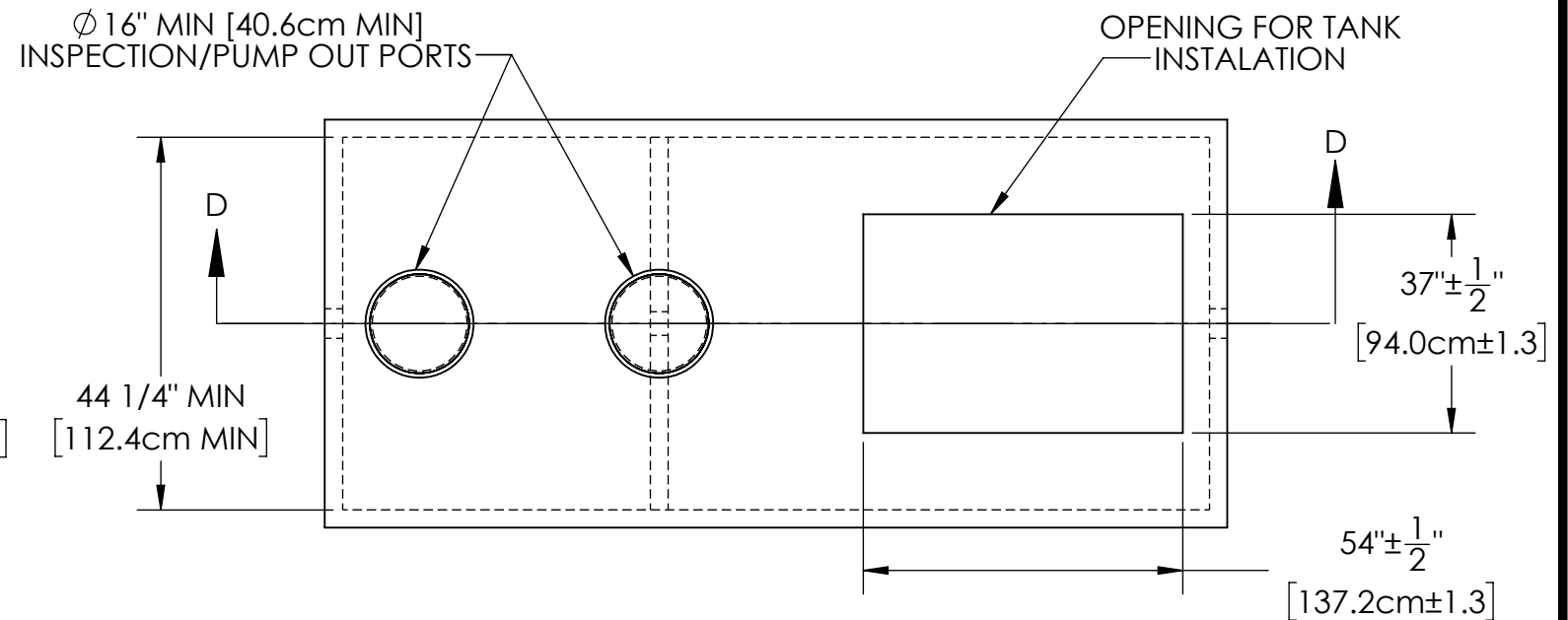

### SETTLING ZONE

375 GALLON MIN (1420 L MIN)

### TREATMENT ZONE

540 GALLON MIN (2044 L MIN)

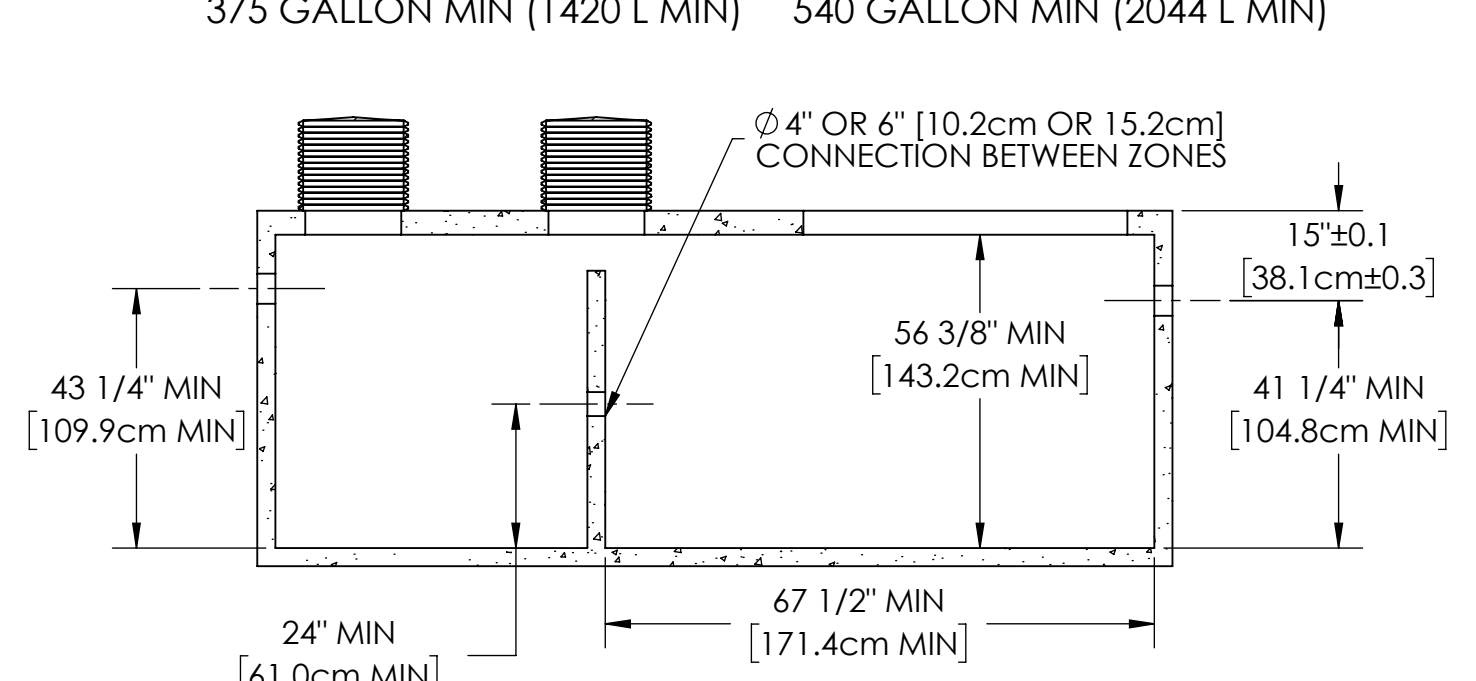

### SECTION D-D

## NOTES:

1. **MINIMUM DIMENSIONS DO NOT DETERMINE OVERALL TANK CAPACITY.**
2. INSPECTION/PUMPOUT PORT LOCATIONS MAY VARY DEPENDING ON TANK CONSTRUCTION.
3. ALL APPURTENANCES TO FAST@ (E.G. TANKS, ACCESS PORTS, ELECTRICAL, ETC.) MUST CONFORM TO ALL APPLICABLE COUNTY, STATE, PROVINCE, AND LOCAL PLUMBING AND ELECTRICAL CODES.
4. PUMP OUT ACCESS SHALL BE ADEQUATE TO THOROUGHLY CLEAN OUT BOTH ZONES.
5. IF LESS THAN THE SPECIFIED MINIMUMS ARE CONSIDERED NECESSARY, CONSULT FACTORY FOR GUIDANCE.
6. SPECIALIZED TREATMENT NEEDS MAY REQUIRE SPECIFIC FEATURES TO BE INCORPORATED INTO THE DESIGN. CONSULT FACTORY FOR GUIDANCE.
7. MINIMUM OF 2.0in [5.1cm] INVERT IS NECESSARY BETWEEN THE INLET AND OUTLET OF EACH ZONE FOR GRAVITY FLOW SYSTEMS.
8. TANK VOLUMES MAY VARY BY APPLICATION AND JURISDICTION.
9. MICROFAST UNITS CAN GO INTO OTHER THAN SHOWN TYPES OF TANKS, NON RECTANGULAR, PLASTIC, ETC.
10. TANKS OF VARYING SHAPE AND MATERIAL CAN BE USED WITHIN SPECIFIED MINIMUMS.
11. TANK SET UP MAY BE DIFFERENT THAN SHOWN, i.e., SEPARATE SETTLING AND TREATMENT TANKS.

<b>PROPRIETARY AND CONFIDENTIAL</b> THE INFORMATION CONTAINED IN THIS DRAWING IS THE SOLE PROPERTY OF BIOMICROBICS, INC.. ANY REPRODUCTION IN PART OR AS A WHOLE WITHOUT THE WRITTEN PERMISSION OF BIOMICROBICS, INC. IS PROHIBITED. <b>DO NOT SCALE DRAWING</b>		UNLESS OTHERWISE SPECIFIED DIMENSIONS ARE IN INCHES AND TOLERANCES ARE AS FOLLOWS X° ± 1° .X ± .50 .XX ± .25		 BETTER WATER. BETTER WORLD.	
		DRAWN BY: ESG			
SHEET 5 OF 6		DATE: 6/24/2022		PART NUMBER 600-FINMCF0.75	
		APPROVED BY: MSH		REV E	
SCALE: 1:32	SIZE: B	APPROVED DATE: 6/24/2022			

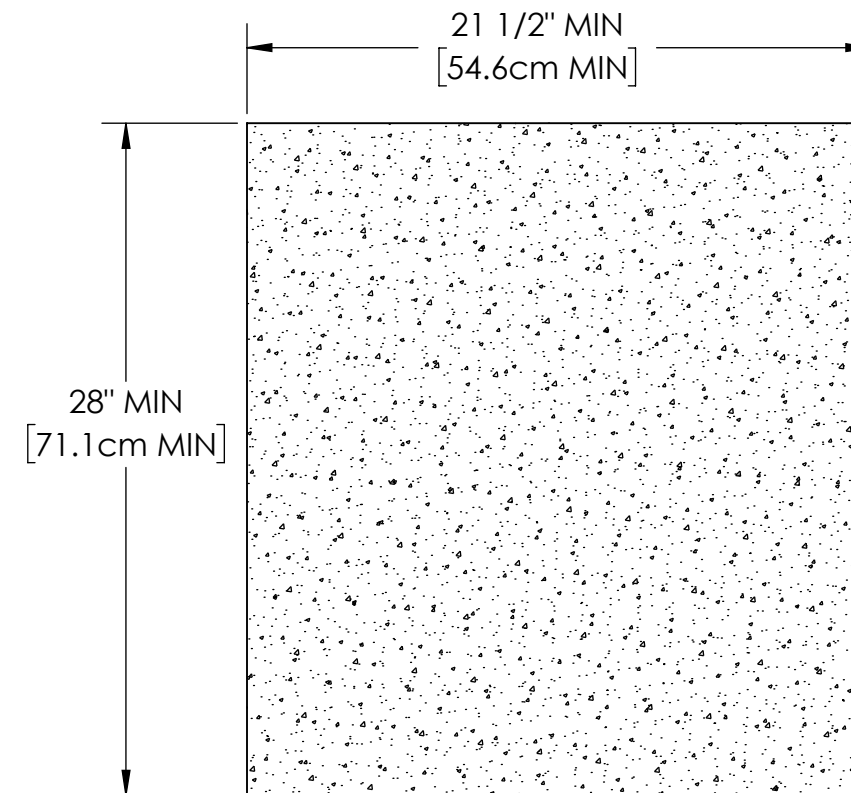
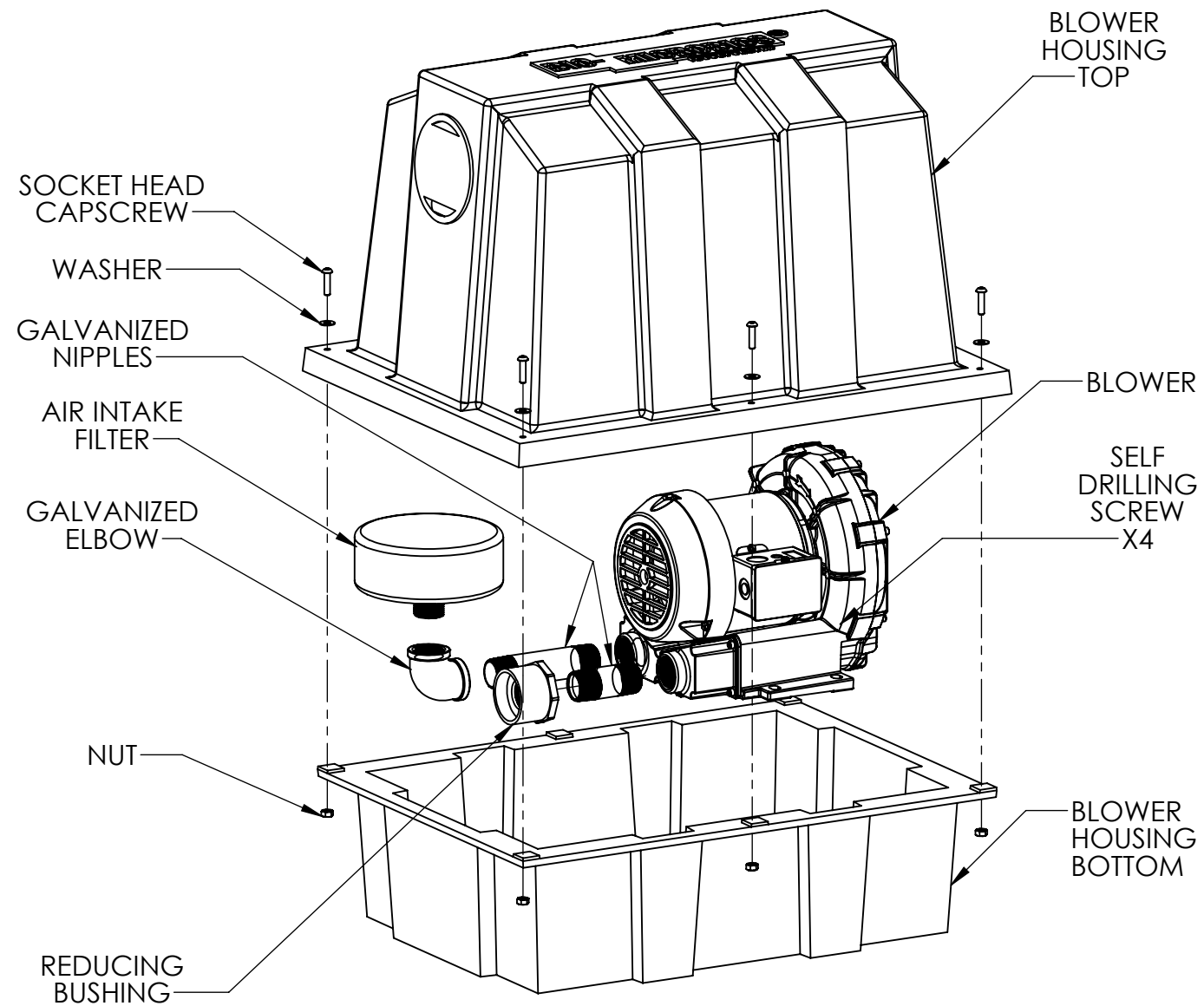

**BLOWER PAD**

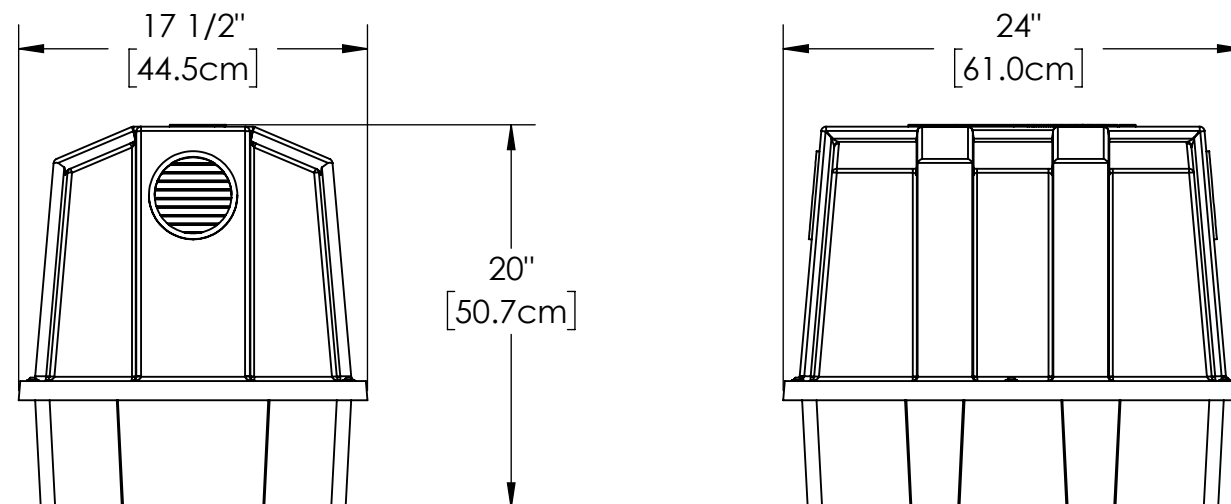

**NOTES:**

1. SOME MICROFAST CONFIGURATIONS MAY REQUIRE DIFFERENT BLOWER HOUSINGS.
2. BLOWER MUST BE LOCATED ABOVE FLOOD LEVELS.

<p><b>PROPRIETARY AND CONFIDENTIAL</b></p> <p>THE INFORMATION CONTAINED IN THIS DRAWING IS THE SOLE PROPERTY OF BIOMICROBICS, INC.. ANY REPRODUCTION IN PART OR AS A WHOLE WITHOUT THE WRITTEN PERMISSION OF BIOMICROBICS, INC. IS PROHIBITED.</p> <p><b>DO NOT SCALE DRAWING</b></p>	<p>UNLESS OTHERWISE SPECIFIED DIMENSIONS ARE IN INCHES AND TOLERANCES ARE AS FOLLOWS</p> <p>X° ±1° .X ± .50 .XX ± .25</p>	
	<p>DRAWN BY: ESG</p> <p>DATE: 6/24/2022</p>	
<p>SHEET 6 OF 6</p>	<p>APPROVED BY: MSH</p>	<p>PART NUMBER 600-FINMCF0.75</p>
<p>SCALE: N/A</p>	<p>SIZE: B</p>	<p>APPROVED DATE: 6/24/2022</p>
		<p>REV E</p>



# Submersible Effluent Pump

**MODEL 3885**

## WE Series

PROSURANCE AVAILABLE FOR RESIDENTIAL APPLICATIONS.

### APPLICATIONS

Specifically designed for the following uses:

- Homes
- Farms
- Trailer courts
- Motels
- Schools
- Hospitals
- Industry
- Effluent systems

### SPECIFICATIONS

#### Pump

- Solids handling capabilities:  $\frac{3}{4}$ " maximum.
- Discharge size: 2" NPT.
- Capacities: up to 140 GPM.
- Total heads: up to 128 feet TDH.
- Temperature: 104°F (40°C) continuous, 140°F (60°C) intermittent.
- See order numbers on reverse side for specific HP, voltage, phase and RPM's available.

### FEATURES

- **Impeller:** Cast iron, semi-open, non-clog with pump-out vanes for mechanical seal protection. Balanced for smooth operation. Silicon bronze impeller available as an option.
- **Casing:** Cast iron volute type for maximum efficiency. 2" NPT discharge.
- **Mechanical Seal:** SILICON CARBIDE VS. SILICON CARBIDE sealing faces. Stainless steel metal parts, BUNA-N elastomers.

- **Shaft:** Corrosion-resistant, stainless steel. Threaded design. Locknut on all models to guard against component damage on accidental reverse rotation.
- **Fasteners:** 300 series stainless steel.
- Capable of running dry without damage to components.
- Designed for continuous operation when fully submerged.

### MOTORS

- Fully submerged in high-grade turbine oil for lubrication and efficient heat transfer.
- Class B insulation on  $\frac{1}{3}$ - $1\frac{1}{2}$  HP models.
- Class F insulation on 2 HP models.

### Single phase (60 Hz):

- Capacitor start motors for maximum starting torque.
- Built-in overload with automatic reset.
- SJTOW or STOW severe duty oil and water resistant power cords.
- $\frac{1}{3}$  – 1 HP models have NEMA three prong grounding plugs.
- $1\frac{1}{2}$  HP and larger units have bare lead cord ends.

### Three phase (60 Hz):

- Class 10 overload protection must be provided in separately ordered starter unit.
- STOW power cords all have bare lead cord ends.

- **Designed for Continuous Operation:** Pump ratings are within the motor manufacturer's recommended working limits,

can be operated continuously without damage when fully submerged.

- **Bearings:** Upper and lower heavy duty ball bearing construction.

- **Power Cable:** Severe duty rated, oil and water resistant. Epoxy seal on motor end provides secondary moisture barrier in case of outer jacket damage and to prevent oil wicking. Standard cord is 20'. Optional lengths are available.

- **O-ring:** Assures positive sealing against contaminants and oil leakage.

### AGENCY LISTINGS



Tested to UL 778 and CSA 22.2 108 Standards By Canadian Standards Association File #LR38549

Goulds Pumps is ISO 9001 Registered.

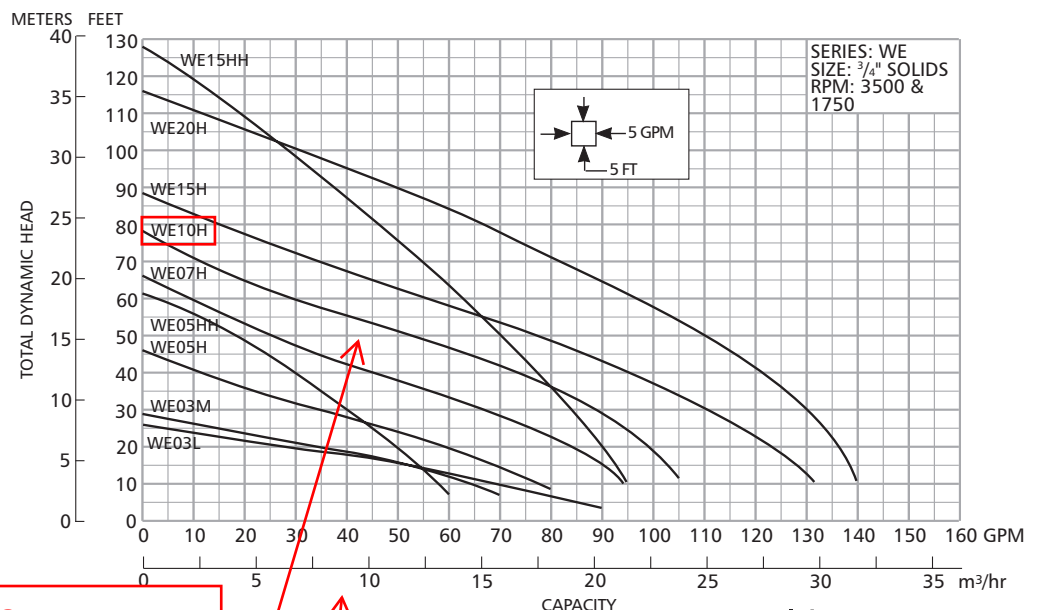

**43 GPM  
@ 48.98' TDH**

**CONTACT ENGINEER TO RE-SIZE PUMP IF TRANSMISSION LINE LENGTH EXCEEDS 600'**

Goulds Pumps



ITT Industries

**COMPONENTS**

Item No.	Description
1	Impeller
2	Casing
3	Mechanical Seal
4	Motor Shaft
5	Motor
6	Ball Bearings
7	Power Cable
8	Casing O-Ring

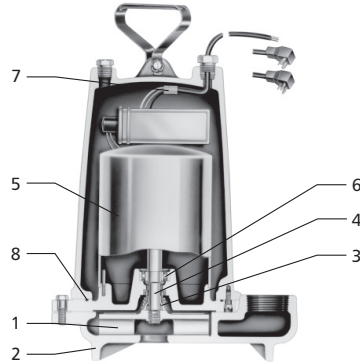

**MODELS**

Order No.	HP	Volts	Phase	Max. Amp.	RPM	Solids	Wt. (lbs.)	
WE0311L	1/3	115	1	10.7	1750	3/4"	56	
WE0318L		208						
WE0312L		230						
WE0311M		115						
WE0318M		208						
WE0312M		230						
WE0511H	1/2	115	3	14.5	3500	3/4"	60	
WE0518H		208						
WE0512H		230						
WE0538H		200						
WE0532H		230						
WE0534H		460						
WE0537H	575							
WE0511HH	1	115	1	14.5	3500	3/4"	70	
WE0518HH		208						
WE0512HH		230						
WE0538HH		200						
WE0532HH		230						
WE0534HH		460						
WE0537HH	575							
WE0718H	3/4	208	3	11.0	3500	3/4"	70	
WE0712H		230						
WE0738H		200						
WE0732H		230						
WE0734H		460						
WE0737H		575						
WE1018H	208	1	14.0					
WE1012H	230	1	12.5					
WE1038H	1	200	3	8.1	3500	3/4"	80	
WE1032H		230						
WE1034H		460						
WE1037H		575						
WE1518H		208		1				17.5
WE1512H		230						
WE1538H	200	3	10.6					
WE1532H	230							
WE1534H	460							
WE1537H	575							
WE1518HH	208		1	17.5				
WE1512HH	230							
WE1538HH	200	3	10.6					
WE1532HH	230							
WE1534HH	460							
WE1537HH	575							
WE2012H	2		230	1	18.0	3500	3/4"	83
WE2038H			200					
WE2032H		230						
WE2034H		460						
WE2037H		575						

**PERFORMANCE RATINGS** (gallons per minute)

Order No.	WE03L	WE03M	WE05H	WE07H	WE10H	WE15H	WE05HH	WE15HH	WE20H
HP	1/3	1/3	1/2	3/4	1	1 1/2	1/2	1 1/2	2
RPM	1750	1750	3500	3500	3500	3500	3500	3500	3500
5	86	-	-	-	-	-	-	-	-
10	70	63	78	94	-	-	58	95	-
15	52	52	70	90	103	128	53	93	138
20	27	35	60	83	98	123	49	90	136
25	-	-	48	76	94	117	45	87	133
30	-	-	35	67	88	110	40	83	130
35	-	-	22	57	82	103	35	80	126
40	-	-	-	45	74	95	30	77	121
45	-	-	-	35	64	86	25	74	116
50	-	-	-	25	53	77	-	70	110
55	-	-	-	-	40	67	-	66	103
60	-	-	-	-	30	56	-	63	96
65	-	-	-	-	20	45	-	58	89
70	-	-	-	-	-	35	-	55	81
75	-	-	-	-	-	25	-	51	74
80	-	-	-	-	-	-	-	47	66
90	-	-	-	-	-	-	-	37	49
100	-	-	-	-	-	-	-	28	30

**DIMENSIONS**

(All dimensions are in inches. Do not use for construction purposes.)

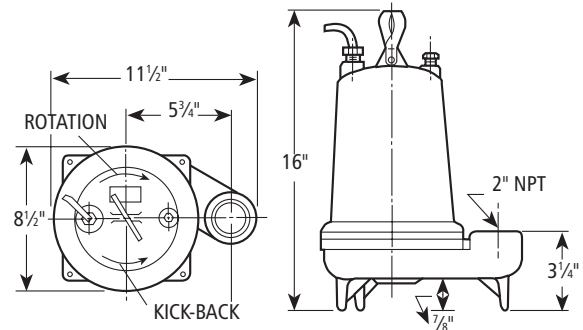

Goolds Pumps is a brand of ITT Water Technology, Inc. – a subsidiary of ITT Industries, Inc.

Goolds Pumps and the ITT Engineered Blocks Symbol are registered trademarks and tradenames of ITT Industries.

Goolds Pumps



# MODEL TD CONTROL PANEL

## Single Phase, Simplex Timed Dosing Pump Control

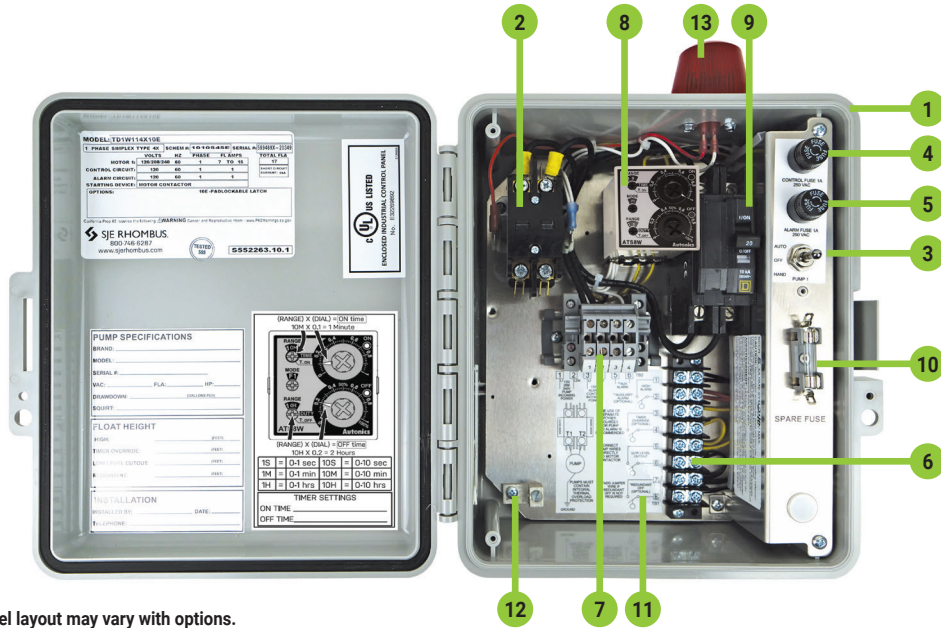

Panel layout may vary with options.

The Model TD control panel provides a reliable means of controlling one single phase pump in onsite septic installations. A programmable timer activates a magnetic motor contactor to turn the pump on and off. A low level cutout float overrides the timer to prevent the pump from running dry. An alarm float activates the audio/visual alarm system indicating a high liquid level. Common applications include sand filter systems, pressure distribution systems, mound systems, or any application requiring a timed dose. This panel is available with optional EZconnex® float connection system.

### OPTIONAL FEATURE

- 34" (86.36cm) Panel Mounting Post (Factory Installed). Includes Duplex Installation Kit (Enclosure upsized to 10" x 8" x 6" (25.4 x 20.32 x 15.24 cm). Max. Enclosure size 14" x 12" x 6" (35.56 x 30.48 x 15.24 cm)

### COMPONENTS

1. Enclosure measures 10 x 8 x 4 inches (25.40 x 20.32 x 10.16 cm); NEMA 4X (ultraviolet stabilized thermoplastic with removable mounting feet for outdoor or indoor use)
2. Magnetic motor contactor controls pump by switching electrical lines
3. HOA switch for manual pump control
4. Control fuse
5. Alarm fuse
6. Float switch terminal block
7. Incoming power terminal block
8. Programmable timer with separate variable controls allows for setting the on and off times from .1 seconds to 10 hours
9. Circuit breaker provides pump disconnect and branch circuit protection
10. Spare fuse
11. Backplate label includes diagram of float, pump, and power connections
12. Ground lug
13. Red LED beacon provides 360° visual check of alarm condition
14. Alarm horn provides audio warning of alarm condition (83 to 85 decibel rating) (Not shown)
15. Exterior alarm Test/Normal/Silence switch allows horn and light to be tested and horn to be silenced in an alarm condition; alarm automatically resets once alarm condition is cleared (Not shown)
16. Horn silence relay (No shown - mounted under bracket)

**Note: Other options available.**

**Note:** Timer Installation Label and Pump/Float Switch Installation Specification Label are located inside the panel on enclosure cover.



**MODEL TD - Single phase, simplex timed dosing pump control.**

<b>TD</b> CONTROL PANEL	<b>ALARM PACKAGE</b>	<b>W</b> ENCLOSURE RATING	<b>STARTING DEVICE</b>	<b>PUMP FULL LOAD AMPS</b>	<b>4</b> PUMP DISCONNECTS	<b>FLOAT SWITCH APPLICATION</b>	<b>OPTIONS (LISTED BELOW)</b>
----------------------------	----------------------	------------------------------	------------------------	----------------------------	------------------------------	---------------------------------	-------------------------------

<b>CONTROL PANEL</b>	✓	TD	Single Phase Simplex Timed Dosing	\$1,041.00
<b>ALARM PACKAGE</b>		0	Select Options (select Option 1F below)	- \$21.00
		1	Alarm Package (includes test/normal/silence switch, red light, & horn)	Base
<b>ENCLOSURE RATING</b>	✓	W	Weatherproof, NEMA 4X (engineered thermoplastic)	Base
<b>STARTING DEVICE</b>		1	Magnetic Motor Contactor 120/208/240V	\$66.00
		9	Magnetic Motor Contactor 120V only	Base
<b>PUMP FULL LOAD AMPS</b>		0	0 - 7 FLA	Base
		1	7 - 15 FLA	Base
		2	15 - 20 FLA	Base
<b>PUMP DISCONNECTS</b>	✓	4	Circuit Breaker	Base
<b>FLOAT SWITCH APPLICATION</b>		H	Pump Down - 20' Low Level Cutout (select Option 17 or 21 below)	Base
		E	EZconnex® Float Switch System (select Option 33, 35 or 36 below)	- \$64.00
		X	No Floats	- \$64.00

<b>PRICING WORKSHEET</b>	<b>Model TD Base Price</b>	<b>\$1,041.00</b>
	Alarm Package	_____
	Enclosure Rating	_____
	Starting Device	_____
	Pump Full Load Amps	_____
	Float Switch Application	_____
	Total Options	_____
	<b>TOTAL LIST PRICE</b>	_____

OPTIONS	DESCRIPTION	LIST PRICE
1F	Door Mounted Alarm Indicator with Horn and Test/Normal/Silence Switch (must select "0" for <b>ALARM PACKAGE</b> )	\$33.00
4B	Red Redundant Off Indicator & Alarm (must also select Option 4D if floats are required)	\$60.00
4D	Redundant Off Float	\$28.00
4E	Redundant Off Float, Alarm Activation (20' SJE PumpMaster® SPDT)	\$43.00
6A	Auxiliary Alarm Contact, Form A	\$43.00
8A	Elapsed Time Meter	\$60.00
8C	Event (Cycle) Counter	\$60.00
10E	Lockable Latch	\$22.00
10K	Anti-condensation Heater	\$109.00
10P	Panel Mounting Post - Factory Installed, Includes Duplex Installation Kit (Enclosure Upsized to 10x8x6, Max 14x12x6)	\$155.00

OPTIONS	DESCRIPTION	LIST PRICE
16A	10' Cord in Lieu of 20' Cord (per float)	-\$3.00
16B	15' Cord in Lieu of 20' Cord (per float)	-\$2.00
16C	30' Cord in Lieu of 20' Cord (per float)	\$5.00
16D	40' Cord in Lieu of 20' Cord (per float)	\$15.00
17E	Sensor Float® Mini - Redundant Off, High Level Alarm (per Float) - Mercury	\$4.00
18A	Timer Override Float (20' SJE PumpMaster®) - Mechanical	\$43.00
19X	Door Mounted Pump Run Indicator	\$33.00
21E	SJE PumpMaster® - Redundant Off, High Level Alarm (per float) - Mechanical	\$4.00
33U	EZconnex® 3-Port, 50', with 10' Floats (3) / Pipe Clamp	\$313.00
35U	EZconnex® 4-Port, 50', with 10' Floats (4) / Pipe Clamp	\$437.00
36U	EZconnex® 3-Port, 50', with 10' Floats (2) / Pipe Clamp, Sealing Plug	\$276.00

## ***GENERAL NOTES***

1. The contractor during inspection of the system shall perform pressure settings of lateral operating pressures. The contractor shall make available enough pressure measuring devices so that numerous simultaneous pressure determinations may be made as requested by the engineer.

## ***TIMERS***

1. Timer to operate in such a manner as to allow a minimum of six hours off time between doses and to equalize doses throughout the day. Run time will be set at: 290 seconds. Off time at 8 hours, 3 doses per day.
2. Static head will be field measured. Orifice head will be measured with a standpipe on the furthest lateral.
3. Timer to SJ Rhombus TD-1 or a timer of equal performance as approved by the engineer.
4. Timer is to have a battery back up power source.
5. The timer shall be installed in such a manner to override the float switches.

## ***GENERAL AND CONSTRUCTION NOTES TO INSTALLER***

1. The Contractor shall field verify all existing conditions and features prior to construction. All Piping and Fittings shall be *Pressure rated schedule 40 PVC*. No substitutes will be permitted unless noted on the approved plans or approved by the designer prior to construction.
2. The Contractor shall field verify all isolation distances prior to initiating construction of system. If discrepancies are found in the field, the Contractor shall immediately contact the designer at the above number.
3. Any changes in the specified/approved equipment, i.e. pumps, alarms, timers, etc., shall be approved by the designer prior to construction.
4. No System shall be installed during inclement conditions, i.e. rain, snow, saturated conditions, frozen conditions, or any other condition that would create compaction, smearing or destruction of the soil structure in the disposal area.
5. The designer is not responsible for the placement of the dwelling or the actual location of the property lines shown on the approved site plan as no perimeter survey was provided or performed by the designer (unless specified on the design drawings).

6. All Low Pressure Pipe (LPP) disposal systems must be installed with a trencher. ***NO LPP SYSTEM WILL BE INSPECTED OR APPROVED BY THE DESIGNER IF INSTALLED WITH A BACKHOE.***
7. Any changes made to the location of the approved system must have a pre-construction as-built done and approved by The Division of Water Resources at the expense of the contractor. No change shall be made unless approved by the designer and The Division of Water Resources. Any change made to the approved permit without the prior approval of the designer or the Division of Water Resources shall be the responsibility of the Contractor.
8. All systems requiring a pump shall be pressure tested by the designer and the Contractor during the final inspection. Any equipment necessary for providing this service, i.e. generator, hoses, water, pressure gauges shall be provided by the Contractor.
9. The Contractor or his/her representative shall be present during the final inspection. The Contractor shall notify the designer 48 hours in advance to schedule the final inspection.
10. The designer will complete only one site visit for final inspection. Any additional site visits required for designer approval will be billed as an extra to the Contractor and shall be paid prior to initiating the inspection report.
11. The system shall be installed based on the approved permit and the regulations and memorandums set forth by the Department of Natural Resources and Environmental Control, Division of Water Resources.

## ***GENERAL NOTES TO PROPERTY OWNERS***

1. Unless otherwise stated in the Department of Natural Resources and Environmental Control (DNREC), Division of Water Resources regulations, all septic tanks shall be pumped every three (3) years. At the time of pumping, the tank shall be inspected for any deficiencies such as: concrete deterioration, cracks, holes, leaking, etc. The baffles should be inspected for cracks, concrete deterioration, etc.
2. If a filtering devise has been installed, i.e. Zabel, Webby Bucket, etc., at the time of cleanout and/or per the manufacturers specifications, the device should be rinsed thoroughly into the septic tank with a garden hose and reinstalled. This should be done so that accumulated debris can be pumped out while the waste hauler is there.
3. Be absolutely sure that your septic tank stays in good operating condition. Never allow sludge or scum to escape from the septic tank. It will clog your drain tiles and cause the drain field to fail.
4. Keep automobiles and all heavy vehicles and equipment off the field and tanks.
5. Do not allow stormwater ponding to collect over the field.
6. Do not allow downspouts to drain onto or into your drain field or tanks.
7. Do not stockpile snow or soil on the drain field and tanks.

8. Dense grass cover and other shallow rooted plants are beneficial over a drain field. Think ahead when planting trees and shrubs. Although they promote moisture removal from the drain field, their roots may clog the drain tiles. Check with The DNREC for vegetation that will be helpful to the system.
9. Mark the boundaries of your system as a reminder.
10. Do not use chemicals to clean or sweeten your system except on the advice of the DNREC.
11. Do not use a kitchen garbage disposal.
12. Do not place harmful materials in the tanks. Avoid fats, solvents, oils, disinfectants, paints, chemicals, poisons, coffee grounds, paper towels, disposable diapers, sanitary napkins, tampons and condoms.
13. Inspect for scum and sludge depth once each year.
14. Limit water entering your tanks.
15. Use water-saving fixtures, i.e. faucets, showers, toilets, etc. as required by the local building code.
16. Do not connect basement sump pump to the tanks.
17. Always drain appliances one at a time.
18. Spread clothes washing over the entire week and avoid half-loads.
19. Always fix faucet and toilet valve leaks.

**FAILURE TO FOLLOW THESE REQUIREMENTS AND THE REQUIREMENTS SET FORTH BY THE DNREC, DIVISION OF WATER RESOURCES, WILL RESULT IN A REDUCED LIFE SPAN OF THE SEPTIC SYSTEM, AND INCREASE THE LIKELYHOOD OF FAILURE.**