

Standard Detail & Specifications

Reinforced Silt Fence

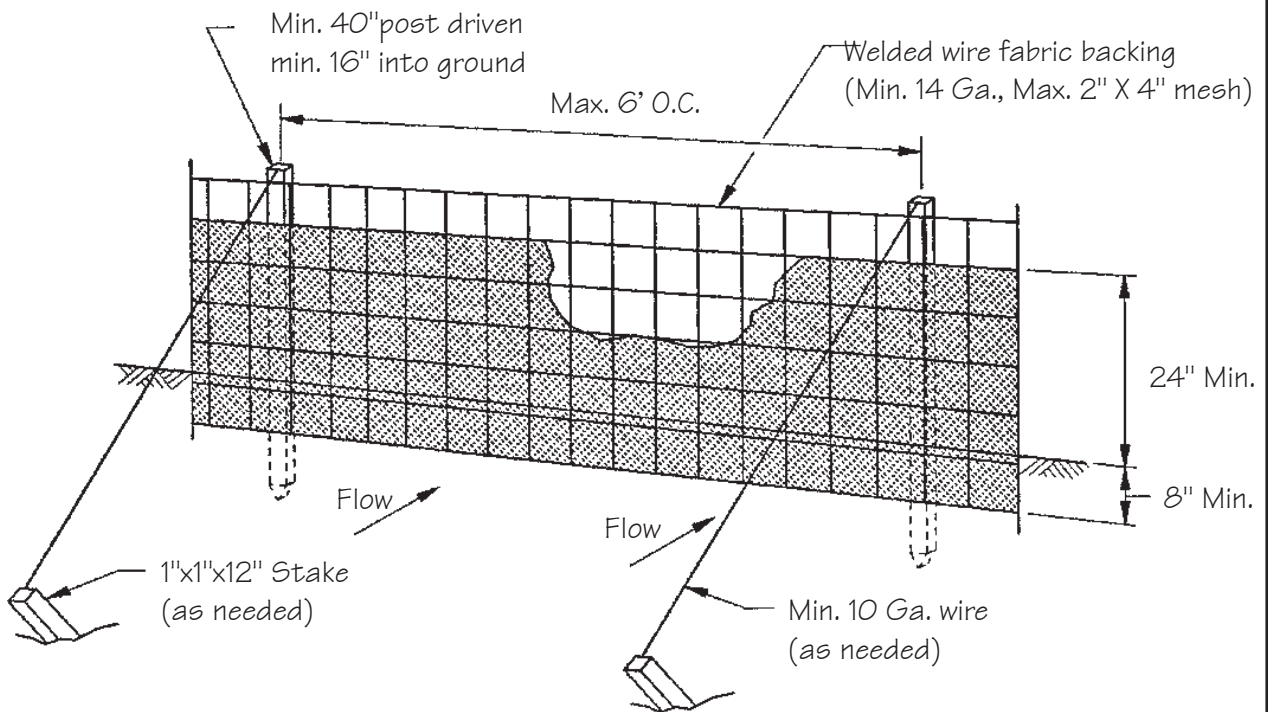

DATA
Max. controlled slope

Perspective

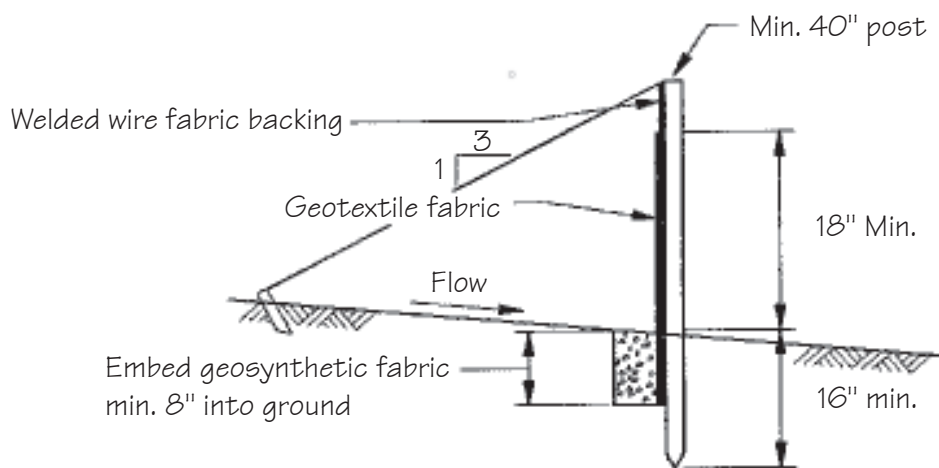

Cross-section

<p>Source:</p> <p>Adapted from Transco, Inc.</p>	<p>Symbol:</p> <p style="text-align: center;">———— RSF ————</p>	<p>Detail No.</p> <p style="text-align: center;">DE-ESC-3.1.2.2 Sheet 1 of 2 Effective July 2023</p>
--	--	---

Standard Detail & Specifications

Reinforced Silt Fence

Construction Notes:

1. Welded wire fabric to be fastened securely to the fence posts with wire ties or staples.
2. Filter cloth to be fastened securely to woven wire fence with ties spaced every 24 inches at top and mid-section.
3. When two sections of fabric adjoin each other, they shall be overlapped by six inches and folded.
4. Maintenance shall be performed as needed and material removed when "bulges" develop in the silt fence.

Materials:

1. Posts: Steel either T or U or 2" x 2" hardwood
2. Geotextile Fabric: Type GD-I
3. Backing: Woven welded wire, 14 Ga., 2" X 4" mesh opening

Source: Adapted from Transco, Inc.	Symbol: ————— RSF —————	Detail No. DE-ESC-3.1.2.2 Sheet 2 of 2 Effective July 2023
--	---------------------------------------	--