

Standard Detail & Specifications

Turbidity Curtain

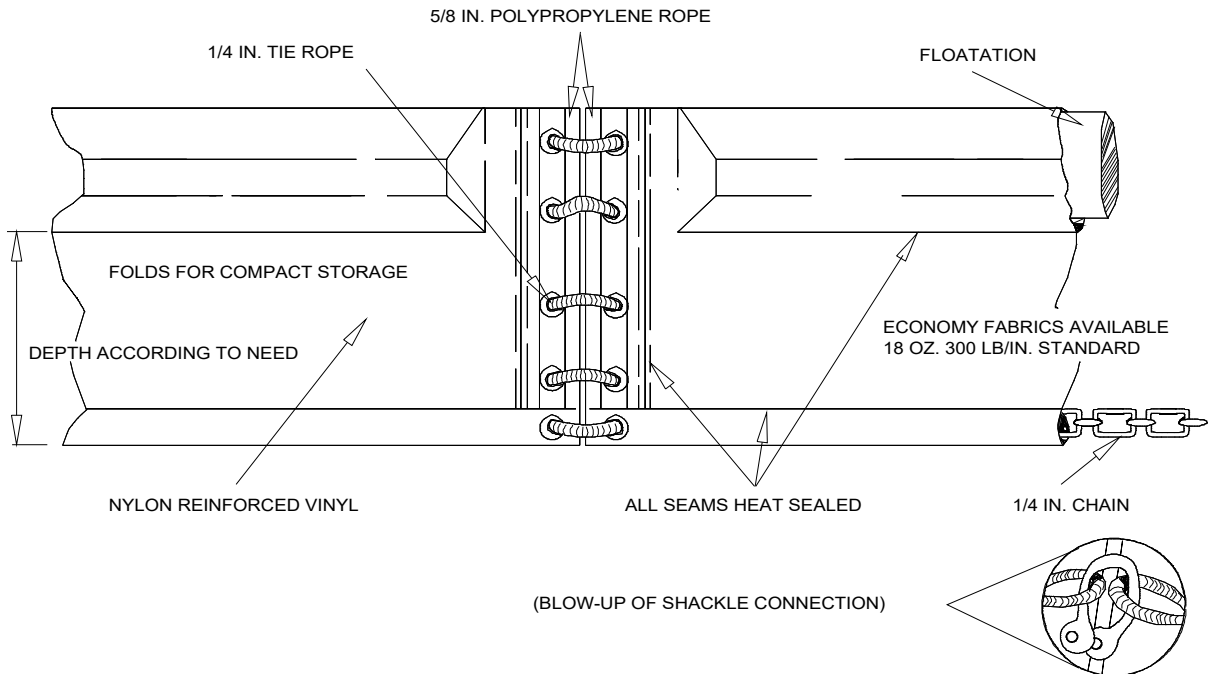

Typical Section - Type 1

DATA

Curtain type (1,2, or 3)
Layout (Std. or Alt.)

Source:

Adapt. from Amer. Boom and
Barrier Corp.

Symbol:

TC-(1/2/3)
(Std/Alt)

Detail No.

DE-ESC-3.5.3

Sheet 1 of 8

Effective July 2023

Standard Detail & Specifications

Turbidity Curtain

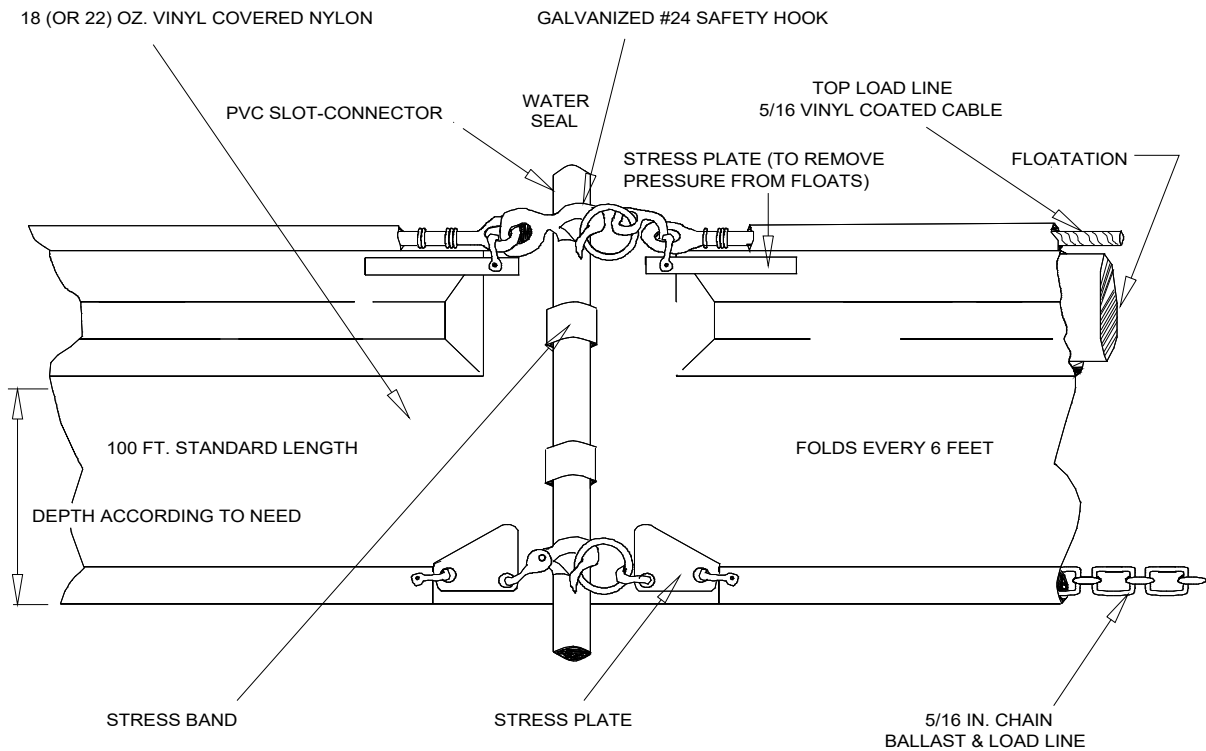

Typical Section - Type 2

DATA

Curtain type (1, 2, or 3)
Layout (Std. or Alt.)

Source:

Adapt. from Amer. Boom and
Barrier Corp.

Symbol:

TC-(1/2/3)
(Std/Alt)

Detail No.

DE-ESC-3.5.3

Sheet 2 of 8

Effective July 2023

Standard Detail & Specifications

Turbidity Curtain

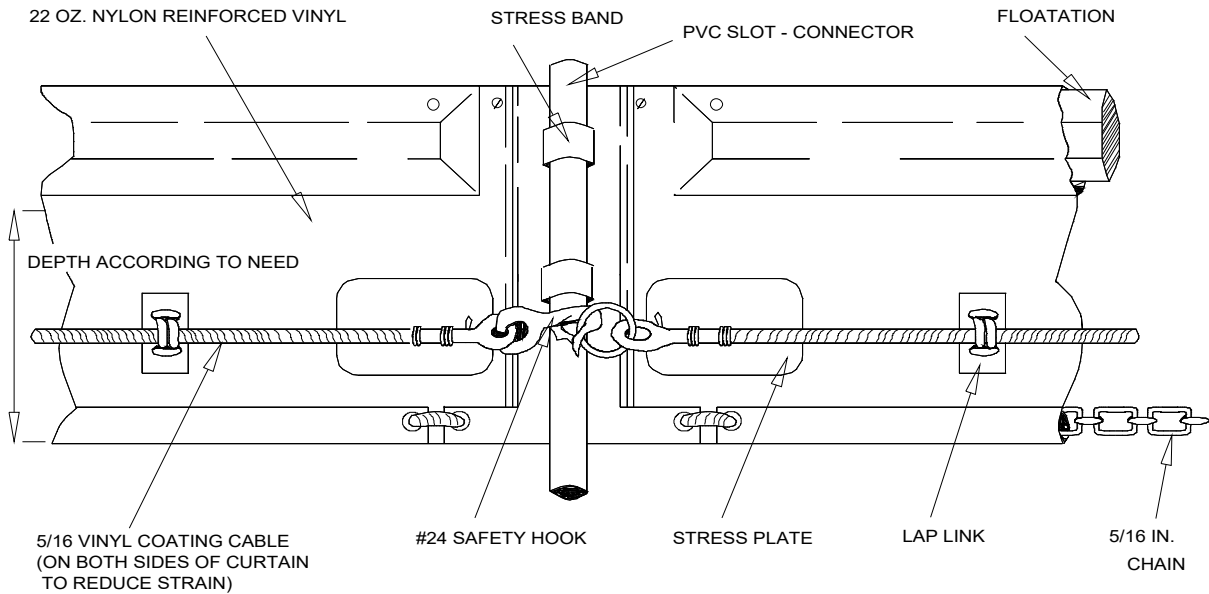

Typical Section - Type 3

DATA

Curtain type (1, 2, or 3)
Layout (Std. or Alt.)

Source:

Adapt. from Amer. Boom and
Barrier Corp.

Symbol:

— **TC-(1/2/3)** —
(Std/Alt)

Detail No.

DE-ESC-3.5.3

Sheet 3 of 8

Effective July 2023

Standard Detail & Specifications

Turbidity Curtain

NOTE: The standard layout shown is intended for use in streams, ponds and other non-tidal waters

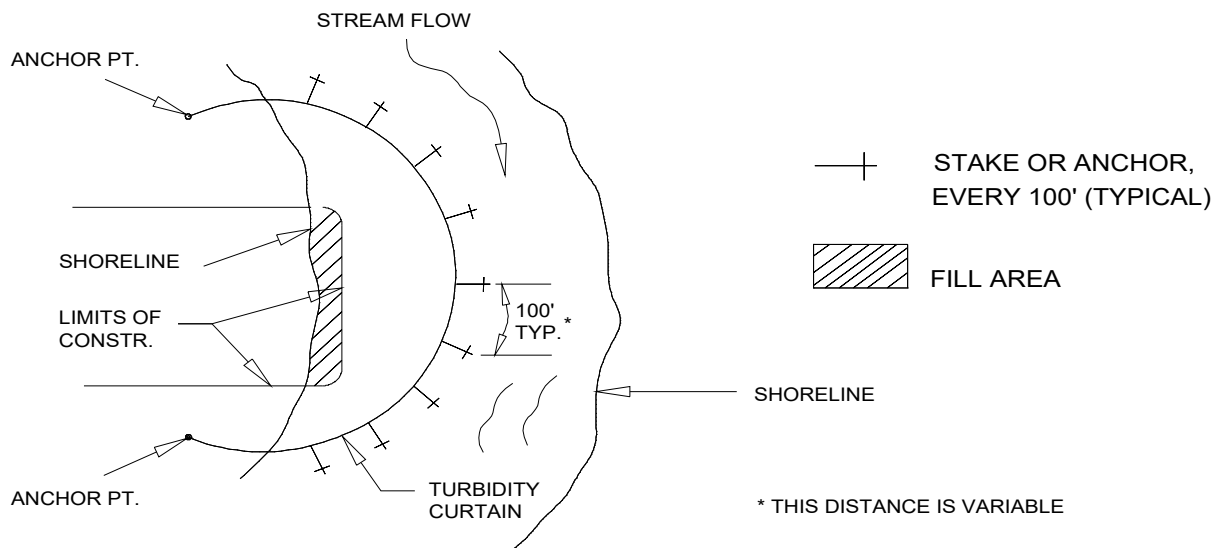

Plan - Std. Layout

<p>Source: Adapt. from Amer. Boom and Barrier Corp.</p>	<p>Symbol: TC-(1/2/3) (Std/Alt)</p>	<p>Detail No. DE-ESC-3.5.3 Sheet 4 of 8 Effective July 2023</p>
---	---	--

Standard Detail & Specifications

Turbidity Curtain

NOTE: The alternative layout shown is intended for tidal waters and/or heavy wind and wave action

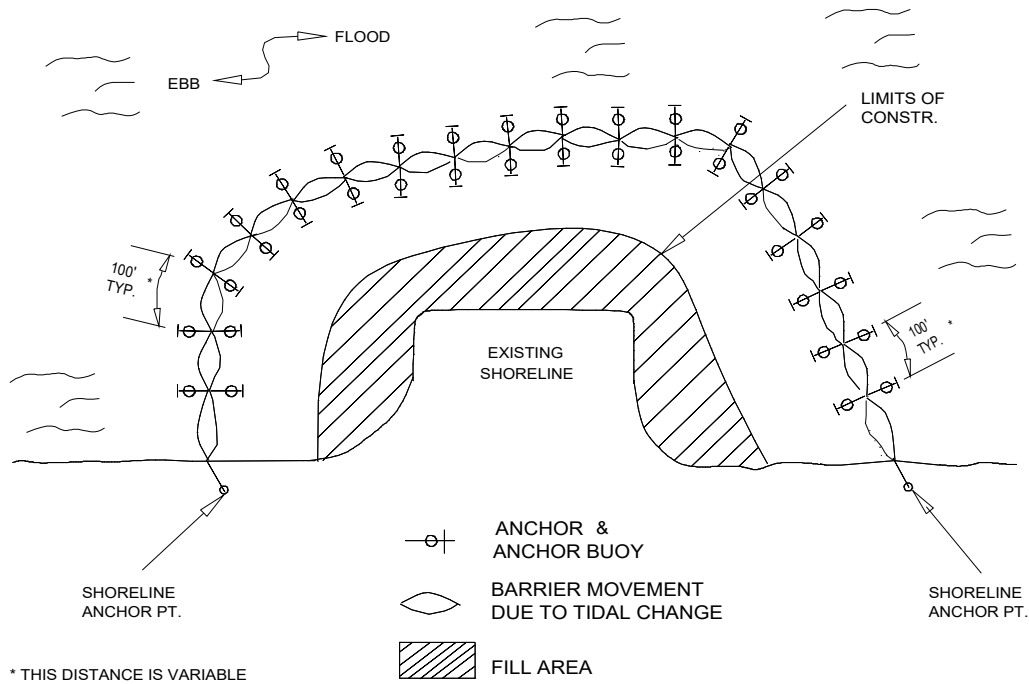

Plan - Alt. Layout

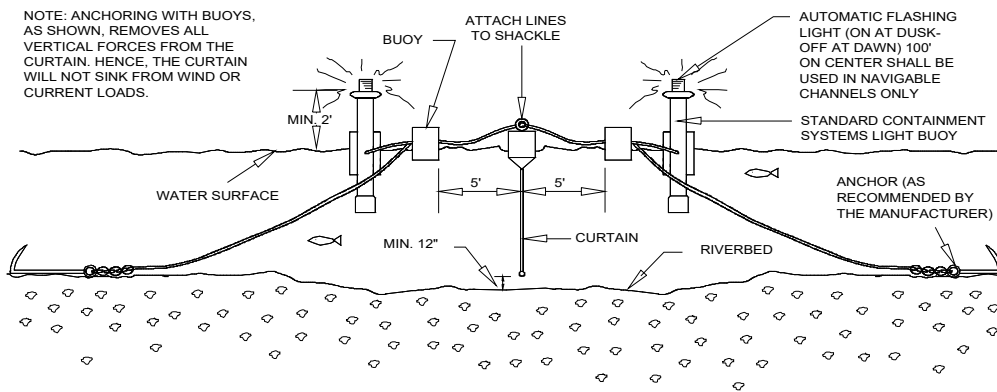

Additional Requirements for Navigable Waters

<p>Source: Adapt. from Amer. Boom and Barrier Corp.</p>	<p>Symbol: TC-(1/2/3) (Std/Alt)</p>	<p>Detail No. DE-ESC-3.5.3 Sheet 5 of 8 Effective July 2023</p>
---	--	--

Standard Detail & Specifications

Turbidity Curtain

Construction Notes:

1. Materials

- a. Barriers should be a bright color (yellow or "international" orange are recommended) that will attract the attention of nearby boaters.
- b. The curtain fabric shall meet manufacturer's recommendations for the application.
- c. Seams in the fabric shall be either vulcanized welded or sewn and shall develop the full strength of the fabric.
- d. Floatation devices shall be flexible, buoyant units contained in an individual floatation sleeve or collar attached to the curtain. Buoyancy provided by the floatation units shall be sufficient to support the weight of the curtain and maintain a freeboard of at least 3 inches above the water surface level.
- e. Load lines must be fabricated into the bottom of all floating turbidity curtains. Type II and Type III must have load lines also fabricated into the top of the fabric. The top load line shall consist of woven webbing or vinyl-sheathed steel cable and shall have a break strength in excess of 10,000 pounds. The supplemental (bottom) load line shall consist of a chain incorporated into the bottom hem of the curtain of sufficient weight to serve as ballast to hold the curtain in a vertical position. Additional anchorage shall be provided as necessary. The load lines shall have suitable connecting devices which develop the full breaking strength for connection to load lines in adjacent sections as shown in the detail.
- f. External anchors may consist of wooden or metal stakes (2- x 4-inch or 2-1/2-inch minimum diameter wood or 1.33 lbs/linear foot steel) when Type I installation is used; when Type II or Type III installations are used, bottom anchors should be used.
- g. Bottom anchors must be sufficient to hold the curtain in the same position relative to the bottom of the watercourse without interfering with the action of the curtain. The anchor may dig into the bottom (grappling hook, plow or fluke-type) or may be weighted (mushroom type) and should be attached to a floating anchor buoy via an anchor line. The anchor line should then run from the buoy to the to load line of the curtain. When used with Type III installations, these lines must contain enough slack to allow the buoy and curtain to float freely with tidal changes without pulling the buoy or curtain down and must be checked regularly to make sure they do not become entangled with debris. As previously noted, anchor spacing will vary with current velocity and potential wind and wave action; manufacturer's recommendations should be followed. See detail for orientation of external anchors and anchor buoys for tidal installations.

Source: Adapt. from Amer. Boom and Barrier Corp.	Symbol: TC-(1/2/3) (Std/Alt)	Detail No. DE-ESC-3.5.3 Sheet 6 of 8 Effective July 2023
--	--	--

Standard Detail & Specifications

Turbidity Curtain

Construction Notes (cont.)

2. Installation

- a. In the calm water of lakes or ponds (Type I installation) it is usually sufficient to set the curtain end stakes or anchor points (using anchor buoys if bottom anchors are employed), then tow the curtain in the furled condition out and attach it to the stakes or anchor points. Following this, any additional stakes or buoyed anchors required to maintain the desired location of the curtain may be set and these anchor points made fast to the curtain. Only then shall the furling lines be cut to allow the curtain skirt to drop.
- b. In rivers or in other moving waters (Type II and Type III installations) it is important to set all curtain anchor points. Care must be taken to ensure that anchor points are of sufficient holding power to retain the curtain under the existing current conditions, prior to putting the furled curtain into the water. Anchor buoys should be employed on all anchors to prevent the current from submerging the flotation at the anchor points. If the curtain is being installed into tidal areas which would be subject to currents in both directions, anchors should be provided on both sides of the curtain. This will minimize curtain movement and prevent the curtain from overrunning the anchors during tide reversals. After the anchors have been secured, the furled curtain should be secured to the upstream anchor point and then sequentially attached to each next downstream anchor point until the entire curtain is in position. Before unfurling, the "lay" of the curtain should be assessed and any necessary adjustments made to the anchors. Once the location has been deemed adequate, the furling lines may be cut to allow the skirt to drop.
- c. Anchor lines should be attached to the flotation device, not to the bottom of the curtain. The anchoring line attached to the flotation device on the downstream side will provide support for the curtain. Attaching the anchors to the bottom of the curtain could cause premature failure of the curtain due to the stresses imparted on the middle section of the curtain.
- d. Turbidity curtain shall not be installed across channel flows unless there is a danger of causing sediment deposition to occur in the middle of a watercourse, thereby blocking access or creating a sand bar. In such situations, the curtain may be installed so as to form a long-sided, sharp "V" to deflect clean water around a work site, confining most of the silt-laden water to the work area inside the "V" and directing it to the shoreline. In no case shall the curtain be installed perpendicular to the channel flow.

Source:

Adapt. from Amer. Boom and
Barrier Corp.

Symbol:

—— **TC-(1/2/3)** ——
(Std/Alt)

Detail No.

DE-ESC-3.5.3

Sheet 7 of 8

Effective July 2023

Standard Detail & Specifications

Turbidity Curtain

Construction Notes (cont.)

3. Maintenance

- a. The individual(s) identified on the plan as responsible for maintenance of the curtain shall do so for the duration of the project in order to ensure the continuous protection of the watercourse.
- b. Should repairs to the geotextile fabric become necessary, repair kits are generally available from the manufacturer. The manufacturer's instructions must be followed to ensure the adequacy of the repair.
- c. When the curtain is no longer required as determined by the inspector, the curtain and related components shall be removed in such a manner as to minimize turbidity. Remaining sediment shall be sufficiently settled before removing the curtain. Sediment may be removed and the original depth (or plan elevation) restored. Any spoils must be taken to an approved upland disposal area and stabilized in accordance with the approved plan.

4. Removal

- a. Care shall be taken to protect the skirt from damage as the turbidity curtain is dragged from the watercourse.
- b. The site selected to bring the curtain ashore should be free of sharp rocks, broken cement, debris, etc. so as to minimize damage when hauling the curtain over the area.
- c. If the curtain has a deep skirt, it can be further protected by running a small boat along its length with a crew installing furling lines before attempting to remove the curtain from the water.

Source: Adapt. from Amer. Boom and Barrier Corp.	Symbol: TC-(1/2/3) (Std/Alt)	Detail No. DE-ESC-3.5.3 Sheet 8 of 8 Effective July 2023
--	--	--